

# PM300

## 300 mm Manual Probe System

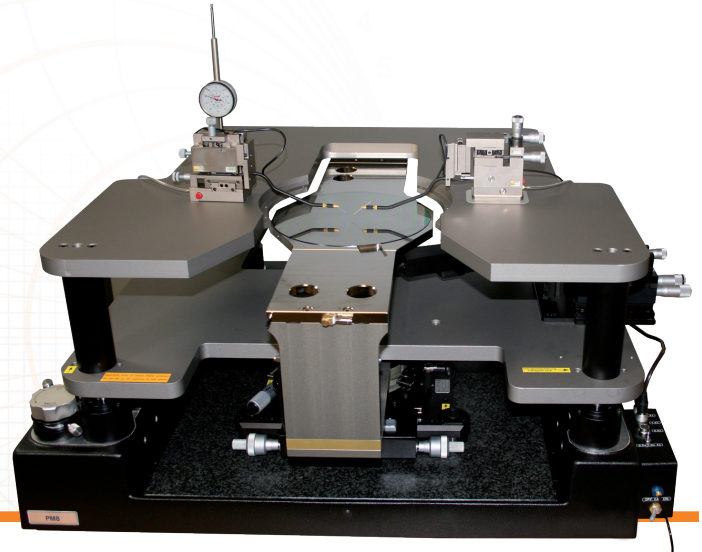

### DATA SHEET

The PM300 probe system is the ideal solution for engineering tests of 300 mm wafers and substrates. Whatever your application, the versatility of the PM300 meets all requirements from failure analysis (FA) to device and wafer characterization (DWC) to wafer-level reliability (WLR) testing and always ensures the highest accuracy. With the optional square chuck, the PM300 can be also used for testing of flat panel displays.

The superior mechanics of the probe system are the basis for stable and precise system setup regardless of your application. The X and Y axes of the chuck stage can be moved easily and individually for fast coarse adjustment. Each axis has been designed with an individual magnetic lock and a vacuum brake that enables the fine glide chuck stage to be exactly positioned whenever you release the button. Fine adjustment is ensured for X and Y by high-precision micrometers.

The PM300 has been designed with the user in mind. You can start out with the basic setup of the PM300 and the system is scalable to meet your expanding test requirements. For example, light-sensitive measurements in a ShieldEnclosure™, thermal chucks or various high-frequency test setups up to mmW are available. Further flexibility is achievable with motorized probe positioners.

### FEATURES / BENEFITS

Flexibility	<ul style="list-style-type: none"><li>Flexible design for engineering tests</li><li>Easy changeover between different applications</li><li>Ideal for failure analysis, DWC and WLR applications</li><li>Wide range of accessories available, for example ShieldEnclosure SE1200</li><li>Thermal chucks (only hot) and motorized microscope available</li></ul>
Stability	<ul style="list-style-type: none"><li>Superior mechanics for highest degree of stability</li></ul>
Ease of use	<ul style="list-style-type: none"><li>Quick and easy system set up</li><li>Independent, coarse movement of X and Y axes</li><li>Easy fine adjustments through high-precision micrometers located on frontside of chuck stage</li><li>Independent magnetic locks and vacuum brakes for X and Y axes</li><li>Ergonomic low-profile design</li></ul>

## SPECIFICATIONS\*

### Chuck Stage

Range of movement	X, Y, theta
Coarse adjustment	300 mm x 300 mm
Fine adjustment	10 mm x 10 mm (63.5 tpi)
Planarity of granite slab over entire range of movement	$< \pm 2.5 \mu\text{m}$
Load stroke	10 mm
Theta travel	$\pm 8^\circ$

### Chuck

Diameter	300 mm (optional square)
Planarity	$8 \mu\text{m}$

### Probe Platen

Z travel	40 mm
Contact / Separation stroke	0.4 mm
Utilities	
Power	115 / 230 V, 50 / 60 Hz
Vacuum	- 0.8 bar
Compressed air	6 to 10 bar

\*Data, design and specification depend on individual process conditions and can vary according to equipment configurations.  
Not all specifications may be valid simultaneously.

## PHYSICAL DIMENSIONS

Weight 270 kg (depending on number of accessories)

Dimensions (mm)

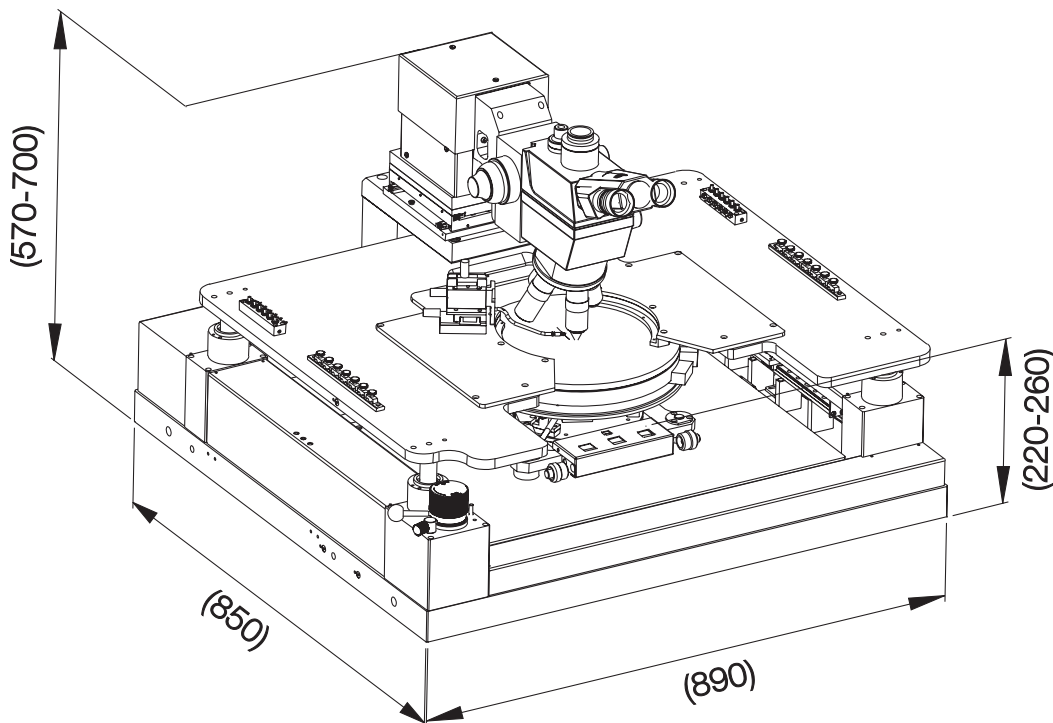

## APPLICATIONS

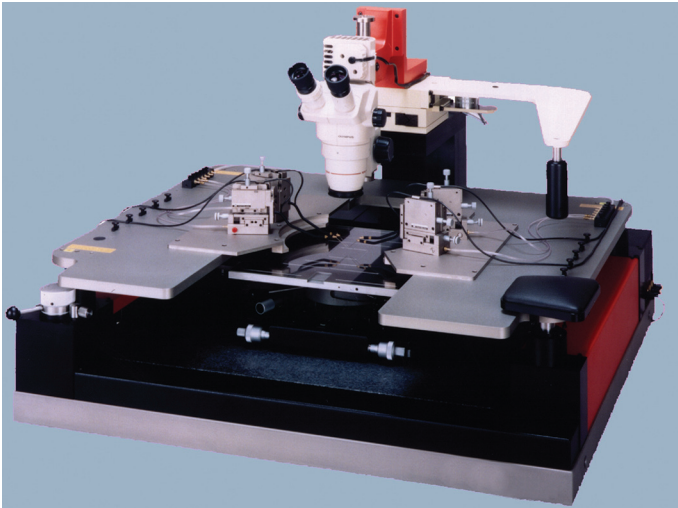

PM300 with square chuck for failure analysis of FPDs.

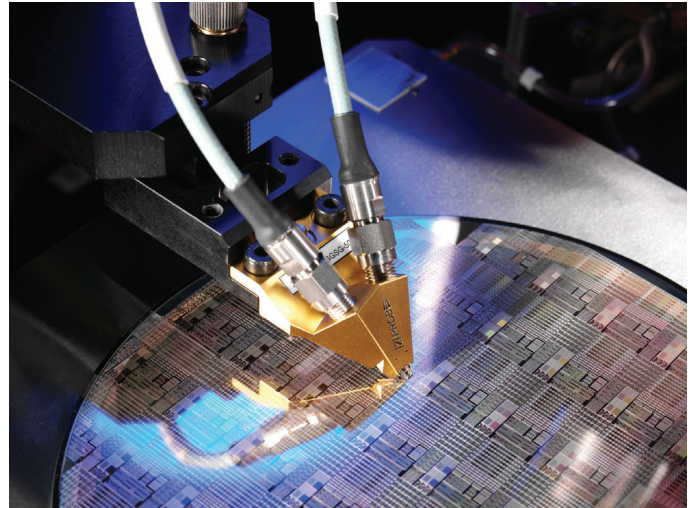

RF setup with Dual |Z| Probe® on PM300.

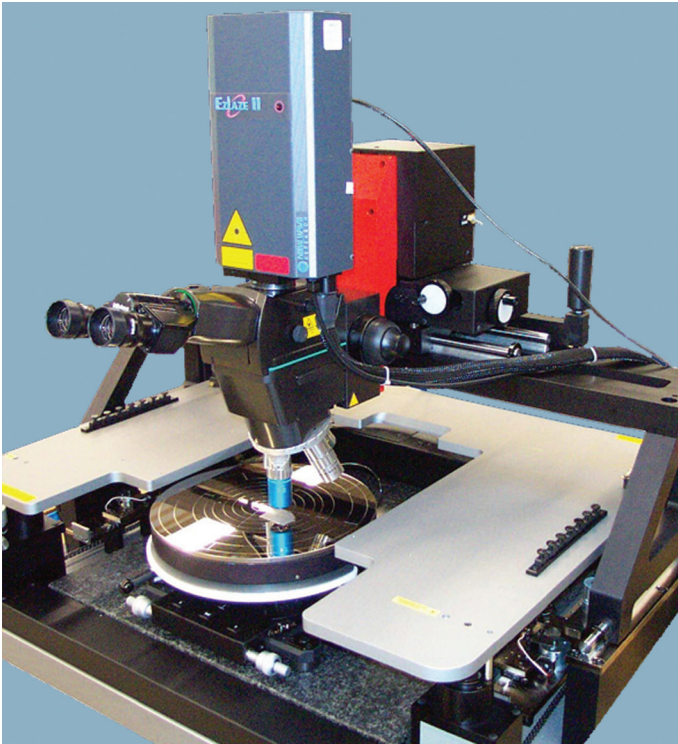

PM300 with laser cutter and 300 mm x 300 mm microscope movement.

© Copyright 2012 Cascade Microtech, Inc.  
All rights reserved. Cascade Microtech and |Z| Probe are registered trademarks, and ShieldEnclosure is a trademark of Cascade Microtech, Inc. All other trademarks are the property of their respective owners.

Data subject to change without notice

PM300-DS-0212

**Cascade Microtech, Inc.  
Corporate Headquarters**  
toll free: +1-800-550-3279  
phone: +1-503-601-1000  
email: [cmi\\_sales@cmicro.com](mailto:cmi_sales@cmicro.com)

**Germany**  
phone: +49-89-9090195-0  
email: [cmg\\_sales@cmicro.com](mailto:cmg_sales@cmicro.com)

**Japan**  
phone: +81-3-5615-5150  
email: [cmj\\_sales@cmicro.com](mailto:cmj_sales@cmicro.com)

**China**  
phone: +86-21-3330-3188  
email: [cmc\\_sales@cmicro.com](mailto:cmc_sales@cmicro.com)

**Singapore**  
phone: +65-6873-7482  
email: [cms\\_sales@cmicro.com](mailto:cms_sales@cmicro.com)

**Taiwan**  
phone: +886-3-5722810  
email: [cmt\\_sales@cmicro.com](mailto:cmt_sales@cmicro.com)

PM300

[www.cascademicrotech.com](http://www.cascademicrotech.com)

