

# R&S®SGS100A

## SGMA RF Source

### User Manual



This document describes the R&S®SGS100A, stock no. 1416.0505.02 and its options.

- R&S®SGS-B1 (1416.2408.02)
- R&S®SGS-B26 (1416.1353.02)
- R&S®SGS-B106/106V (1416.2308.02/1416.2350.02)
- R&S®SGS-B112/112V (1416.1553.02/1416.1576.02)
- R&S®SGS-K22 (1416.2650.02)
- R&S®SGS-K90 (1416.2608.02)

This manual describes firmware version FW 4.30.046.xx and later of the R&S®SGS100A.

© 2019 Rohde & Schwarz GmbH & Co. KG

Mühlhofstr. 15, 81671 München, Germany

Phone: +49 89 41 29 - 0

Fax: +49 89 41 29 12 164

Email: [info@rohde-schwarz.com](mailto:info@rohde-schwarz.com)

Internet: [www.rohde-schwarz.com](http://www.rohde-schwarz.com)

Subject to change – Data without tolerance limits is not binding.

R&S® is a registered trademark of Rohde & Schwarz GmbH & Co. KG.

Trade names are trademarks of the owners.

1173.9105.02 | Version 12 | R&S®SGS100A

Throughout this manual, products from Rohde & Schwarz are indicated without the ® symbol , e.g. R&S®SGS is indicated as R&S SGS.

# Safety Instructions

## Instrucciones de seguridad

## Sicherheitshinweise

## Consignes de sécurité

---

### **WARNING**

#### **Risk of injury and instrument damage**

The instrument must be used in an appropriate manner to prevent electric shock, fire, personal injury or instrument damage.

- Do not open the instrument casing.
  - Read and observe the "Basic Safety Instructions" delivered as printed brochure with the instrument.
  - Read and observe the safety instructions in the following sections. Note that the data sheet may specify additional operating conditions.
  - Keep the "Basic Safety Instructions" and the product documentation in a safe place and pass them on to the subsequent users.
- 

### **ADVERTENCIA**

#### **Riesgo de lesiones y daños en el instrumento**

El instrumento se debe usar de manera adecuada para prevenir descargas eléctricas, incendios, lesiones o daños materiales.

- No abrir la carcasa del instrumento.
  - Lea y cumpla las "Instrucciones de seguridad elementales" suministradas con el instrumento como folleto impreso.
  - Lea y cumpla las instrucciones de seguridad incluidas en las siguientes secciones. Se debe tener en cuenta que las especificaciones técnicas pueden contener condiciones adicionales para su uso.
  - Guarde bien las instrucciones de seguridad elementales, así como la documentación del producto, y entréguelas a usuarios posteriores.
-

---

**⚠️ WARNUNG****Gefahr von Verletzungen und Schäden am Gerät**

Betreiben Sie das Gerät immer ordnungsgemäß, um elektrischen Schlag, Brand, Verletzungen von Personen oder Geräteschäden zu verhindern.

- Öffnen Sie das Gerätegehäuse nicht.
  - Lesen und beachten Sie die "Grundlegenden Sicherheitshinweise", die als gedruckte Broschüre dem Gerät beiliegen.
  - Lesen und beachten Sie die Sicherheitshinweise in den folgenden Abschnitten; möglicherweise enthält das Datenblatt weitere Hinweise zu speziellen Betriebsbedingungen.
  - Bewahren Sie die "Grundlegenden Sicherheitshinweise" und die Produktdokumentation gut auf und geben Sie diese an weitere Benutzer des Produkts weiter.
- 

---

**⚠️ AVERTISSEMENT****Risque de blessures et d'endommagement de l'appareil**

L'appareil doit être utilisé conformément aux prescriptions afin d'éviter les électrocutions, incendies, dommages corporels et matériels.

- N'ouvrez pas le boîtier de l'appareil.
  - Lisez et respectez les "consignes de sécurité fondamentales" fournies avec l'appareil sous forme de brochure imprimée.
  - Lisez et respectez les instructions de sécurité dans les sections suivantes. Il ne faut pas oublier que la fiche technique peut indiquer des conditions d'exploitation supplémentaires.
  - Gardez les consignes de sécurité fondamentales et la documentation produit dans un lieu sûr et transmettez ces documents aux autres utilisateurs.
-

# Contents

<b>1</b>	<b>Preface</b> .....	<b>13</b>
1.1	<b>Key Features</b> .....	<b>13</b>
1.2	<b>Documentation Overview</b> .....	<b>13</b>
1.2.1	Getting Started Manual.....	13
1.2.2	User Manual and Help.....	13
1.2.3	Service Manual.....	14
1.2.4	Instrument Security Procedures.....	14
1.2.5	Basic Safety Instructions.....	14
1.2.6	Data Sheets and Brochures.....	14
1.2.7	Release Notes and Open Source Acknowledgment (OSA).....	14
1.2.8	Application Notes, Application Cards, White Papers, etc.....	15
1.3	<b>Typographical Conventions</b> .....	<b>15</b>
<b>2</b>	<b>Preparing for Use</b> .....	<b>16</b>
2.1	<b>Putting into Operation</b> .....	<b>16</b>
2.1.1	EMI Suppression.....	17
2.1.2	Unpacking and Checking the Instrument.....	17
2.1.3	Accessory List.....	18
2.1.4	Placing or Mounting the Instrument.....	18
2.1.5	Switching the Instrument On and Off.....	19
2.1.6	Function Check.....	21
2.1.7	Default Settings.....	21
2.2	<b>Linux Operating System</b> .....	<b>22</b>
2.3	<b>Connecting an External PC and Devices</b> .....	<b>22</b>
2.3.1	Installing the R&S SGMA-GUI Software.....	23
2.3.2	Connecting a Remote PC via LAN.....	24
2.3.2.1	Connecting the Instrument to the Network.....	25
2.3.2.2	Assigning the IP Address.....	26
2.3.2.3	Automatically Adding Instruments to the SGMA-GUI .....	27
2.3.3	Connecting a Controller via PCI Express.....	28
2.3.4	Connecting a Controller or a USB Device via USB.....	28
<b>3</b>	<b>Instrument Tour</b> .....	<b>31</b>

3.1	Front Panel Tour.....	31
3.2	Rear Panel Tour.....	33
<b>4</b>	<b>First Steps with the Instrument.....</b>	<b>36</b>
4.1	Configuring a CW Signal with the R&S SGMA-GUI.....	36
4.2	Configuring a CW Signal with the R&S SGS100A Web-GUI.....	38
<b>5</b>	<b>System Overview.....</b>	<b>40</b>
5.1	Setups for Instrument Control.....	40
5.1.1	Manual Operation from the R&S SGMA-GUI.....	40
5.1.2	Remote Control from a Controller.....	41
5.1.3	Control of an R&S SGS from an R&S Signal Generator.....	41
5.2	Setups for Connecting an R&S SGS and an R&S SGU.....	42
5.2.1	Direct Connection.....	42
5.2.2	Connection in a Company Network.....	43
5.2.3	Connection with a PCIe Switch.....	46
5.2.4	R&S SGU as an Extension to the R&S SGS.....	47
5.3	Introduction to the Instrument Functions.....	51
<b>6</b>	<b>Understanding the R&amp;S SGMA-GUI Software.....</b>	<b>53</b>
6.1	Operating Menu and Toolbar.....	53
6.1.1	File Menu.....	54
6.1.2	Setup Menu.....	55
6.1.2.1	Configure Instruments.....	55
6.1.2.2	Add/Edit Instruments.....	57
6.1.2.3	Versions/Options Dialog.....	59
6.1.2.4	Protection.....	60
6.1.2.5	Reset SGMA-GUI.....	61
6.1.2.6	Remote.....	61
6.1.3	Help.....	62
6.2	Info Dialog and Messages in the Info Bar.....	62
6.2.1	Info Dialog.....	62
6.2.2	Understanding the Messages in the Info Bar.....	63
6.3	Main Panel.....	64
6.4	Working with R&S SGMA-GUI.....	67

6.4.1	Storing and Loading Settings.....	67
6.4.2	Handling Instruments in the R&S SGMA-GUI.....	68
6.4.2.1	How to Automatically Add New Instruments to the SGMA-GUI .....	68
6.4.2.2	How to Manually Add New Instruments to the SGMA-GUI .....	68
6.4.2.3	How to Scan for New Instruments.....	69
6.4.2.4	How to Activate Instruments for Control from the R&S SGMA-GUI.....	69
6.4.2.5	How to Edit Instruments.....	69
6.4.2.6	How to Delete an Instrument.....	70
6.4.2.7	How to Delete All Instruments.....	70
6.4.2.8	How to Reserve the Instrument for Control.....	70
6.4.3	Finding Out the Default Hostname of the Instrument.....	71
6.4.4	Bidirectional Instrument Identification .....	71
6.4.5	Managing Messages in the Info Dialog.....	73
<b>6.5</b>	<b>Remote Control of the R&amp;S SGMA-GUI.....</b>	<b>74</b>
6.5.1	Configuring Instruments in the R&S SGMA-GUI.....	74
6.5.2	R&S SGMA-GUI Settings.....	75
6.5.3	List of R&S SGMA-GUI Commands.....	79
<b>7</b>	<b>Signal Generator Settings.....</b>	<b>80</b>
<b>7.1</b>	<b>Operation Mode.....</b>	<b>80</b>
<b>7.2</b>	<b>Frequency/Phase Settings.....</b>	<b>80</b>
<b>7.3</b>	<b>Local Oscillator (LO) Coupling.....</b>	<b>82</b>
7.3.1	Phase Coherence.....	82
7.3.2	Local Oscillator (LO) Coupling Settings.....	83
<b>7.4</b>	<b>Reference Oscillator.....</b>	<b>84</b>
<b>7.5</b>	<b>Level and Power-On Settings.....</b>	<b>87</b>
7.5.1	RF Level.....	88
7.5.2	Attenuator.....	90
7.5.3	Power-On/EMF.....	92
7.5.4	ALC .....	92
7.5.5	User Correction Settings.....	93
7.5.6	Filling the Correction List Automatically.....	98
7.5.7	Fill with Sensor.....	99
7.5.8	Using Power Sensors.....	101

7.5.8.1	Connecting R&S NRP Power Sensors to the R&S SGS.....	102
7.5.8.2	NRP Sensor Mapping.....	103
7.5.8.3	NRP Power Viewer.....	105
	About.....	105
	NRP Power Viewer Settings.....	107
<b>7.6</b>	<b>Pulse Modulation.....</b>	<b>112</b>
7.6.1	Pulse Modulation Settings.....	114
7.6.2	Pulse Generator Settings.....	115
7.6.3	Pulse Connector/Trigger Settings.....	116
<b>7.7</b>	<b>Trigger Connector Settings.....</b>	<b>117</b>
<b>7.8</b>	<b>I/Q Modulation and Signal Impairment.....</b>	<b>118</b>
7.8.1	I/Q Impairments.....	118
7.8.1.1	Gain and Gain Imbalance.....	119
7.8.1.2	I and Q Offset.....	120
7.8.1.3	Quadrature Offset.....	120
7.8.2	General I/Q Settings.....	121
7.8.3	Analog Impairment Settings.....	122
<b>7.9</b>	<b>Preset.....</b>	<b>123</b>
<b>7.10</b>	<b>Extension.....</b>	<b>124</b>
<b>8</b>	<b>General Instrument Settings and Instrument Setup.....</b>	<b>128</b>
<b>8.1</b>	<b>Internal Adjustments.....</b>	<b>128</b>
<b>8.2</b>	<b>Hardware Configuration.....</b>	<b>130</b>
<b>8.3</b>	<b>Software / Options.....</b>	<b>132</b>
<b>8.4</b>	<b>Install SW-Options.....</b>	<b>133</b>
<b>8.5</b>	<b>NRP Info.....</b>	<b>134</b>
<b>8.6</b>	<b>Protection.....</b>	<b>134</b>
<b>8.7</b>	<b>Security Setting.....</b>	<b>135</b>
<b>8.8</b>	<b>Maintenance.....</b>	<b>138</b>
<b>8.9</b>	<b>Network Settings.....</b>	<b>139</b>
<b>8.10</b>	<b>Remote Channels.....</b>	<b>142</b>
<b>8.11</b>	<b>Factory Preset.....</b>	<b>142</b>
<b>8.12</b>	<b>Eco Mode.....</b>	<b>143</b>
<b>8.13</b>	<b>Standby and Restart.....</b>	<b>144</b>

<b>8.14</b>	<b>Diagnostic and Tests</b> .....	<b>144</b>
8.14.1	Self-test.....	145
8.14.2	Keyboard Tests.....	145
<b>8.15</b>	<b>External Adjustments</b> .....	<b>146</b>
<b>9</b>	<b>Performing Configuration Tasks</b> .....	<b>147</b>
9.1	How to Generate an I/Q Modulated Signal.....	147
9.2	How to Generate I/Q Signals with an R&S SGS and an R&S SGU Upconverter.	149
9.3	How to Enable a Baseband Bypass Mode.....	151
9.4	How to Configure the Reference Oscillator Source.....	152
9.5	How to Configure the Local Oscillator (LO) Coupling Source.....	153
9.6	How to Define the Signal at the REF/LO OUT Connector.....	154
9.7	How to Connect and Configure Instruments for Optimum Phase Coherence....	154
9.8	How to Restore the LAN Connection to an Instrument.....	155
9.9	How to Switch between the Operating States.....	156
9.10	How to Use Computer Names.....	158
9.11	How to Optimize Performance.....	158
9.12	How to Install a New Firmware Version on the Instrument.....	159
9.13	How to Activate Options.....	161
9.14	How to Manually Set a PCIe Direct Connection between an R&S SGS and an R&S SGU.....	161
<b>10</b>	<b>Network and Remote Control Operation</b> .....	<b>162</b>
10.1	Remote Control Interfaces and Protocols.....	162
10.1.1	Remote Control Programs and Libraries.....	163
10.1.2	LAN Interface.....	165
10.1.2.1	VISA Resource Strings.....	166
10.1.2.2	HiSLIP Protocol.....	167
10.1.2.3	VXI-11 Protocol.....	168
10.1.2.4	Socket Communication.....	168
10.1.3	USB Interface.....	168
10.1.4	PCI Express Interface.....	169
10.1.5	GPIB Interface (IEC/IEEE Bus Interface).....	170
10.2	Starting a Remote Control Session.....	170
10.2.1	How to Find the VISA Resource String.....	171

10.2.2	Example: Remote Control over LAN Using Socket Communication.....	171
<b>10.3</b>	<b>Advanced Remote Control Using PCIe.....</b>	<b>172</b>
10.3.1	Setting Up a Remote Control Connection via PCIe.....	173
10.3.2	Download the Drivers.....	173
10.3.3	Configuring the Controller.....	174
10.3.3.1	Building and Installing the Hardware Driver.....	174
10.3.3.2	Making Shared Libraries Accessible.....	175
10.3.3.3	Building a Program.....	175
10.3.4	Connecting the Controller and the Instrument.....	176
10.3.5	Enabling Fast Settings.....	177
<b>10.4</b>	<b>Advanced Remote Control Using Fast Socket.....</b>	<b>177</b>
10.4.1	Setting Up a Remote Control Connection via Fast Socket.....	178
10.4.2	Installing the Protocol Driver.....	179
10.4.3	Enabling Fast Settings.....	179
<b>10.5</b>	<b>LXI Configuration.....</b>	<b>179</b>
10.5.1	Default State of the Network Settings.....	180
10.5.2	LXI Browser Settings.....	180
10.5.3	LAN Configuration.....	181
10.5.3.1	IP Configuration.....	182
10.5.3.2	Advanced Config.....	182
10.5.3.3	Ping Client.....	183
10.5.3.4	SCPI Remote Trace.....	184
10.5.4	How to Record SCPI Commands and Messages exchanged via the LXI Web Browser Interface.....	186
<b>10.6</b>	<b>Using the R&amp;S SGMA-GUI to Monitor the Remote Control Operation.....</b>	<b>187</b>
<b>11</b>	<b>Remote Control Commands.....</b>	<b>190</b>
<b>11.1</b>	<b>Programming Examples.....</b>	<b>191</b>
11.1.1	Performing General Task for Instrument Setup.....	191
11.1.2	Generating an I/Q Modulated Signal.....	193
11.1.3	Adjusting Network and Remote Channel Settings.....	195
11.1.4	Advanced Task for Optimizing Performance.....	196
11.1.5	Enabling and Configuring an Extension Mode.....	197
<b>11.2</b>	<b>Common Commands.....</b>	<b>199</b>

11.3	<b>General Commands</b> .....	203
11.4	<b>Preset Commands</b> .....	204
11.5	<b>CALibration Subsystem</b> .....	205
11.6	<b>CONNector Subsystem</b> .....	208
11.7	<b>DIAGnostic Subsystem</b> .....	209
11.8	<b>EXTension Subsystem</b> .....	209
11.9	<b>MMEMory Subsystem</b> .....	213
11.9.1	File Naming Conventions.....	213
11.9.2	Extensions for User Files.....	214
11.9.3	Examples.....	214
11.9.4	Remote Control Commands.....	215
11.10	<b>Fast Speed Commands</b> .....	221
11.11	<b>OUTPut Subsystem</b> .....	222
11.12	<b>SENSe, READ, INITiate and SLISt Subsystems</b> .....	223
11.13	<b>SOURce Subsystem</b> .....	235
11.14	<b>SOURce:CORRection Subsystem</b> .....	237
11.15	<b>SOURce:IQ Subsystem</b> .....	246
11.16	<b>SOURce:PHASe Subsystem</b> .....	248
11.17	<b>SOURce:POWer Subsystem</b> .....	249
11.18	<b>SOURce:PULM Subsystem</b> .....	253
11.19	<b>SOURce:ROSCillator Subsystem</b> .....	259
11.20	<b>STATus Subsystem</b> .....	261
11.21	<b>SYSTem Subsystem</b> .....	265
11.22	<b>TEST Subsystem</b> .....	278
11.23	<b>UNIT Subsystem</b> .....	279
11.24	<b>List of R&amp;S SGS Commands</b> .....	279
12	<b>Maintenance</b> .....	285
12.1	<b>Cleaning</b> .....	285
12.2	<b>Storing and Packing</b> .....	286
13	<b>Error Messages and Troubleshooting</b> .....	287
13.1	<b>Status Information</b> .....	287
13.2	<b>Error Messages</b> .....	287
13.2.1	Volatile messages.....	287

13.2.2	Permanent messages.....	288
<b>13.3</b>	<b>SCPI-Error Messages.....</b>	<b>288</b>
<b>13.4</b>	<b>Device-Specific Error Messages.....</b>	<b>288</b>
	<b>Annex.....</b>	<b>291</b>
	<b>A Remote Control Basics.....</b>	<b>291</b>
<b>A.1</b>	<b>Messages.....</b>	<b>291</b>
<b>A.2</b>	<b>LAN Interface Messages.....</b>	<b>292</b>
<b>A.3</b>	<b>SCPI Command Structure.....</b>	<b>292</b>
A.3.1	Syntax for Common Commands.....	293
A.3.2	Syntax for Device-Specific Commands.....	293
A.3.2.1	Long and short form.....	294
A.3.2.2	Numeric Suffixes.....	294
A.3.2.3	Optional Mnemonics.....	294
A.3.3	SCPI Parameters.....	295
A.3.3.1	Numeric Values.....	295
A.3.3.2	Special Numeric Values.....	296
A.3.3.3	Boolean Parameters.....	297
A.3.3.4	Text Parameters.....	297
A.3.3.5	Character Strings.....	297
A.3.3.6	Block Data.....	297
A.3.4	Overview of Syntax Elements.....	298
A.3.5	Structure of a Command Line.....	299
A.3.6	Responses to Queries.....	300
<b>A.4</b>	<b>Command Sequence and Synchronization.....</b>	<b>301</b>
A.4.1	Preventing Overlapping Execution.....	301
<b>A.5</b>	<b>Status Reporting System.....</b>	<b>302</b>
A.5.1	Hierarchy of the Status Registers.....	302
A.5.2	Structure of a SCPI Status Register.....	304
A.5.3	Status Byte (STB) and Service Request Enable Register (SRE).....	306
A.5.4	Event Status Register (ESR) and Event Status Enable Register (ESE).....	307
A.5.5	Questionable Status Register (STATus:QUEStionable).....	307
A.5.6	Operation Status Register (STATus:OPERation).....	308
A.5.7	Application of the Status Reporting System.....	308

A.5.7.1	Service Request.....	308
A.5.7.2	Serial Poll.....	309
A.5.7.3	Query of an instrument status.....	309
A.5.7.4	Error Queue.....	309
A.5.8	Reset Values of the Status Reporting System.....	310
<b>A.6</b>	<b>General Programming Recommendations.....</b>	<b>310</b>
<b>B</b>	<b>Telnet program examples.....</b>	<b>312</b>
	<b>Index.....</b>	<b>317</b>



# 1 Preface

The R&S SGS is a signal generator intended either for the generation of IQ-modulated signals or as a pure local oscillator (LO) source.

Optimized for use in automated test equipment (ATE), the instrument offers fast settling times in an exceptionally small form factor and low power consumption. The R&S SGS can be equipped optionally with an active electronic step attenuator, a high stability reference oscillator and LO connectors for coupling multiple generators to a common LO source.

## 1.1 Key Features

The key features of the R&S SGS include the following:

- Compact size and low power consumption
- Remote connection via PCI Express, minimizing the setup time  
Alternatively, LAN or USB connections available
- Coherent LO input and output connectors, also usable as MIMO input/output and phase coherent I/Q demodulation
- Broadband analog input for vector modulation (I, Q)
- Linux operating system
- Graphical user interface R&S SGMA-GUI to set up and control one or more R&S SGS instruments simultaneously from one remote computer, available for Windows and Linux systems

## 1.2 Documentation Overview

This section provides an overview of the R&S SGS user documentation. Unless specified otherwise, you find the documents on the R&S SGS product page at:

[www.rohde-schwarz.com/manual/sgs100a](http://www.rohde-schwarz.com/manual/sgs100a)

### 1.2.1 Getting Started Manual

Introduces the R&S SGS and describes how to set up and start working with the product. Includes basic operations, typical measurement examples, and general information, e.g. safety instructions, etc. A printed version is delivered with the instrument.

### 1.2.2 User Manual and Help

Contains the description of all instrument modes and functions. It also provides an introduction to remote control, a complete description of the remote control commands

with programming examples, and information on maintenance, instrument interfaces and error messages. Includes the contents of the getting started manual.

The contents of the user manuals are available as help in the R&S SGS. The help offers quick, context-sensitive access to the complete information.

All user manuals are also available for download or for immediate display on the Internet.

### 1.2.3 Service Manual

Describes the performance test for checking the rated specifications, module replacement and repair, firmware update, troubleshooting and fault elimination, and contains mechanical drawings and spare part lists.

The service manual is available for registered users on the global Rohde & Schwarz information system (GLORIS, <https://gloris.rohde-schwarz.com>).

### 1.2.4 Instrument Security Procedures

Deals with security issues when working with the R&S SGS in secure areas. It is available for download on the Internet.

### 1.2.5 Basic Safety Instructions

Contains safety instructions, operating conditions and further important information. The printed document is delivered with the instrument.

### 1.2.6 Data Sheets and Brochures

The data sheet contains the technical specifications of the R&S SGS. It also lists the options and their order numbers and optional accessories.

The brochure provides an overview of the instrument and deals with the specific characteristics.

See [www.rohde-schwarz.com/brochure-datasheet/sgs100a](http://www.rohde-schwarz.com/brochure-datasheet/sgs100a)

### 1.2.7 Release Notes and Open Source Acknowledgment (OSA)

The release notes list new features, improvements and known issues of the current firmware version, and describe the firmware installation.

The open source acknowledgment document provides verbatim license texts of the used open source software.

See [www.rohde-schwarz.com/firmware/sgs100a](http://www.rohde-schwarz.com/firmware/sgs100a)

### 1.2.8 Application Notes, Application Cards, White Papers, etc.

These documents deal with special applications or background information on particular topics.

See [www.rohde-schwarz.com/application/sgs100a](http://www.rohde-schwarz.com/application/sgs100a).

## 1.3 Typographical Conventions

The following text markers are used throughout this documentation:

Convention	Description
"Graphical user interface elements"	All names of graphical user interface elements on the screen, such as dialog boxes, menus, options, buttons, and softkeys are enclosed by quotation marks.
[Keys]	Key and knob names are enclosed by square brackets.
Filenames, commands, program code	Filenames, commands, coding samples and screen output are distinguished by their font.
<i>Input</i>	Input to be entered by the user is displayed in italics.
<a href="#">Links</a>	Links that you can click are displayed in blue font.
"References"	References to other parts of the documentation are enclosed by quotation marks.

## 2 Preparing for Use

- [Putting into Operation](#)..... 16
- [Linux Operating System](#).....22
- [Connecting an External PC and Devices](#).....22

### 2.1 Putting into Operation

This section describes the basic steps to be taken when setting up the R&S SGS for the first time.

#### **WARNING**

##### **Risk of injury and instrument damage**

The instrument must be used in an appropriate manner to prevent electric shock, fire, personal injury, or damage.

- Do not open the instrument casing.
- Read and observe the "Basic Safety Instructions" delivered as a printed brochure with the instrument.

In addition, read and observe the safety instructions in the following sections.

Notice that the data sheet may specify additional operating conditions.

#### **NOTICE**

##### **Risk of instrument damage due to inappropriate operating conditions**

Specific operating conditions are required to ensure accurate measurements and to avoid damage to the instrument. Observe the information on appropriate operating conditions provided in the basic safety instructions and the instrument's data sheet.

#### **NOTICE**

##### **Instrument damage caused by electrostatic discharge**

Electrostatic discharge (ESD) can damage the electronic components of the instrument and the device under test (DUT). Electrostatic discharge is most likely to occur when you connect or disconnect a DUT or test fixture to the instrument's test ports. To prevent electrostatic discharge, use a wrist strap and cord and connect yourself to the ground, or use a conductive floor mat and heel strap combination.

**NOTICE****Risk of instrument damage due to inappropriate operating conditions**

An unsuitable operating site or test setup can damage the instrument and connected devices. Before switching on the instrument, observe the information on appropriate operating conditions provided in the data sheet. In particular, ensure the following:

- All fan openings are unobstructed and the airflow perforations are unimpeded. A minimum distance of 10 cm to other objects is recommended.
- The instrument is dry and shows no sign of condensation.
- The instrument is positioned as described in the following sections.
- The ambient temperature does not exceed the range specified in the data sheet.
- Signal levels at the input connectors are all within the specified ranges.
- Signal outputs are connected correctly and are not overloaded.

**2.1.1 EMI Suppression**

Electromagnetic interference (EMI) may affect the measurement results.

To suppress generated Electromagnetic Interference (EMI):

- Use suitable shielded cables of high quality. For example, use double-shielded RF and LAN cables.  
**Note:** USB cables are of varying and often poor quality. Therefore, check the quality of each individual USB cable as described in the service manual.
- Always terminate open cable ends.
- Note the EMC classification in the data sheet

**2.1.2 Unpacking and Checking the Instrument**

Unpack the R&S SGS carefully and check the contents of the package.

- Check if all items listed on the delivery note, including this getting started manual, are included in the delivery.
- Check the R&S SGS for any damage.  
If the contents are damaged, immediately contact the carrier who delivered the package.

**Packing material**

Retain the original packing material. If the instrument needs to be transported or shipped later, you can use the material to protect the control elements and connectors.

**⚠ WARNING****Risk of injury during transportation**

The carrying handles at the front and side of the casing are designed to lift or carry the instrument. Do not apply excessive force to the handles. If a handle is ripped off, the falling instrument can cause injury.

**2.1.3 Accessory List**

The instrument comes with the following accessories:

- Power cable
- Getting started printed manual

**2.1.4 Placing or Mounting the Instrument**

The R&S SGS is designed for use under laboratory conditions, either on a bench top or in a rack using a rack adapter kit (order number see data sheet).

**Bench top operation**

If the R&S SGS is operated on a bench top, the surface should be flat. The instrument can be used in horizontal position, standing on its feet.

**CAUTION****Risk of injury and instrument damage if stacking instruments**

A stack of instruments may tilt over and cause injury. Furthermore, the instruments at the bottom of the stack may be damaged due to the load imposed by the instruments on top.

Observe the following instructions when stacking instruments:

- Never stack more than three instruments with the same dimensions (width and length). If you need to stack more than three instruments, install them in a rack.
- The overall load imposed on the lowest instrument must not exceed 500 N.
- All instruments should have the same dimensions (width and length).  
If you need to stack smaller instruments on the top, the overall load imposed on the lowest instrument must not exceed 250 N.
- If the instruments have foldable feet, fold them in completely.

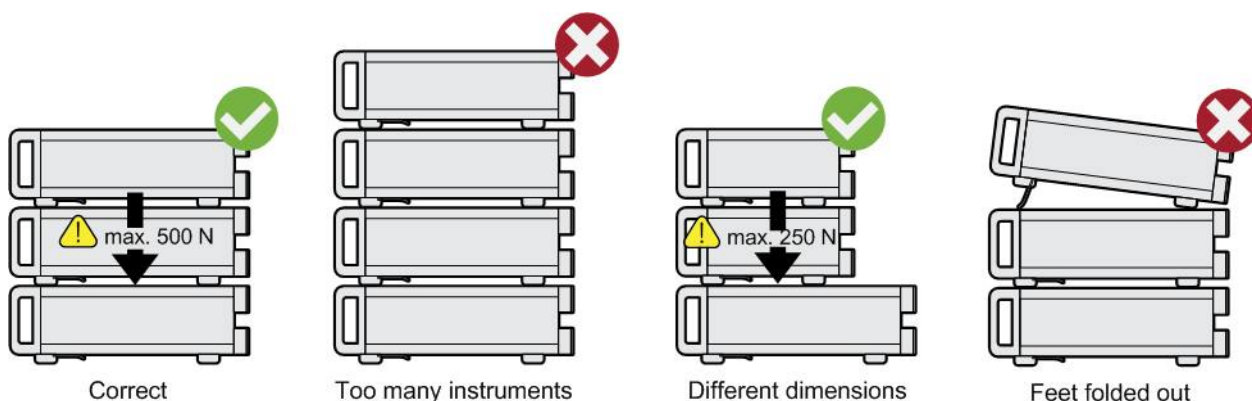
**Rack mounting**

The R&S SGS can be installed in a rack using a rack adapter kit (Order No. see data sheet). The installation instructions are part of the adapter kit.

**NOTICE****Risk of instrument damage due to insufficient airflow in a rack**

If you mount several instruments in a rack, you need an efficient ventilation concept to ensure that the instruments do not overheat. Insufficient airflow for a longer period can disturb the operation and even cause damage.

**2.1.5 Switching the Instrument On and Off**

The R&S SGS is automatically adapted to the AC voltage supplied. There is no need to set the voltage manually or change fuses. The [\[AC supply and power switch\]](#) is at the rear of the unit.

### To connect the AC supply

- ▶ Connect the R&S SGS to the AC power source using the AC power cable delivered with the instrument.

**Note:** The instrument is in compliance with safety class EN61010-1. Connect the instrument only to a socket with earthing contact.

### To start up the instrument

1. Connect the instrument to the AC supply.



2. To turn on the power, press the main power switch to position I (On).

### To switch between standby and ready state

- ▶ Press the [POWER ON /STAND BY] key briefly to switch the instrument from the standby to ready state or vice versa.



In ready state, the button is green. The instrument is ready for operation. All modules are power-supplied and the R&S SGS initiates its startup procedure.

In standby state, the button is orange. The standby power mode keeps the power switch circuits and the remote control system active.

### Start-up and booting

The instrument boots the operating system and starts the instrument firmware. During the booting process, the green [POWER ON /STAND BY] key blinks. If the previous session was terminated regularly, the instrument uses the last setup with the relevant instrument settings.

Once the startup procedure has been terminated, the instrument is ready for operation.



In the R&S SGMA-GUI, select "Instrument > Preset" function to return the instrument to its defined reset/preset state, if the current setup is no longer relevant.

---

To customize the start settings, use the "SGMA-GUI > File > Save As/Open" function.

### To shut down the instrument

To shut down the R&S SGS, proceed as described below.

**NOTICE****Risk of losing data**

If you switch off the running instrument using the rear panel switch or by disconnecting the power cord, the instrument loses its current settings.

Always press the [POWER ON/STANDBY] key first to shut down the application properly.

1. Press the [POWER ON /STAND BY] key to save the current setup, shut down the operating system and set the instrument to standby state.

The [POWER ON /STAND BY] LED must be orange.

**Tip:** If the instrument is operated manually via the R&S SGMA-GUI, select "SGMA-GUI > Instrument Name > Setup > Standby".

2. To turn the power off, press the main power switch to position 0 (Off).

None of the front-panel LEDs should be on.

### 2.1.6 Function Check

The instrument automatically monitors the main functions when it is switched on and monitors them continuously during operation.

A detected fault is indicated by an "Error" message displayed in the info line of the R&S SGMA-GUI together with a brief error description. For an in-depth identification of the error, press the "SGMA-GUI > Info" button. In response, a description of the errors is displayed. For more information, refer to the "Error Messages" section in the user manual.

In addition to the automatic monitoring, the R&S SGS offers the following capabilities to ensure correct functioning:

- Internal Adjustments  
In the R&S SGMA-GUI, select the "Instrument > Setup > Internal Adjustments" dialog to access the dialog for performing and configuring the adjustments settings. A maximum level accuracy can be obtained, for instance.
- Selftest  
A selftest is provided for service purposes ("SGMA-GUI > Instrument > Diagnostic/ Test > Self Test").

### 2.1.7 Default Settings

When the instrument is switched on, it is not the preset state that is active, but rather the instrument state that was set before the instrument was switched off. It is recommended that you use the "SGMA-GUI > Instrument > Preset" function to return the instrument to its defined preset state every time a new configuration is required or the current setup is no longer relevant.

The R&S SGS offers a two-stage preset concept:

- Preset the instrument to a predefined state  
The "SGMA-GUI > Instrument Name > Preset" function calls up a defined instrument setup. All parameters and switching states are preset (also these of inactive operating modes). The default instrument settings provide a reproducible initial basis for all other settings. However, functions that concern the integration of the instrument into a measurement setup are not changed.
- Preset the instrument to its factory settings  
The instrument can also be forced to load its default factory settings. To access the corresponding dialog box, select the "SGMA-GUI > Instrument Name > Setup > Factory Preset" function.  
For more information and an overview of the settings affected by the factory preset function, see [Chapter 8.11, "Factory Preset"](#), on page 142.



User-defined instrument states can be stored and called up using the functions "SGMA-GUI > File > Save As/Open".

---

## 2.2 Linux Operating System

The instrument uses an embedded Linux operating system, optimally adapted to the instrument.



### Accessing the operating system

No access to the operating system is required for normal operation.  
All necessary system settings can be made in the "Setup" dialog.

---

## 2.3 Connecting an External PC and Devices

As a rule, the R&S SGS is operated exclusively via remote control on a connected PC. Another way to control the instrument is the manual operation via the R&S SGMA-GUI software on the connected PC.

Both the remote control and the manual operation of the instrument require an external controller. For the prerequisites and the instructions on how to configure an external controller for remote control, refer to the user manual. A brief introduction to the remote control capabilities is provided in [Chapter 10, "Network and Remote Control Operation"](#), on page 162.

This section gives an introduction on how to configure the external PC for manual operation (see [Chapter 2.3.1, "Installing the R&S SGMA-GUI Software"](#), on page 23).

In addition to connecting an external controller, it may be useful to connect other external devices, e.g. a memory stick. The following interfaces are provided on the rear panel of the instrument, see also [Chapter 3.2, "Rear Panel Tour"](#), on page 33:

- PCI Express (refer to [Chapter 2.3.3, "Connecting a Controller via PCI Express"](#), on page 28)
- USB interface (refer to [Chapter 2.3.4, "Connecting a Controller or a USB Device via USB"](#), on page 28)
- LAN interface (refer to [Chapter 2.3.2, "Connecting a Remote PC via LAN"](#), on page 24)

### 2.3.1 Installing the R&S SGMA-GUI Software

The R&S SGMA-GUI software is a graphical user interface program for one or more instruments. It runs on a remote PC.

The R&S SGMA-GUI software is provided as separate installation package for the different operating systems. The latest version of the software together with the release notes is available for download at:

<http://www.rohde-schwarz.com/product/SGS100A.html> > "Downloads" > "Software"

This page always offers the latest information on your R&S SGMA-GUI.



This description focuses on the handling of the Windows-32 version. The file naming conventions and the installation instructions for the other operating systems are analogous.

The R&S SGMA-GUI installation package for Windows-32 operating system consists of the file `SGMA-GUI_<V.VV.VVV.VVV>.exe`. The version numbers in the file names vary with each update. To install the R&S SGMA-GUI, the following hardware and software requirements have to be met.

**Table 2-1: Hardware and software requirements**

Requirement	Remark
One of the following operating systems: <ul style="list-style-type: none"> <li>• Windows Vista</li> <li>• Windows 7</li> <li>• Windows 8/ 8.1</li> <li>• Windows 10</li> <li>• Linux</li> </ul>	R&S SGMA-GUI has to be installed on one of the supported operating systems. Also, the version of the operating system must be still supported by Microsoft. <b>Note:</b> Any other Windows version or other operating systems are not supported. During installation, the operation system is checked. The installation is terminated if this requirement is not fulfilled.
R&S VISA	VISA drivers can be obtained on the Rohde & Schwarz website: <a href="http://www.rohde-schwarz.com/rsvisa">http://www.rohde-schwarz.com/rsvisa</a>
CPU	At least Pentium or compatible, as from 1 GHz (recommended).
VGA color display resolution	At least 800*600 pixels

### Installing a new software version



Administrator rights are necessary for installation and starting.

1. Download the R&S SGMA-GUI software.
2. In Windows Explorer, double-click `SGMA-GUI_V.VV.VVV.VVV.exe`. Follow the instructions.

After the installation of the R&S SGMA-GUI software, two icons will be shown in your Windows menu: one is the standard version and one for which the remote command of the software through SCPIs is disabled. The SCPI disabled version allows you to install and use the R&S SGMA-GUI on other instruments, without interfering with the remote control of the host instrument.

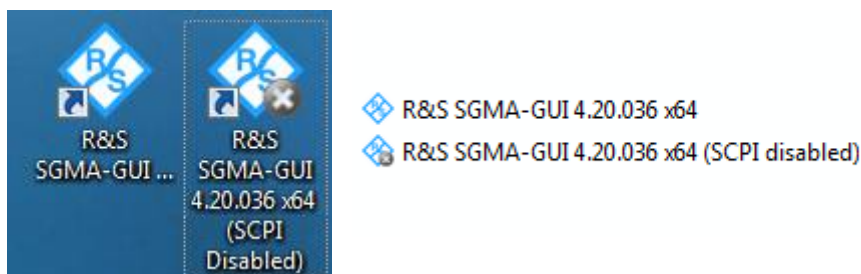

Start the version that is required for your application.

### Uninstalling an old software version

An uninstallation of a previous version of the SW can be performed before the installation of the new one, but this is not mandatory.

- ▶ To uninstall this version, go to "Start > Settings > Control Panel > Add/Remove Programs" and select the entry `SGMA-GUI_V.VV.VVV.VVV`.

The script file identifies and removes all currently installed R&S SGMA-GUI software items.

## 2.3.2 Connecting a Remote PC via LAN

The R&S SGS is equipped with a network interface and can be connected to an Ethernet LAN (local area network). The interface can be used, for example:

- To connect an external computer for manual control of the instrument by the R&S SGMA-GUI software.
- To operate the device by a remote control program.  
See [Chapter 10, "Network and Remote Control Operation"](#), on page 162.

This section describes how to configure the LAN interface. It includes the following topics:

- [Chapter 2.3.2.1, "Connecting the Instrument to the Network"](#), on page 25
- [Chapter 2.3.2.2, "Assigning the IP Address"](#), on page 26
- [Chapter 2.3.2.3, "Automatically Adding Instruments to the SGMA-GUI"](#), on page 27

### 2.3.2.1 Connecting the Instrument to the Network

There are two methods to establish a LAN connection to the instrument:

- A non-dedicated network (Ethernet) connection from the instrument to an existing network.
- A dedicated network connection (Point-to-point connection) between the instrument and a single computer.

In both cases, an IP address has to be assigned to the instrument and the computer, see [Chapter 2.3.2.2, "Assigning the IP Address"](#), on page 26.

---

#### **NOTICE**

##### **Risk of network failure**

Consult your network administrator before performing the following tasks:

- Connecting the instrument to the network
- Configuring the network
- Changing IP addresses

Errors can affect the entire network.

---

##### **Setting up a non-dedicated network (LAN) connection**

- ▶ Connect the instrument to the network or to a single PC.

If the instrument is connected to the LAN, the operating system automatically detects the network connection and activates the required drivers.

By default, the instrument is configured to use dynamic TCP/IP configuration and obtain all address information automatically.

##### **Setting up a dedicated network connection**

If your network does not support DHCP, you can set a dedicated network connection between a stand-alone PC and a R&S SGS

Prerequisite: the computer and the R&S SGS are turned on and running.

1. Start the R&S SGMA-GUI.
2. Connect the computer and the R&S SGS with a LAN network cable.
3. Wait for about one minute for the automatic assignment of IP addresses to complete.

4. R&S SGMA-GUI main panel, select "Setup > Instruments".
5. In the "Configure Instruments" dialog, click "Scan".  
The new instrument should appear with a Zeroconf IP address 169.254.xx.yy
6. Assign a static IP address to the instrument, see ["Assigning a static IP address to the R&S SGS"](#) on page 26.
7. Assign a static IP address to the PC, see ["Assigning a static IP address to your Windows-PC network card"](#) on page 27.
8. Edit the instrument settings, see [Chapter 6.4.2.5, "How to Edit Instruments"](#), on page 69

### 2.3.2.2 Assigning the IP Address

Depending on the network capacities, the TCP/IP address information for the instrument can be obtained in different ways.

- If the network supports dynamic TCP/IP configuration using the Dynamic Host Configuration Protocol (DHCP), all address information can be assigned automatically.
- If the network does not support DHCP, the instrument tries to obtain the IP address via Zeroconf (APIPA) protocol. If this attempt does not succeed or if the instrument is set to use alternate TCP/IP configuration, the addresses must be set manually, see ["Setting up a dedicated network connection"](#) on page 25.



The R&S SGS uses the Zeroconf IP addresses 169.254.xxx.yyy., where xxx takes values between 1...254 and yyy the values in the value range 1...255; the subnet mask is always 255.255.0.0. The IP address of the host must be within the same address area for Zeroconf.

By default, the instrument is configured to use dynamic TCP/IP configuration and obtain all address information automatically. This means that it is safe to establish a physical connection to the LAN without any previous instrument configuration.

#### Assigning a static IP address to the R&S SGS

Prerequisites: A connection is established between the R&S SGS and the controller with installed SGMA-GUI.

For how to setup a LAN connection, see [Chapter 2.3.2.1, "Connecting the Instrument to the Network"](#), on page 25.

For how to set up a USB connection, see ["Setting up a USB connection from a PC to the R&S SGS"](#) on page 29.

1. Open "SGMA-GUI > Instrument > Setup > Network Settings" dialog.
2. Set the "Address Mode" to "Static".
3. Enter the "IP Address", for example *192.168.0.1..*

4. Enter the "Subnet mask", for example *255.255.255.0*.
5. Enter the "Default Gateway", for example *192.168.0.1*.

#### Assigning a static IP address to your Windows-PC network card

1. Obtain the IP address and subnet mask for the R&S SGS and the IP address for the local default gateway from your network administrator. If necessary, also obtain the name of your DNS domain and the IP addresses of the DNS and WINS servers on your network. If you use more than one LAN connector, you need separate address information for each connector.
2. Press the "Windows" key to access the operating system.
3. Open the "Control Panel" by selecting "Start > Settings > Control Panel".
4. Select "Network and Sharing Center".
5. In the left panel, click "Change adapter settings".
6. Select the network adapter you want to change. Click "Change settings of this connection".
7. On the "Networking" tab, click "Internet Protocol Version 4 (TCP/IPv4)". Select "Properties".
8. Select "Use the following IP address" and enter the address information as obtained from the network administrator.
9. If necessary, you can also select "Use the following DNS server addresses" and enter your own DNS addresses.

For more information, refer to your Windows system Help.

#### 2.3.2.3 Automatically Adding Instruments to the SGMA-GUI



For information on how to install the R&S SGMA-GUI software, refer to [Chapter 2.3.1, "Installing the R&S SGMA-GUI Software"](#), on page 23.

1. For each new instrument perform the following steps:
  - a) Connect the instrument to the network.
  - b) Press the [POWER ON /STAND BY] key to switch on the instrument.
  - c) Wait until the [POWER ON /STAND BY] LED is green and not blinking.
  - d) Press the [ID] key on the front panel of the instrument.
2. Start the SGMA-GUI on a computer connected to the same network.
3. Open the "Instruments" dialog and click "Scan".

**Note:** This step is performed automatically on the first start and can also be omitted for instruments with a direct LAN connection to the computer.

All instruments are added automatically to the main panel of the SIGMA-GUI.

### 2.3.3 Connecting a Controller via PCI Express

A PCI Express connector is provided on the rear panel of the instrument, see [Chapter 3.2, "Rear Panel Tour"](#), on page 33.

#### **NOTICE**

##### **Risk of device failure**

The R&S SGS is equipped with a single lane PCIe interface that supports hot plugging. Do not connect an external PC to the PCIe connector of the instrument during operation if this external PC does not support hot-plugging!

Using the PCIe interface for remote control of the instrument requires extended knowledge. Refer to [Chapter 10.3, "Advanced Remote Control Using PCIe"](#), on page 172 for detailed information.

### 2.3.4 Connecting a Controller or a USB Device via USB

The USB interface on the rear panel of the R&S SGS allows you to connect either a USB device or use the R&S SGS as a device and connect it to a controller.

#### **Connecting a controller (host PC or compatible signal generator)**

If you connect a controller (host PC or compatible signal generator) to the R&S SGS, the R&S SGS acts as a USB device.

To connect the controller to the USB interface of the R&S SGS, always connect the **USB type Micro-B** connector to the R&S SGS. Refer to the documentation of the controller to find out which USB connector type you can connect to the controller.

The [Figure 2-1](#) illustrates schematically the required connector type to emphasize on the different connector shape.

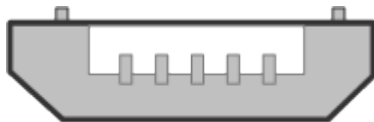

*Figure 2-1: USB type Micro-B connectors*

An external PC with installed R&S SIGMA-GUI is required for manual operation of the R&S SGS.

### Setting up a USB connection from a PC to the R&S SGS

If your network does not support DHCP, you can set a USB connection between a PC and a R&S SGS.

Prerequisite: the computer and the R&S SGS are turned on and running.

1. Start the R&S SGMA-GUI.
2. Connect the computer and the R&S SGS with a USB cable.  
The new instrument should appear automatically.  
If the instrument does not appear automatically, you can open the "Setup > Instruments > Configure Instruments" dialog and click "Scan".
3. If your network does not support DHCP, you can now set a static IP address to your computer.
  - a) Assign a static IP address to the instrument, see ["Assigning a static IP address to the R&S SGS"](#) on page 26.
  - b) Assign a static IP address to the PC, see ["Assigning a static IP address to your Windows-PC network card"](#) on page 27.
  - c) Edit the instrument settings, see [Chapter 6.4.2.5, "How to Edit Instruments"](#), on page 69

### Connecting a USB device

If you connect a USB device (memory stick, CD-ROM, an instrument) to the R&S SGS, the R&S SGS acts as a host.

To connect a USB device to the interface of the R&S SGS, always connect the **USB type Micro-A** connector to the R&S SGS. Refer to the documentation of the USB device to find out which USB connector type you can connect to the USB device.

The [Figure 2-2](#) illustrates schematically the required connector type to emphasize on the different connector shape.

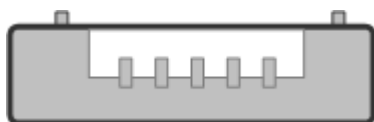

*Figure 2-2: USB type Micro-A connectors*

If you connect an R&S SGS to an R&S SGU via a USB cable, perform the steps as described in [Chapter 5.2, "Setups for Connecting an R&S SGS and an R&S SGU"](#), on page 42.



### Using a USB Adapter

You can use a USB adapter to customize the connectors of a USB cable to the requirements of the instrument.

For example, you can use a Type-A / Micro-A adapter to customize a standard USB cable with type A and type Micro-B connectors for the connection of an R&S SGS (acting as a host) to an R&S SGU (acting as a USB device).

In some cases, you can also use a Type-A / Micro-B adapter to establish a connection to the instrument. To check, whether the adapter you have is suitable or not you can connect a USB stick with an LED through the adapter to the instrument. If the LED of the USB stick lights up after a connection to the instrument then you can use this adapter for further applications with the instrument.

---

## 3 Instrument Tour

The following topics help you get familiar with the instrument and perform the first steps:

- [Front Panel Tour](#)
- [Rear Panel Tour](#)

This section explains the control elements and the connectors of the R&S SGS with the aid of the front and rear views. Specifications of interfaces can be found in the data sheet.

### 3.1 Front Panel Tour

This section provides an overview of control elements on the front panel of the R&S SGS. The connectors of the R&S SGS are placed on the rear panel and are described in [Chapter 3.2, "Rear Panel Tour"](#), on page 33. As the R&S SGS is intended to be remote-controlled, the front panel of the R&S SGS contains no display but mostly LEDs to inform you about the status of the instrument. The user interface can be displayed on a remote PC station used to manually remote control the instrument.



*Figure 3-1: Front panel view*

#### [POWER ON /STAND BY]



The [POWER ON /STAND BY] key switches the instrument from the standby to ready state or vice versa.

In ready state, the button is green. The instrument is ready for operation.

In standby state, the button is orange. In this state, it is safe to switch off the AC power and disconnect the instrument from the power supply.

A blinking green color indicates that a booting operation is in process.

#### [RF ON]



The [RF ON] key switches the RF signal on or off. If activated, the button is green.

#### [REF EXT]



The [REF EXT] LED indicates the status of the external reference.

- Green indicates that the instrument can synchronize to the external clock.
- Red indicates that the instrument cannot synchronize to the external clock.
- No light indicates that the internal reference is used.

#### [ERROR / WARNING]

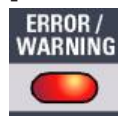

The [ERROR / WARNING] LED indicates the status of the R&S SGS.

- Red indicates that an error has occurred, e.g. temperature exceeded or power failure.
- Blinking orange indicates a running process (e.g. calibration, self test).
- No light indicates that no errors or warnings have occurred.

For details on errors or warnings, refer to the graphical user interface on a remote PC ("SGMA-GUI > Info").

For more information, refer to the "Error Messages" section in the user manual.

#### [LAN]



The [LAN] key indicates if a LAN connection is established.

Green LED indicates that a network cable is connected to the instrument and no error in the DHCP connection is detected. But it does not indicate that the remote control connection is established for all cases. For example, if the instrument is set to use a "Static" IP address the instrument may still not be visible in the network.

Pressing the key resets the LAN interface settings, i.e. the "IP Adress Mode" is reset to DHCP.

#### [ID]



Pressing the [ID] key while the instrument is active, opens the "SGMA-GUI > Setup > Instruments > Configure Instruments > Edit Instrument" dialog of the corresponding instrument on the remote controller.

Pressing the ID key of an inactive instrument and starting "SGMA-GUI > Setup > Instruments > Scan", leads to an automatic activation of the instrument in the SGMA-GUI.

## 3.2 Rear Panel Tour

This section provides an overview of the connectors on the rear panel of the instrument. For technical data of the connectors, refer to the data sheet.

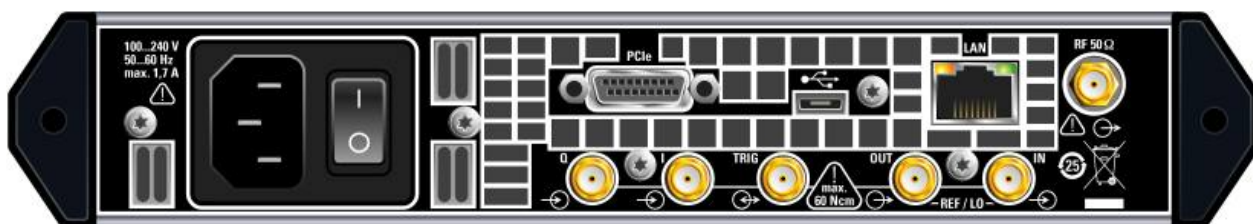

Figure 3-2: Rear panel view

### NOTICE

#### Risk of damaging components

Always use an appropriate 8 mm torque wrench to tighten SMA connectors. Limit the tightening torque to 60 Ncm. Never use an open-end wrench.

#### [PCI Express Connector]

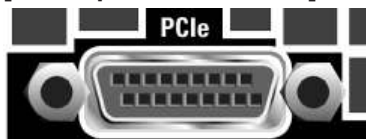

The PCIe (Peripheral Component Interconnect Express) single lane interface allows remote control with optimized speed.

For details, see [Chapter 2.3.3, "Connecting a Controller via PCI Express"](#), on page 28.

#### [USB Connector]



The USB (universal serial bus) interface, type micro, allows you to connect various external devices, e.g.:

- If the interface is configured as a device interface, the R&S SGS can be connected to other devices like a remote computer. On the computer, you can perform a firmware update, manual operation via the R&S SGMA-GUI software or for remote control of the instrument.

- If the interface is configured as a host interface, a memory stick for file transmission can be connected.

For details, see [Chapter 2.3.4, "Connecting a Controller or a USB Device via USB"](#), on page 28.

#### [LAN Connector]

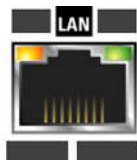

The [LAN] (Ethernet) interface allows you to connect the R&S SGS to other devices like a remote computer. On the computer, you can perform a firmware update, manual operation via the R&S SGMA-GUI software or for remote control of the instrument. The connection to the remote computer can be direct or via a network.

For details, see [Chapter 2.3.2, "Connecting a Remote PC via LAN"](#), on page 24.

#### [RF OUT]



Provides an RF 50 Ohm signal output.

**NOTICE!** Maximum input levels. Do not overload the RF output. The maximum permissible back-feed is specified in the data sheet.

#### [I, Q]



SMA female type connectors that are inputs of the I/Q modulator, provided for feeding of external signal.

**NOTICE!** Maximum input levels. Do not overload the I and Q inputs. The maximum permissible voltage is 1V. For details, refer to the data sheet.

**Note:** The I/Q modulator requires one of the hardware options R&S SGS-B106V/-B112V.

#### [REF / LO IN, REF / LO OUT]



SMA female type connectors, for reference or local oscillator signals, and alternatively also in MIMO setups.

Reference input and output:

- [REF IN]: Input for external reference signal.
- [REF OUT]: Output of internal reference signal.

Local oscillator input and output:

- [LO IN]: Input for external LO signals
- [LO OUT]: Output of internal LO signals.

**Note:** The local oscillator input/output requires the additional software option R&S SGS-K90.

#### [TRIG]



Multi-purpose connector. The [TRIG] connector is used mainly as an input connector for an external pulse modulator source.

#### [AC supply and power switch]



The AC supply and power switch allow you to connect the R&S SGS to the power supply and switch on the instrument.

For details, see ["To connect the AC supply"](#) on page 20.

## 4 First Steps with the Instrument

This section provides examples on how to configure the R&S SGS to generate a continuous wave (CW) signal via the R&S SGMA-GUI and the R&S SGS100A Web-GUI.

### 4.1 Configuring a CW Signal with the R&S SGMA-GUI

The R&S SGS in this example is a base unit equipped with the frequency option R&S SGS-B106.

As a prerequisite for this example, the R&S SGS has to be connected to a remote PC. The R&S SGMA-GUI software has to be installed on this remote PC and the instrument is added to the list of "Available Instruments".



Figure 4-1: Example of the setup



For information on how to fulfill these requirements, refer to

- [Chapter 2.3.2.1, "Connecting the Instrument to the Network"](#), on page 25
- [Chapter 2.3.1, "Installing the R&S SGMA-GUI Software"](#), on page 23
- [Chapter 2.3.2.3, "Automatically Adding Instruments to the SGMA-GUI"](#), on page 27

1. Check the front panel of the R&S SGS.  
The [POWER ON/STANDBY] and [LAN] key have to be **green**.
2. On the connected remote PC, start the R&S SGMA-GUI software application.  
The main panel of the application opens. The panel provides a quick access to the main settings of the configured and activated instruments. The display shows one row per instrument with the instrument-specific settings. The rows comprise the instrument, the connection state, the used frequency and power level, the state of the RF output and the modulator and the used reference frequency source.

## Configuring a CW Signal with the R&amp;S SGMA-GUI

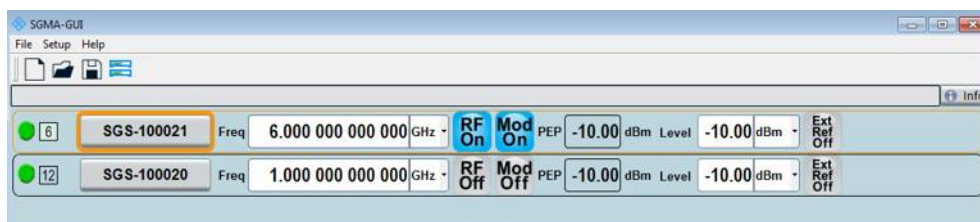

3. In the R&S SGMA-GUI main panel, the green indicator in front of the instrument's name confirms that there is a connection between the instrument and the remote PC and that the instrument is recognized by the software.
4. In the R&S SGMA-GUI main panel, select the row corresponding to the instrument to be configured and select "Instrument Name > Preset" to restore the predefined instrument's settings.

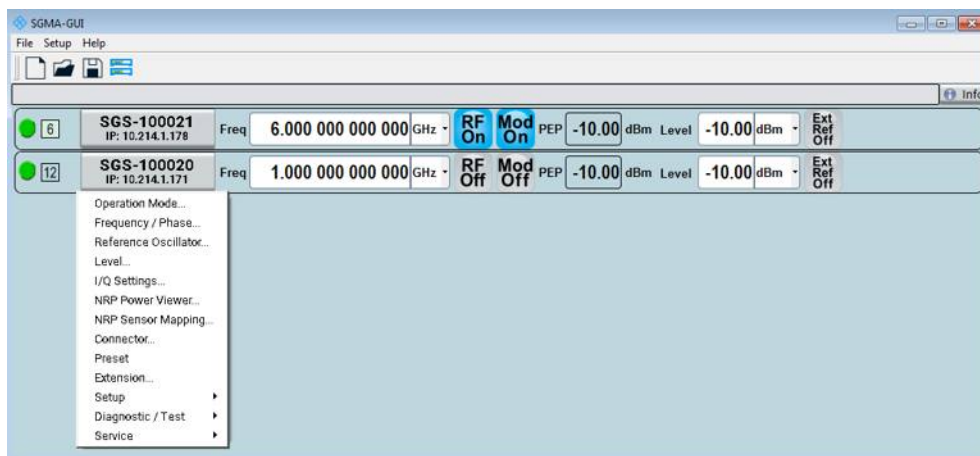

5. In the R&S SGMA-GUI main panel, select the row corresponding to the instrument to be configured and adjust the "Frequency" as required.

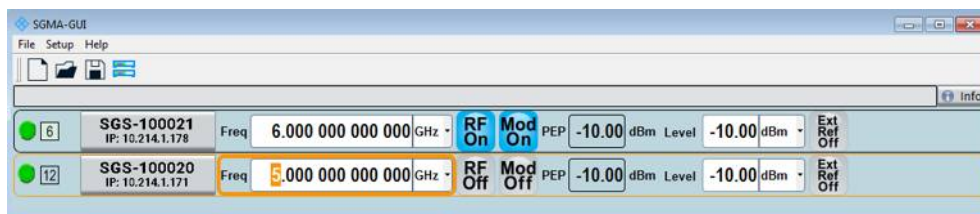

6. Select "SGMA-GUI > RF On" to enable the output of the CW signal.

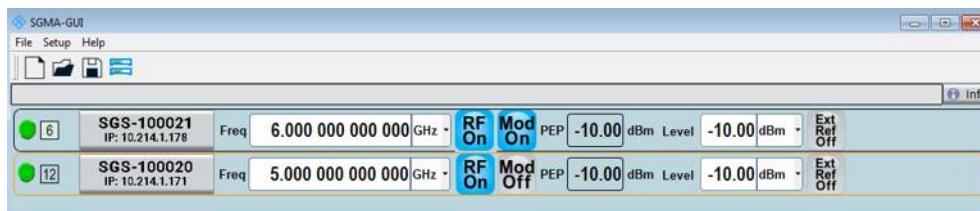

The 5 GHz signal is output at the [RF OUT] connector at the rear panel of the R&S SGS.



### Identifying a specific instrument

If several instruments are active in the R&S SGMA-GUI, use one of the device identification functions to identify a specific device:

- Select "SGMA-GUI > Instrument Name > Setup > Remote > Remote Channels > Device Identify". The green [LAN] LED on the front panel of the instrument blinks.
- Press the [ID] key on the instrument's front panel. The "Edit Instrument" dialog of the respective instrument opens.

## 4.2 Configuring a CW Signal with the R&S SGS100A Web-GUI

The R&S SGS100A Web-GUI is an alternative way to operate the R&S SGS. There is no installation needed. It can be used with all devices and operating systems, including tablets and smart phones, which have one of the following web browsers installed:

- Mozilla Firefox
- Google Chrome
- Microsoft Internet Explorer 9 or later

To connect to the R&S SGS from an external device, both of them must have access to the same network, i.e. use a shared network.

The feature set of the R&S SGS100A Web-GUI is limited to the most common settings, needed especially for modifying the output signal. For additional actions like firmware updates or adjustments, please use the R&S SGMA-GUI.

You can operate the R&S SGS100A Web-GUI and the R&S SGMA-GUI simultaneously. Furthermore you can enable the "Update" function (upper right corner) to allow an automatic update of the settings shown in the R&S SGS100A Web-GUI, if the settings were changed via other software.

As a prerequisite for this example, the R&S SGS has to be connected to the same network as the device used for controlling the instrument. Also one of the supported web browsers has to be available.

1. Check the front panel of the R&S SGS.  
The [POWER ON /STAND BY] and the [LAN] key have to be **green**.
2. Open a supported web browser.
3. Enter the instrument name or the IP address of the R&S SGS you want to connect to.

**Tip:** The default hostname of the instrument is a non case-sensitive string built as follows:

hostname = rssgs100a<serial number>, where

<serial number> is the individual serial number of the instrument.

The serial number is displayed at the rear side of the instrument. It is the third part of the device ID printed on the bar code sticker, see [Figure 4-2](#).



**Figure 4-2: Serial number of the R&S SGS100A**

The main panel of the R&S SGS100A Web-GUI opens.

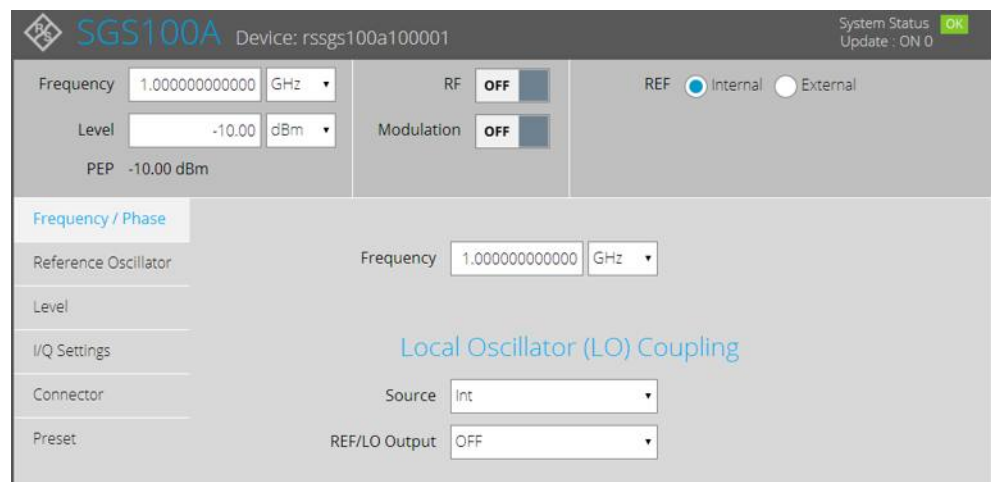

In the R&S SGS100A Web-GUI main panel, the green indicator "System Status > OK " confirms that there is a connection between the instrument and the remote PC and that the instrument is recognized by the software.

If you want to get additional information about the instrument, click on the "Device Name". For additional information on other settings, hold the mouse cursor over the specific setting.

Error messages are also displayed in the R&S SGS100A Web-GUI. If you want to hide an error message, click on it.

4. In the menu bar on the left side press "Preset" to restore the predefined instrument's settings.
5. Select "Frequency" and adjust the setting as required.
6. Select "RF On" to enable the output of the CW signal.

A signal with the set frequency is output at the [RF OUT] connector at the rear panel of the R&S SGS.

## 5 System Overview

The R&S SGS RF Source is a signal generator intended either for the generation of IQ-modulated signals or as a pure local oscillator (LO) source in the frequency range of 1 MHz to 12.75 GHz.

Optimized for use in automated test equipment (ATE), the instrument offers very fast settling times in an exceptionally small formfactor and low power consumption. The R&S SGS can be equipped optionally with an active electronic step attenuator, a high stability reference oscillator and LO connectors for coupling multiple generators to a common LO source.

### 5.1 Setups for Instrument Control

The R&S SGS is an instrument designed for the automated test equipment (ATE) needs. To maintain the small size, the instrument is not equipped with a display and hence additional equipment is required to control the instrument.

This section provides an overview of the possible configuration setups for controlling the R&S SGS.

#### 5.1.1 Manual Operation from the R&S SGMA-GUI

The following example represents a basic configuration of the R&S SGS, operated manually by the configuration software R&S SGMA-GUI. The configuration software is installed on a remote PC and controls several instruments. The instruments are connected to the remote PC over different remote control interfaces. Any combination of the used interfaces is possible.



*Figure 5-1: Configuration example: manual control from R&S SGMA-GUI*



For information about the manual control, refer to:

- [Chapter 6, "Understanding the R&S SGMA-GUI Software"](#), on page 53
- [Chapter 7, "Signal Generator Settings"](#), on page 80
- [Chapter 8, "General Instrument Settings and Instrument Setup"](#), on page 128

### 5.1.2 Remote Control from a Controller

The remote control provides access to the instrument's settings from a remote computer (external controller) by means of remote commands. To automate often repeating settings and settings sequences, these are grouped in the remote control programs, i.e. application programs.

An instrument may be connected to the controller via any of the supported interfaces LAN, USB or PCIe.

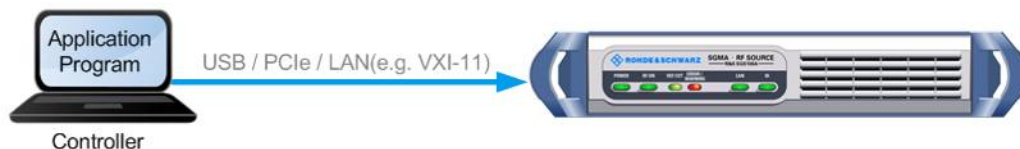

Figure 5-2: Configuration example: remote control from a controller



For information about remote control, refer to:

- [Chapter 10, "Network and Remote Control Operation"](#), on page 162
- [Chapter A, "Remote Control Basics"](#), on page 291

### 5.1.3 Control of an R&S SGS from an R&S Signal Generator

The R&S SGS can be used as an additional signal source to increase the number of available RF outputs of a R&S Signal Generator. In this setup, a controller does not need to access the R&S SGS directly. Instead, the signal generator acts as a controller to the R&S SGS and depending on the required output signal parameters performs all required settings automatically.

The [Figure 5-3](#) shows a configuration example of the R&S SGS, directly controlled by a R&S SMW.

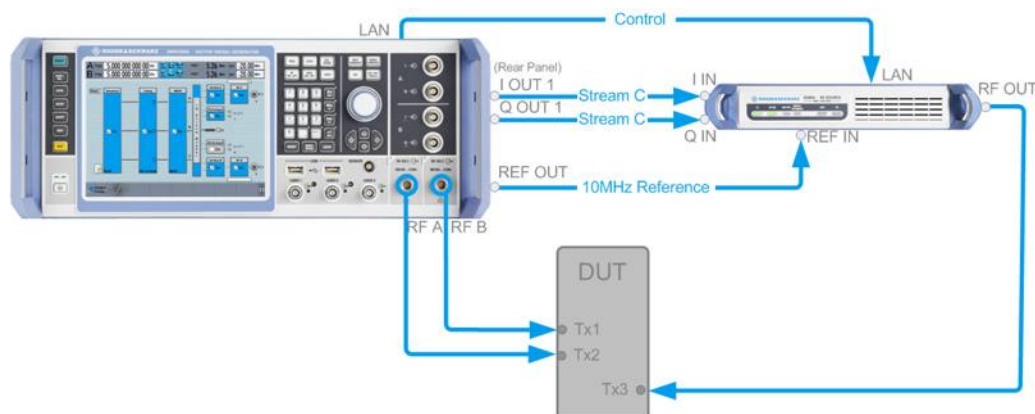

Figure 5-3: Configuration example: Control from a R&S SMW

## 5.2 Setups for Connecting an R&S SGS and an R&S SGU

If an R&S SGU is connected to an R&S SGS, the R&S SGU acts as an extension to the R&S SGS extending its frequency range. In this setup, a controller does not need to access the R&S SGU directly. Instead, the R&S SGS acts as a controller to the R&S SGU. The generator performs all required settings automatically depending on the required output signal parameters.

This chapter gives an overview of how to connect the instruments.

See:

- [Chapter 5.2.1, "Direct Connection"](#), on page 42
- [Chapter 5.2.2, "Connection in a Company Network"](#), on page 43
- [Chapter 5.2.3, "Connection with a PCIe Switch"](#), on page 46
- [Chapter 5.2.4, "R&S SGU as an Extension to the R&S SGS"](#), on page 47

### 5.2.1 Direct Connection

The R&S SGS and the R&S SGU can be connected through a direct connection as shown in [Figure 5-4](#).

#### Direct connection of an R&S SGS and an R&S SGU

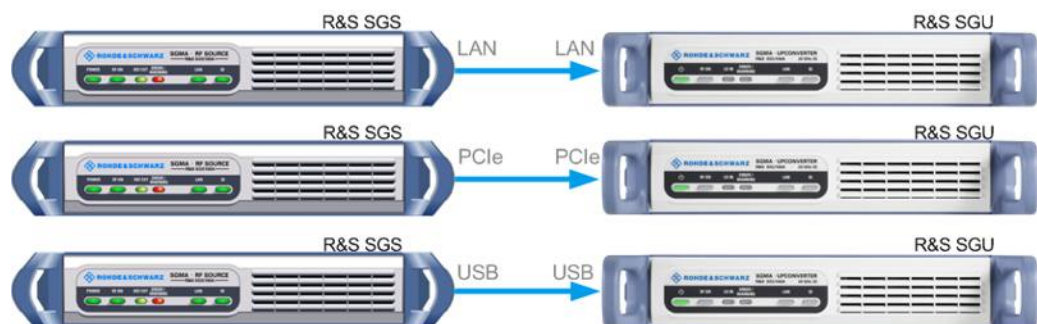

**Figure 5-4:** Direct connection of an R&S SGS and an R&S SGU

1. Connect the R&S SGS and the R&S SGU directly using one of the following options:
  - a) USB cable. Use a Type Micro-A connector for R&S SGS and a Type Micro-B connector for R&S SGU. See also [Chapter 2.3.4, "Connecting a Controller or a USB Device via USB"](#), on page 28.
  - b) LAN cable. No additional cable considerations are required.
  - c) PCIe cable. Refer to [Chapter 10.3.4, "Connecting the Controller and the Instrument"](#), on page 176 for cable requirements and setup information.
2. Switch on the R&S SGS and the R&S SGU.

The R&S SGS automatically identifies the connected R&S SGU as its extension and starts the extension mode.



For a direct PCIe connection, an automatic identification of the R&S SGU as an extension is only available for an R&S SGS with a "Controller > Revision" 5 or higher. For a description on how to manually set the PCIe identification, see [Chapter 9.14, "How to Manually Set a PCIe Direct Connection between an R&S SGS and an R&S SGU"](#), on page 161.

You can check the "Controller > Revision" of your instrument in the "SGMA-GUI > Instrument Name > Hardware Config" dialog.



#### If instrument is not automatically added as an extension

If the R&S SGU is not automatically added as an extension you can do that manually in the "SGMA-GUI > R&S SGS Name > Extension" dialog.

If the R&S SGU is not listed in the list of "Available Instruments", you can press "Scan > Start" to find the instrument.

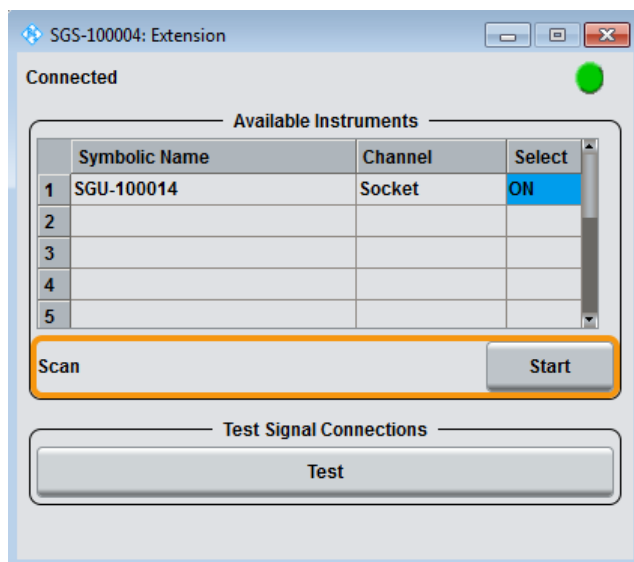

## 5.2.2 Connection in a Company Network

### Connection of an R&S SGS and an R&S SGU in a Company Network

As a prerequisite for this example the R&S SGMA-GUI software has to be installed on a remote PC.

## Setups for Connecting an R&amp;S SGS and an R&amp;S SGU



Figure 5-5: Connection of an R&S SGS and an R&S SGU in a company network

1. Connect the test equipment as shown in Figure 5-5:
  - a) Connect the R&S SGS, the R&S SGU and the controller to the company network.
  - b) Connect the [RF OUT] of the R&S SGS to the [LO IN] of the R&S SGU.
2. Switch on the R&S SGS and the R&S SGU.  
The [POWER ON/STANDBY] keys have to be **green** and not blinking.
3. Press the [ID] keys on the front panels of the R&S SGS and the R&S SGU.
4. On the connected remote PC, start the R&S SGMA-GUI software application.  
The main panel of the application and the configure instruments dialog open. Both instruments are added automatically to the instruments list and to the main panel of the R&S SGMA-GUI software.

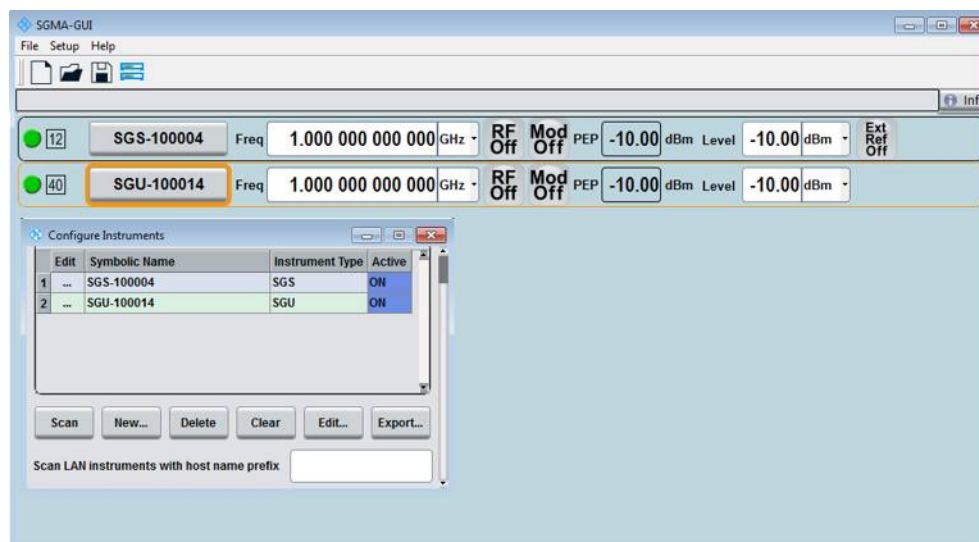

**Note:** If you connect the instruments to the company network for the first time this process may take several minutes.

5. In the R&S SGMA-GUI main panel, the green indicator in front of the instrument's name confirms that there is a connection between the instrument and the remote PC and that the instrument is recognized by the software.
6. Select "SGMA-GUI main panel > R&S SGS > Extension".  
The "Extension" dialog opens.

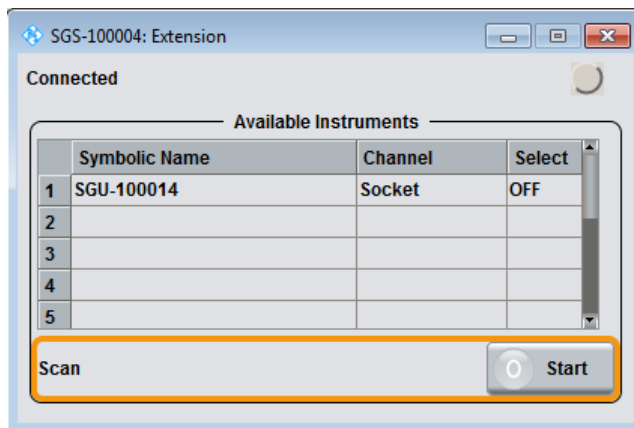

**Tip:** Instrument doesn't appear in the extension dialog. If the R&S SGU is not automatically shown in this dialog press "Scan > Start" to find the instrument.

7. Select the R&S SGU from the list and set "Available Instruments > Select > On" to enable it as an extension.

A green status indicator "Connected" indicates the successfully established remote connection between the R&S SGS and the R&S SGU.

The R&S SGMA-GUI indicates the extended frequency range of the R&S SGS and the activated extension mode.

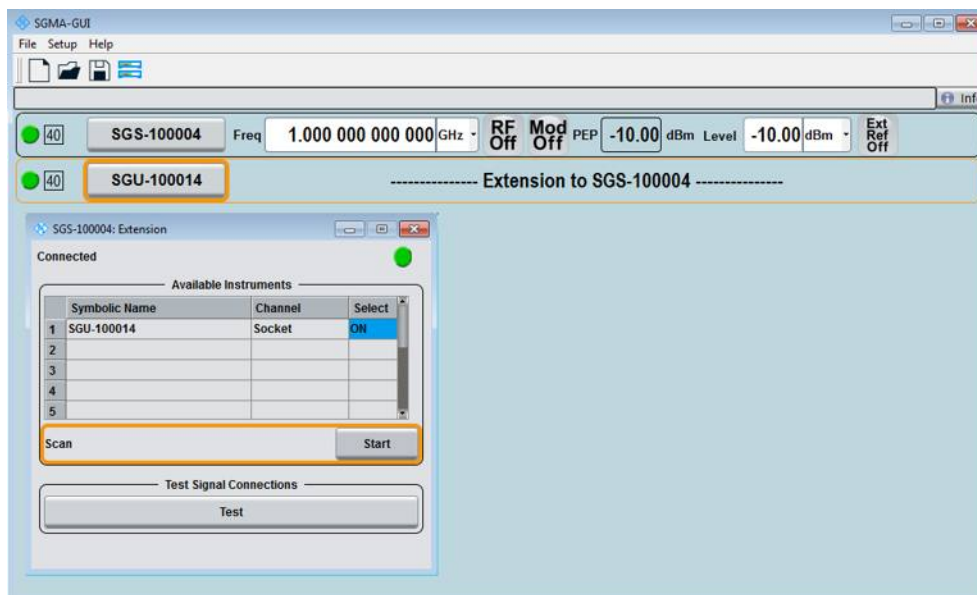

8. Select "Test Signal Connections > Test" to trigger a check of all required signal connections.

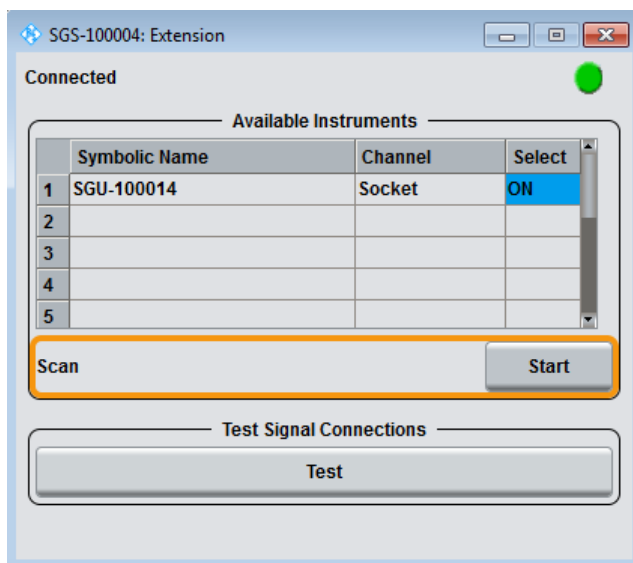

The diagram displays the connection state of the tested signal connections. If the test connections are correct (shown by an uninterrupted blue line), you can start using the R&S SGS and the R&S SGU in extension mode.

**Tip:** If your connection is marked as faulty- a red line is crossing the blue connection line - check whether the cables are connected properly. Check also if the connection cables are functioning properly.

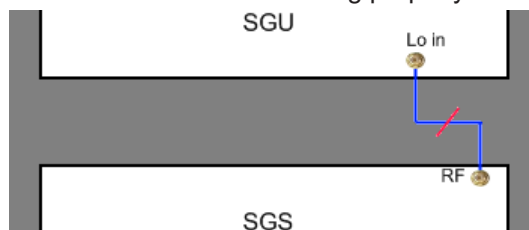

Figure 5-6: A faulty connection between an R&S SGU and an R&S SGS

### 5.2.3 Connection with a PCIe Switch

The R&S SGS and the R&S SGU can be connected through a PCIe switch as shown in Figure 5-7. This setup is recommended for achieving the highest setting/ measuring speeds.

### PCIe switch connection of an R&S SGS and an R&S SGU

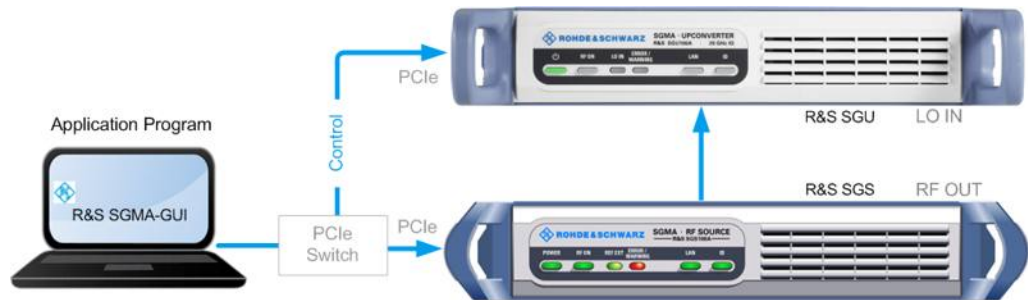

Figure 5-7: Connection of an R&S SGS and an R&S SGU through a PCIe switch

1. Connect the PCIe switch to a switched off computer with a single lane PCIe cable.
2. Connect the R&S SGS and the R&S SGU to the PCIe switch.
3. Switch on the R&S SGS and the R&S SGU.  
The [POWER ON/STANDBY] keys of both instruments have to be **green** and not blinking.
4. Switch on the computer.
5. On the computer start one of the following:
  - a) The R&S SGMA-GUI
  - b) An application program for remote control of the instruments
6. Manually (or remotely ) activate the R&S SGU as an extension to the R&S SGS.



The logical connection between an R&S SGS and an R&S SGU is established by the driver layer of a program (e.g. the R&S SGMA-GUI) or the library PCIeController.dll (Linux: libpciecontroller.so) of a remote control program on the PC. Such a program has to be running on the PC so that an R&S SGS is able to communicate with an R&S SGU.

#### 5.2.4 R&S SGU as an Extension to the R&S SGS

In case the R&S SGU is connected to a compatible R&S signal generator, a controller only needs to talk to the signal generator which in turn takes care of the proper settings for the R&S SGU.

In the following example, the instrument is manually operated via the R&S SGMA-GUI software. The R&S SGU in this example is a base unit equipped with the frequency option R&S SGU-B120.

##### Configuring the R&S SGU to upconvert a CW signal generated by the R&S SGS

As a prerequisite for this example the R&S SGMA-GUI software has to be installed on a remote PC.

## Setups for Connecting an R&amp;S SGS and an R&amp;S SGU

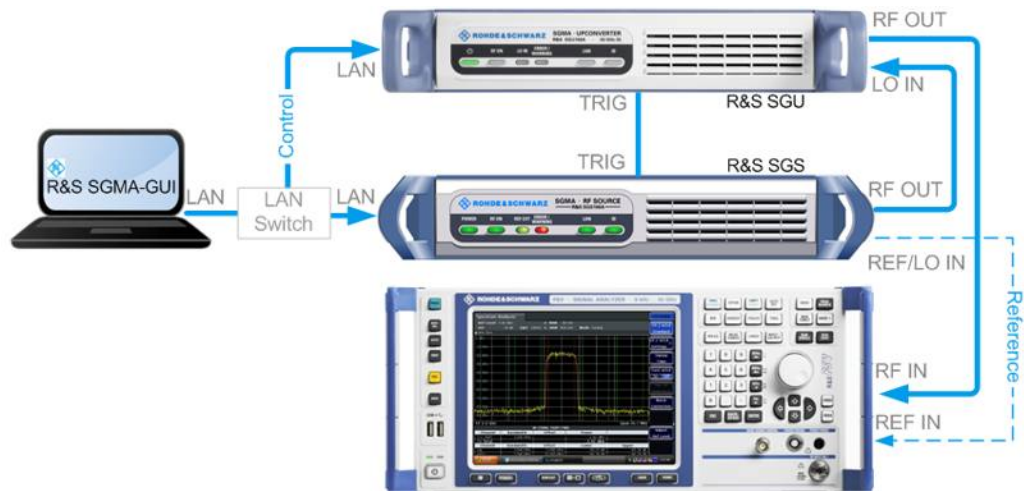

Figure 5-8: Example of a test setup for upconverting a CW signal generated by the R&S SGS



For higher setting/ measuring speeds, use a PCIe switch and PCIe connections.

1. Connect the test equipment as shown on [Figure 5-8](#):
  - a) Connect the R&S SGS, R&S SGU and the controller to a LAN switch.
  - b) Connect the [RF OUT] of the R&S SGS to the [LO IN] of the R&S SGU.
  - c) Connect the [TRIG] connectors of the R&S SGS and the R&S SGU.
  - d) Connect the [RF OUT] of the R&S SGU to the [RF IN] of the signal analyzer.
2. Switch on the R&S SGS and the R&S SGU.  
The [POWER ON/STANDBY] keys have to be **green** and not blinking.
3. Press the [ID] keys on the front panels of the R&S SGS and the R&S SGU (only required if the components are connected via a company network).
4. On the connected remote PC, start the R&S SGMA-GUI software application.  
The main panel of the application and the configure instruments dialog open. Both instruments are added automatically to the instruments list and to the main panel of the R&S SGMA-GUI software.  
The main panel provides a quick access to the main settings of the configured and activated instruments. The display shows one row per instrument with the instrument specific settings. The rows comprise the instrument, the connection state, the used frequency and power level and the state of the RF output and the modulator.

Setups for Connecting an R&S SGS and an R&S SGU

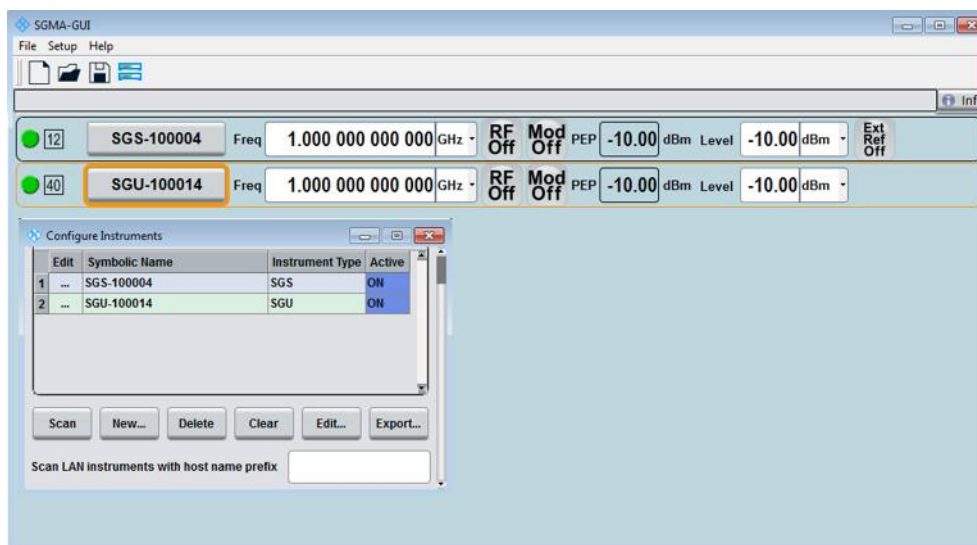

5. In the R&S SGMA-GUI main panel, the green indicator in front of the instrument's name confirms that there is a connection between the instrument and the remote PC and that the instrument is recognized by the software.
6. In the R&S SGMA-GUI main panel, select the rows corresponding to the corresponding instruments to be configured and select "Instrument Name > Preset" to restore their predefined settings.
7. Select "SGMA-GUI main panel > R&S SGS > Extension".  
The "Extension" dialog opens.

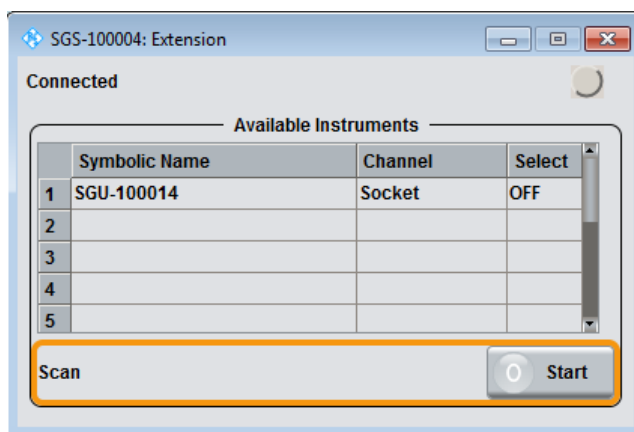

**Tip:** Instrument does not appear in the extension dialog. If the R&S SGU is not automatically shown in this dialog, press "Scan > Start" to find the instrument.

8. Select the R&S SGU from the list and set "Available Instruments > Select > On" to enable it as an extension.

A green status indicator "Connected" indicates the successfully established remote connection between the R&S SGS and the R&S SGU.

The R&S SGMA-GUI indicates the extended frequency range of the R&S SGS and the activated extension mode.

## Setups for Connecting an R&amp;S SGS and an R&amp;S SGU

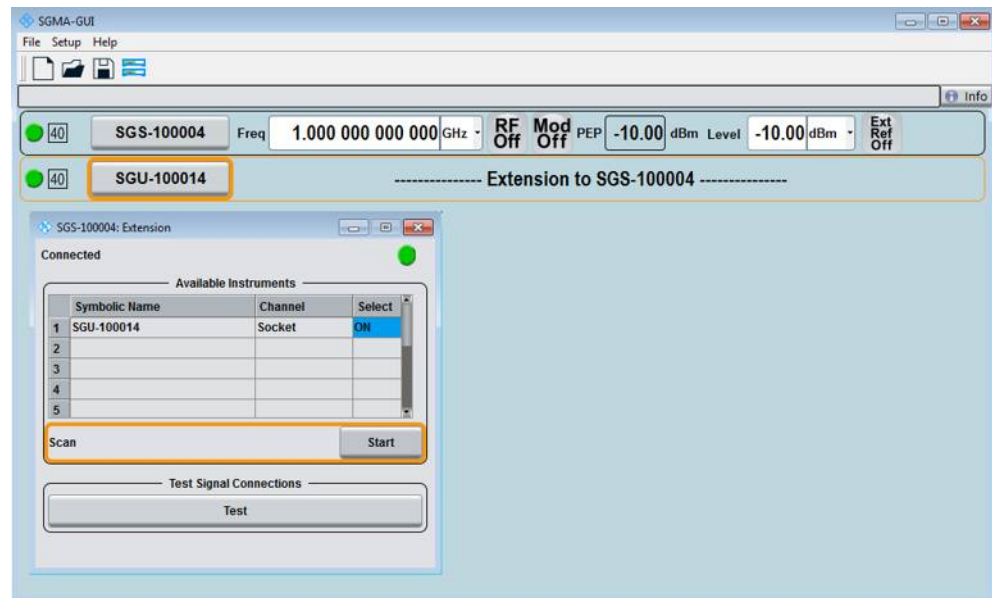

- Select "Test Signal Connections > Test" to trigger a check of all required signal connections.

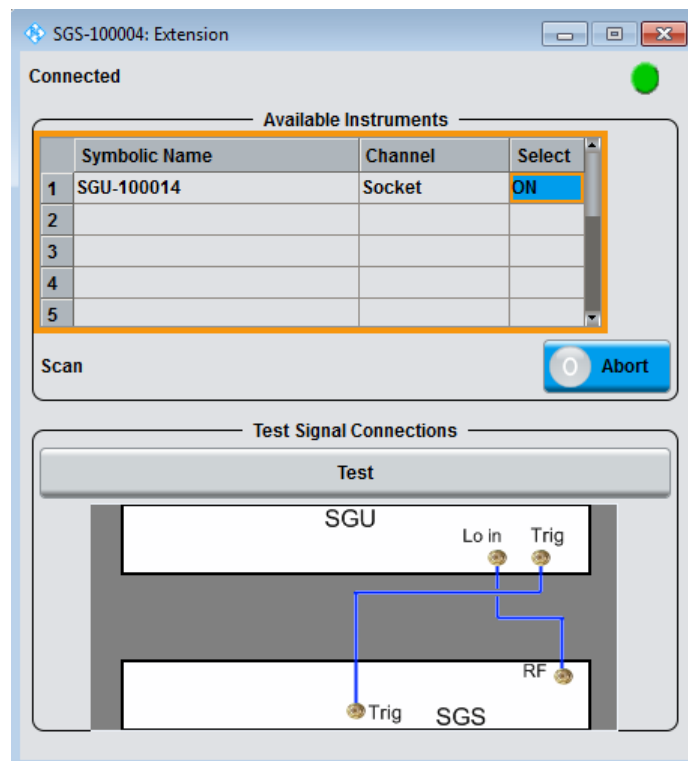

The diagram displays the connection state of the tested connections.

- Select "SGMA-GUI > R&S SGS > Freq = 40 GHz", "Lev = -30 dBm".
- Select "SGMA-GUI > SGS > RF > State > On" to enable the output of the CW signal.

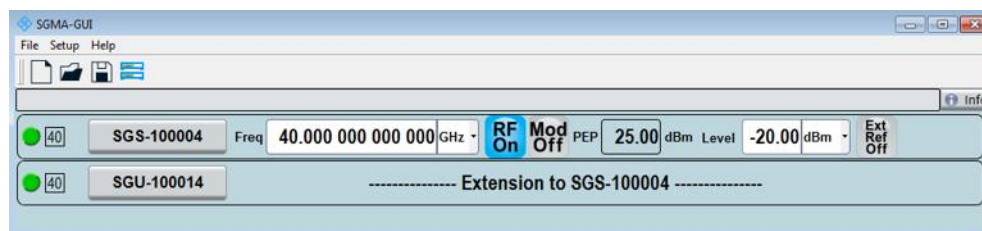

The extension adopts these values and states automatically and generates a CW signal with RF = 40 GHz and Level = -20 dBm.

The signal is output at the [RF OUT] connector on the rear panel of the R&S SGU.



### Identifying a specific instrument

If several instruments are active in the R&S SGMA-GUI use one of the device identification functions to identify a specific device:

- Select "SGMA-GUI > Instrument Name > Setup > Remote > Remote Channels > Device Identify". The green [LAN] LED on the front panel of the instrument blinks.
- Press the [ID] key on the instrument's front panel. The "Edit Instrument" dialog of the respective instrument opens.

## 5.3 Introduction to the Instrument Functions

This section is intended to give a brief introduction to the instrument's function. The description of the related user interface parameters is provided in the corresponding section in [Chapter 7, "Signal Generator Settings"](#), on page 80.

For detailed information on how to work with the instrument and to perform basic and advanced operating and configuration tasks, refer to [Chapter 9, "Performing Configuration Tasks"](#), on page 147.

The [Figure 5-9](#) provides a simplified block diagram of the instrument.

For better understanding of the instrument functions and the signal flow, the block diagram shows the main blocks of the instrument together with the corresponding GUI parameters.

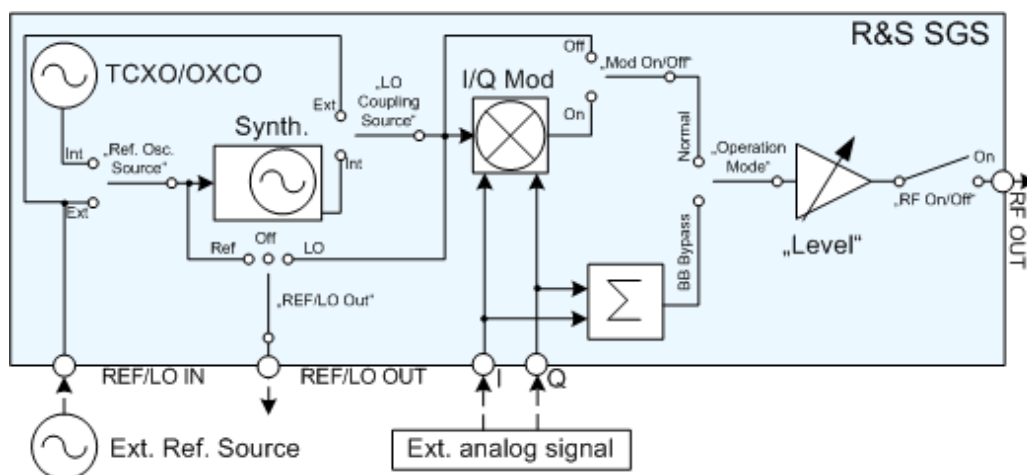

Figure 5-9: Simplified Block Diagram

TCXO	= Built-in reference oscillator
OCXO	= Oven-controlled oscillator, requires hardware option R&S SGS-B1
Synth.	= Synthesizer
I/Q Mod	= I/Q Modulator
REF/LO IN, REF/LO OUT, I, Q, RF OUT	= Connector at the rear panel
"Ref. Osc. Source", "REF/LO Out", "LO Coupling Source", "Mod On/Off", "RF On/Off", "Operation Mode"	= R&S SGMA-GUI equivalent parameter

The instrument can generate a CW or an I/Q modulated signal ("Mod On/Off"). The frequency and level settings are adjustable ("Level", "RF on/Off", "Frequency"). The instrument can use its internal reference frequency or a fed-in external one ([REF/LO IN], "Ref. Osc. Source"). The reference frequency can also be output for synchronization purposes ([REF/LO OUT], "REF/LO Out"). The local oscillator (LO) signal can be distributed in such a way, that two or more instruments are connected to generate phase coherent signals ("LO Coupling Source", [REF/LO OUT], "REF/LO Out"). Whereas both possibilities, the input of the reference frequency and the input of a LO signal, exclude each other because they use the same connectors. The same applies for the output of the reference frequency and the LO signal. The instrument can also be configured to work in the special baseband bypass mode ("Operation Mode").

Refer to [Chapter 9, "Performing Configuration Tasks"](#), on page 147 for an overview of the general operating tasks. The [Chapter 9.1, "How to Generate an I/Q Modulated Signal"](#), on page 147 explains the basic operating concept by means of an example.

## 6 Understanding the R&S SGMA-GUI Software

This section gives a detailed description of the R&S SGMA-GUI user interface and information on how to work with it. The main panel with the overview of the configured instruments is the operating and control interface for the whole program. From here, all program functions are accessible. This panel is displayed after the start of R&S SGMA-GUI. The program always loads the previously used settings so you can continue your work in the next session.

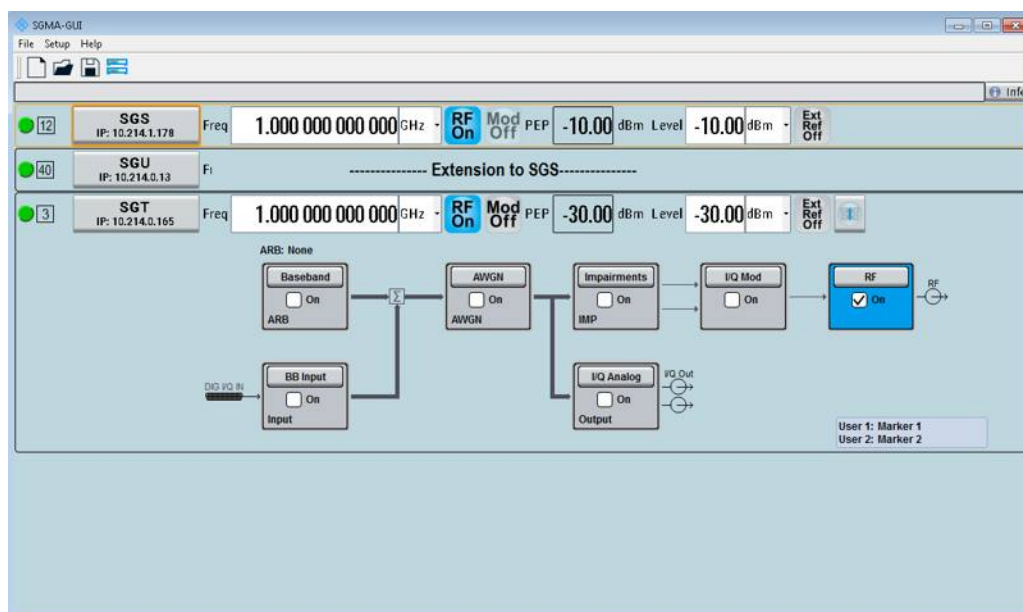

### 6.1 Operating Menu and Toolbar

On the top of the main panel, there are the menu bar, the toolbar and the info bar with the corresponding "Info" button. Some of the functions are accessible via the toolbar with its icons below the menu selection line.

The dialogs are built using elements, e.g., selection lists, checkboxes, and entry fields. A blue frame indicates that the selected item is active. In a highlighted element, entries can be made.

Table 6-1: Content of the operating menu

File	Setup	Help
New	Instruments	About
Open	Software	Contents
Save	Reset SGMA-GUI	Index
Save as	Remote	

File	Setup	Help
Exit	Protection	
Shut down instruments and exit		

### 6.1.1 File Menu

The R&S SGMA-GUI employs the standard Save/Recall file management function and allows you to store and reload settings in/to a file with a user-defined name and location (see also [Chapter 6.4.1, "Storing and Loading Settings"](#), on page 67).

In the following, the "File" menu of the R&S SGMA-GUI is described in detail. It incorporates standard functions.

#### **New**

Resets R&S SGMA-GUI and all connected instruments to their preset settings.

#### **Open**

Opens the standard file open browser for loading a saved R&S SGMA-GUI file (\*.savrc1). The file contains the user-specific settings of a session, such as instruments configured in the software. The complete settings of a session can be saved and loaded.

Only files of this type are selectable.

**Note:** Instrument-specific settings, e.g. frequency and level settings, are stored locally on the particular instrument itself. These instruments settings are saved automatically in a predefined directory and loaded by default when starting the instrument again. The files with instrument settings are not accessible.

#### **Save**

Standard quick save of the settings of the current session if a filename previously has been applied. If not, the "Save As" dialog is opened.

#### **Save as**

Opens the standard file save browser for saving the settings of the current session. R&S SGMA-GUI files have the file extension .savrc1 so the name typed in is equipped with this extension. The complete settings of a session are saved.

#### **Exit**

Quits the R&S SGMA-GUI. The current settings of the instrument's session are saved and loaded by default when starting the software again.

**Note:** The instruments configured in the R&S SGMA-GUI are not shut down.

#### **Shut down instruments and exit**

Quits the R&S SGMA-GUI and switches the connected instruments to the standby state (see also [Chapter 9.9, "How to Switch between the Operating States"](#), on page 156 ).

## 6.1.2 Setup Menu

The setup menu provides access to dialogs for setting the general settings of the software, like dialogs for managing the connected instruments or dialogs providing information about the installed options.

### 6.1.2.1 Configure Instruments

This dialog is the central point for managing the instrument that is configured and operated via the R&S SGMA-GUI. New instruments can be created and appended to the list of available instruments. Connection settings can be edited, instruments can be removed from the list or they can be deactivated, but kept in the list for further use.

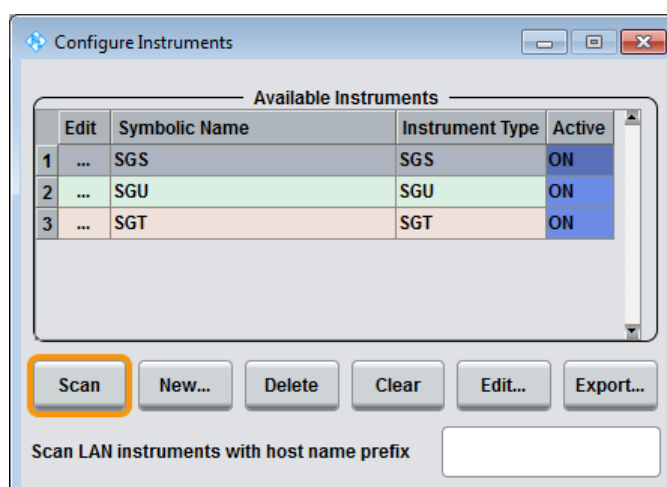

Refer to [Chapter 6.4.2, "Handling Instruments in the R&S SGMA-GUI"](#), on page 68 for information on how to configure and manage instruments in R&S SGMA-GUI.

#### Available Instruments

This section comprises a list of configured instruments. Each instrument is represented by a "Symbolic Name" which is also displayed in the main panel and an "Instrument Type". It is also displayed whether the instrument is activated in the R&S SGMA-GUI and hence displayed in the main panel or not.

Remote command:

`:INSTRUMENTS:COUNT?` on page 76

`:INSTRUMENTS:NAME` on page 77

`:INSTRUMENTS:TYPE` on page 79

`:INSTRUMENTS:ACTIVE[:STATE]` on page 76

#### Scan

Triggers a scan function and searches for instruments connected to the remote computer via all the available interfaces. During the scan process, a progress bar is displayed.

**Tip:** The first initialization of a newly connected instrument in a network and the instrument's request to the DHCP server for an IP address may take some time. During this time, the instrument does not respond to the query sent by the scan function. If the instrument does not appear in the list of "Available Instruments", trigger the scan function again after some minutes.

Remote command:

:INSTRUMENTS:SCAN on page 78

### New Instrument

Calls the [Add/Edit Instruments](#) dialog.

### Delete Instrument

Removes the selected instrument from the list of [Available Instruments](#).

### Edit Instrument

Calls the [Add/Edit Instruments](#) dialog.

### Clear Instrument

Removes all instruments from the list of [Available Instruments](#).

### Export

Opens the standard file save browser for saving the list of the available instruments in a mapping file. The mapping files have the file extension `.map` so the filename typed in is automatically equipped with this extension.

A mapping file provides a cross-reference between the instruments' symbolic names and their respective remote control parameters. The information in the mapping file is grouped in rows, where one row corresponds to one configured instrument. The rows have the following structure:

```
<InstrumentType> <SymbolicName> <IP_Address/Hostname>
<RemoteChannel> <SerialNumber>
```

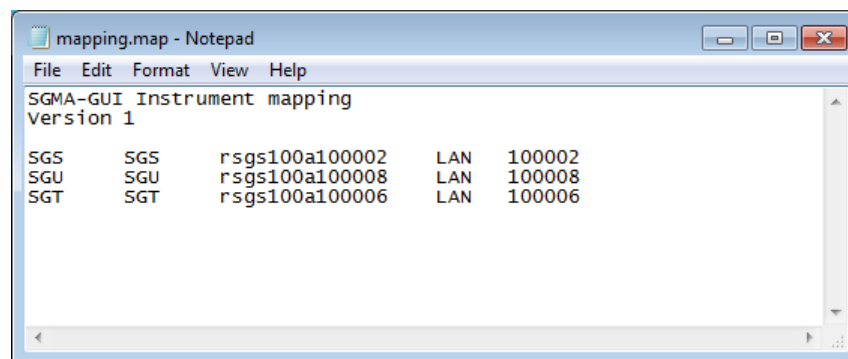

*Figure 6-1: Mapping file example*

**Tip:** In a remote control application program, address the instruments by their symbolic names and retrieve the remain required settings from the mapping file. This workflow is especially useful for frequent exchange of instruments.

Remote command:

:INSTRUMENTS:MAPPING:FILE on page 77

**Scan LAN instruments with host name prefix**

Sets the prefix the searched host names begin with. Use this function to limit the amount of the searched instruments and to speed up the scan process.

For example, set this field to "RsSGS, RsSGU, RsSGT", if you want to search for all available instruments.

**Tip:** If you start a scan for an instrument with a set IP address and it does not appear in the list of available instruments it may be due to the prefixes written in this field. You can perform another scan while leaving this field empty.

Remote command:

:INSTRUMENTS:SCAN:HNPRefix on page 78

**6.1.2.2 Add/Edit Instruments**

The dialog provides access to the main instrument's settings, such as "Symbolic Name", "Instrument Type" and connection settings.

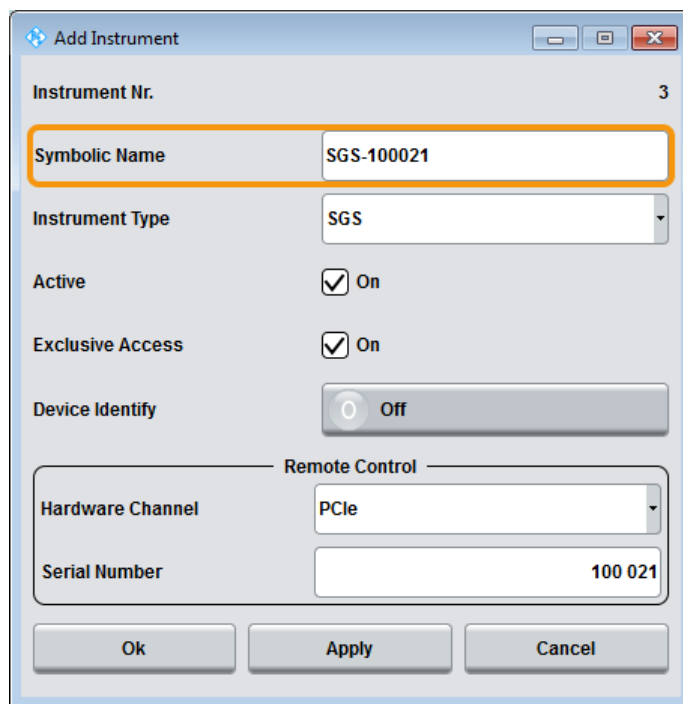

Refer to [Chapter 6.4.2, "Handling Instruments in the R&S SGMA-GUI"](#), on page 68 for information on how to configure and manage instruments in R&S SGMA-GUI.

**Instrument Nr.**

Automatically assigned number that indicates the instrument's index in the list of "Available Instruments".

**Symbolic Name**

Selects the alias name of the instrument.

Remote command:

`:INSTRUMENTS:NAME` on page 77

### Instrument Type

Selects the instrument's family.

Remote command:

`:INSTRUMENTS:TYPE` on page 79

### Active

Activates/deactivates the display of the instrument's settings in the main panel.

**Note:** Only instruments in an active state can be controlled from the R&S SGMA-GUI!

Remote command:

`:INSTRUMENTS:ACTIVE[:STATE]` on page 76

### Exclusive Access

Checks whether the instrument is locked by another user and if not locks the instrument. When an instrument is locked, it is reserved and can be operated manually or remote **exclusively** from the remote PC on which the R&S SGMA-GUI is running or from which the SCPI command is sent.

For interfaces using VISA, i.e. for LAN and USB, enabling the "Exclusive Access" triggers the standard `viLock` request. For remote control over PCIe or Socket, the lock request is performed on a higher application level.

**Note:** It is recommended to lock the instrument before further configuration.

Locked instruments are not found by the scan function.

The instrument has to be unlocked to allow operation from another remote PC.

**Note:** The two functions "Exclusive Access" and monitoring are mutually exclusive.

Disable "Exclusive Access" if the instrument is monitored by an external PC.

Remote command:

`:INSTRUMENTS:EACCESS[:STATE]` on page 76

`:LOCK?` on page 203

`:UNLOCK` on page 204

### Device Identity

Triggers the device identification function. The [LAN] LED on the front panel of the selected instrument blinks.

See also [Chapter 6.4.4, "Bidirectional Instrument Identification"](#), on page 71.

### Hardware Channel

Selects the hardware interface used by the remote channel.

Remote command:

`:INSTRUMENTS:REMOTEC:CHANNEL` on page 77

### Instrument Name / IP Address

Enters the IP address or the host name of the connected instrument.

See also [Chapter 6.4.3, "Finding Out the Default Hostname of the Instrument"](#), on page 71.

Remote command:

`:INSTruments:REMOte:NAME` on page 77

#### **GPIB Address**

Enters the GPIB address of the connected instrument.

See also [Chapter 10.1.5, "GPIB Interface \(IEC/IEEE Bus Interface\)"](#), on page 170.

Remote command:

`:INSTruments:GPIB:ADDReSS` on page 78

#### **Board Number**

Identifies the GPIB bus card of the controller to that the adapter is connected.

See also [Chapter 10.1.5, "GPIB Interface \(IEC/IEEE Bus Interface\)"](#), on page 170.

Remote command:

`:INSTruments:GPIB:BOARd` on page 78

#### **Serial Number**

Enters the serial number as instrument's identification while using the USB or PCIe interfaces for remote control.

Remote command:

`:INSTruments:SERial` on page 78

#### **OK**

Confirms the settings and closes the dialog.

#### **Apply**

Confirms the settings.

#### **Cancel**

Discards settings and closes the dialog.

### **6.1.2.3 Versions/Options Dialog**

#### **Querying information about the installed options and software version**

- ▶ Select "Setup > Software".

An info dialog opens, showing program information.

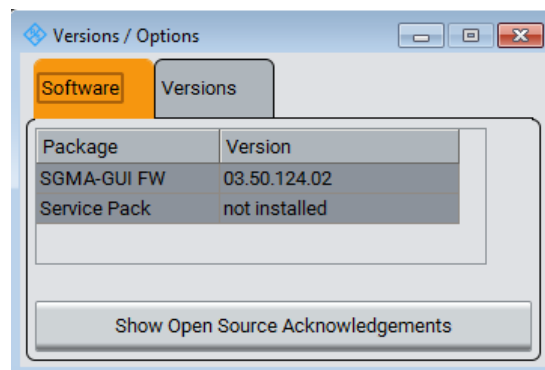

### Software

Displays information on:

- "Package"        Installed software packages.
- "Version"        Release of the software package.

### Show Open Source Acknowledgments

Accesses the list of the used open source software packages and the corresponding verbatim license texts.

### Versions

Shows the installed software platform and its version.

#### 6.1.2.4 Protection

The "Protection" dialog provides access to the unlocking of protected service functions (authorized personnel of Rohde & Schwarz service departments only).

#### Unlocking of protected service functions

1. Select "SGMA-GUI > Setups > Protection".  
After the instrument has been switched on, the protection levels 1 to 4 are automatically activated.
2. To deactivate the protection, enter the correct password.  
Enter "Protection Level 1 > Password > 123456".  
Protection Level 1 is activated.

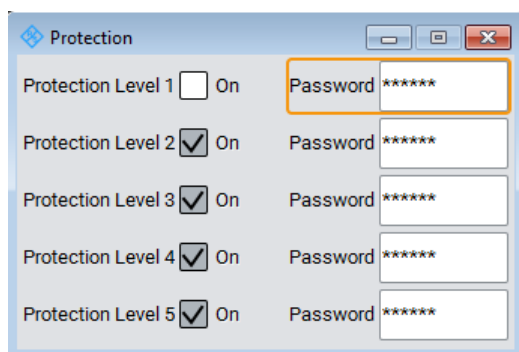

### Protection Level / Password

"Protection Level 1" can be activated to expand the functionality of the internal adjustment. The password is 123456.

The other protection levels 2 to 4 provide access to protected service functions. Only the authorized personnel of Rohde & Schwarz service departments can access these functions.

#### 6.1.2.5 Reset SGMA-GUI

Resets R&S SGMA-GUI to its factory preset settings.



The connected instruments are not affected by this preset.

To preset one specific instrument to its factory preset settings, select "SGMA-GUI > Instrument Name > Setup > Factory Preset". Refer to [Chapter 8.11, "Factory Preset"](#), on page 142 for an overview of the settings affected by this function.

#### 6.1.2.6 Remote

Access: "SGMA-GUI > Setup > Remote".

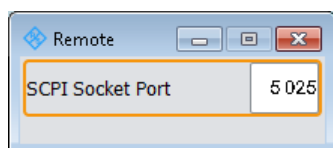

### SCPI Port

Sets the port number of the LAN interface for remote control with TCP/IP socket protocol.

This allows you to set different port numbers if you want to control different software, e.g. R&S SGMA-GUI and R&S WinIQSIM2, from the same application.

Remote command:

:SYSTEM:COMMunicate:SOCKet:PORT on page 273

### 6.1.3 Help

The R&S SGMA-GUI is equipped with a context-sensitive help function. A help page can be called any time during software operation.

The context-sensitive page which is opened with the [F1] button is part of a comprehensive help system.

It is possible to move from this context-sensitive page to any page of the help system. An overview of the contents of the online help can be reached via the menu "SGMA-GUI > Help > Contents".

A search for keywords within the help function is available via menu item "SGMA-GUI > Help > Index".

## 6.2 Info Dialog and Messages in the Info Bar

A few operating states and the current messages are displayed in the info line. For information on messages in greater detail and their management, an "Info" dialog can be opened.

### 6.2.1 Info Dialog

The "Info" dialog provides a list of currently active permanent messages and a detailed description of each message. The messages are color-coded according to their level.

#### Accessing the info dialog

- ▶ In the "R&S SGMA-GUI main panel", select the "Info" button.

The "Info" dialog opens.

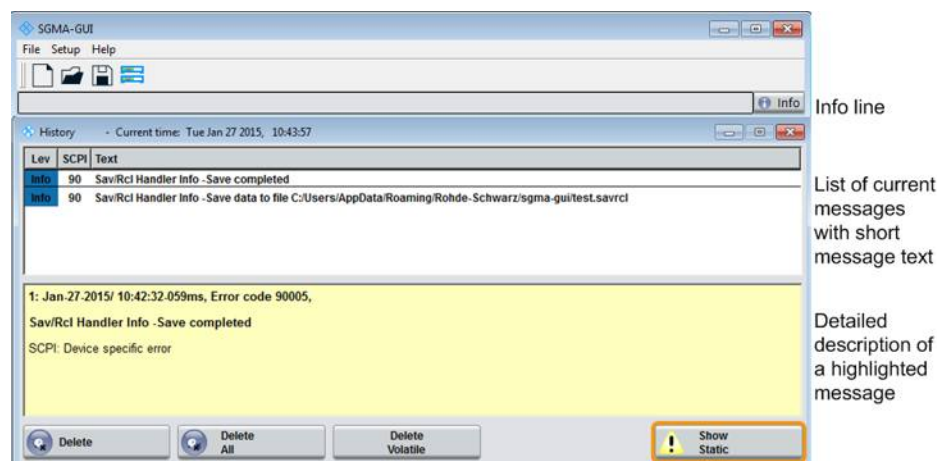

The upper part of the "Info" dialog lists the currently active permanent messages. See the following table for explanation of the displayed information.

Parameter	Description
"LEV"	<p>Message level. Messages referring to a logical component of R&amp;S SGMA-GUI, e.g., Unicode, are marked in red color, info messages are marked in black color.</p> <p>The following levels might occur:</p> <ul style="list-style-type: none"> <li>• Err: Error message</li> <li>• Info: Information message</li> <li>• Sys: System message</li> <li>• Crit: Critical message</li> </ul> <p>For detailed information on the message types, see <a href="#">Chapter 6.2.2, "Understanding the Messages in the Info Bar"</a>, on page 63.</p>
"SCPI"	Indicates the SCPI error code.
Text	A list of all currently permanent messages in the order of their occurrence, i.e., the most recent message is displayed first.

The buttons in the lower part of the "Info" dialog provide quick access to some functions for managing these messages. For a detailed description on how to clear error messages or display a history of all messages, refer to [Chapter 6.4.5, "Managing Messages in the Info Dialog"](#), on page 73.

Function	Description
"Delete"	Clears the highlighted message. This button is available only if the history of the messages is displayed.
"Delete All"	Clears all messages. This button is available only if the history of the messages is displayed.
"Del. volatile"	Clears all brief messages. This button is available only if the history of the messages is displayed.
"Show History/Static"	Calls the list of all messages that have occurred since instrument switch-on. The most recent messages are displayed at the top of the list. When the button is pressed again, the list of current messages is displayed.



Refer to [Chapter 6.4.5, "Managing Messages in the Info Dialog"](#), on page 73 for information on how to manage messages.

## 6.2.2 Understanding the Messages in the Info Bar

Messages indicate information, warnings, and errors. They are displayed in the info line in different colors depending on their importance and display duration. The following messages are displayed:

- Error
  - There are two options:
    - Critical errors are errors that prevent the instrument from working, e.g. an HW failure. Critical errors are displayed in red color.
    - System errors are errors that concern the operating system, e.g., wrong file path. System errors are displayed in black color.
- Information

The information, e.g., file not found, is displayed in black color.

- **Warning**  
A warning indicates a less significant error and is displayed in black color.
- **Brief message**  
Brief messages report automatic settings in the program, e.g. switching on illegal entries that are not accepted by the program, e.g., range violations. They are displayed in the info line on a yellow background. They are displayed on top of status information or permanent messages.  
Brief messages usually do not demand user actions and disappear automatically after a short period of time. They are stored in the history, however.
- **Permanent messages**  
Permanent messages are displayed if an error occurs that impairs further program operation. The error signaled by a permanent message must be eliminated before correct software operation can be ensured.  
The message is displayed until the error is eliminated. It covers the status display in the info line. After error elimination, the message automatically disappears and is also recorded in the history.

### 6.3 Main Panel

The main panel of the R&S SGMA-GUI provides quick access to the main settings of the configured instruments. The display shows one row per instrument and comprises the instrument name and state, the used frequency and power level, the states of the RF output and modulator and the used reference source.

Click one of the buttons with an instrument name on it to access the menu tree with further settings for the corresponding instrument. For a detailed description of the provided settings, see:

- [Chapter 8, "General Instrument Settings and Instrument Setup"](#), on page 128 for general settings
- [Chapter 7, "Signal Generator Settings"](#), on page 80 for R&S SGS settings.

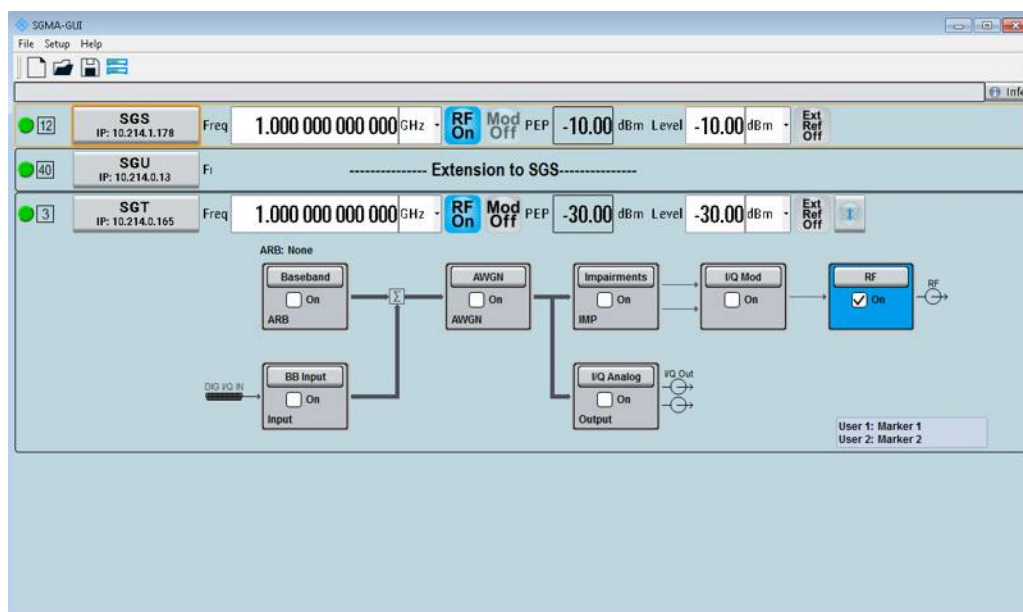

### Instrument/Connection State

The three colors of the state indicator in front of the instrument's name distinguish between the following states:

- Gray: the instrument is configured and activated in the R&S SGMA-GUI but there is no connection to the instrument.
- Green: the instrument is active, the connection is working and the instrument can be manually and remotely operated.
- Red: the instrument is in one of the following states:
  - Standby state  
To operate the instrument manually, it has to be switched to ready state (see ["To return the instrument from standby to ready state"](#) on page 157).
  - Instrument locked  
The red state indication together with the message "Instrument Locked" in the "Info" line indicates that the instrument is locked for [Exclusive Access](#) from another SGMA-GUI or controller.
  - The instrument is performing a time consuming operation, e.g. a selftest.

### Maximum Frequency

The numbers in the rectangular box  on the left of the instrument's name indicate the maximum frequency of the instrument.

When the [Eco Mode](#) is turned on then this rectangular is colored in green and the frequency shown in the rectangular corresponds to the maximum frequency available in this mode.

### Pulse Modulation

A  sign on the left of the instrument's name indicates that the pulse modulation is switched on.

**Instrument Name/ IP Address**

Displays the alias name of the instrument and the IP address, as set by the parameters in "SGMA-GUI > Setup > Instruments > Add/Edit Instruments" dialog.

Click the button to access a menu tree for configuring the available instrument's settings, e.g. "Level" settings.

Freq  
(Offs)

**Freq/Freq (Offs)**

Sets the RF frequency, incl. enabled frequency offset.

The following applies:

"Freq" = **Frequency** + **Offset**

Where, the value set with the parameter "SGMA-GUI main panel > instrument name > Frequency/Phase > Frequency" is the RF frequency at the RF output, without the frequency offset.

The icon "Freq (Offs)" indicates that a frequency offset is applied.

Remote command:

`[ :SOURce ] :FREQuency [ :CW | FIXed ]` on page 236

RF  
On

**RF On/Off**

Activates and deactivates the RF output signal.

The current state of the RF output (activated and deactivated) is indicated in the main panel with the different block color (blue or gray) and the status "On/Off".

Remote command:

`:OUTPut [ :STATe ]` on page 223

Mod  
On

**Mod State**

Switches the I/Q modulation on and off.

Remote command:

`[ :SOURce ] :IQ:STATe` on page 246

**PEP**

Displays the Peak Envelope Power (PEP) of the RF signal of the selected instrument. The value is calculated as follows:

"PEP" = Level + **Crest Factor**

Remote command:

`[ :SOURce ] :POWer :PEP?` on page 252

**Level/Level Offset**

Sets the RF level at the RF output connector of the selected instrument.

If you set a level offset, it will be indicated in the R&S SGMA-GUI main panel by a change in the name of this parameter from "Level" to "Level Offset".

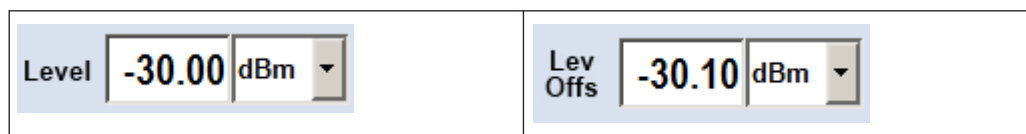

**Note:** The SCPI command `[ :SOURce ] :POWer [ :LEVel ] [ :IMMediate ] [ :AMPLitude ]` sets the level of the "Level" display, that means the level containing offset while `[ :SOURce ] :POWer :POWer` sets the level at the RF output connector.

Remote command:

`[ :SOURce ] :POWer [ :LEVel ] [ :IMMediate ] [ :AMPLitude ]` on page 251  
`[ :SOURce ] :POWer :POWer` on page 250



#### Ref. Oscillator Source/Ext Ref On/Off

Determines whether the internal built-in oscillator (TXCO or OXCO) is used as a reference source or if an external reference is used. The internal reference oscillator OXCO requires the additional option R&S SGS-B1.

To feed in an external instrument reference, use the input connector [REF/LO IN]. To output the reference frequency at the output [REF/LO OUT], select "SGMA-GUI > Instrument Name > Ref. Oscillator > REF/LO Output > REF".

See also [Chapter 9.4, "How to Configure the Reference Oscillator Source"](#), on page 152.

"Int"                    The internal reference signal of 10 MHz is used.

"Ext"                    An external reference signal is used. The frequency of the external reference signal must be selected with the parameter "SGMA-GUI > Instrument Name > Ref. Oscillator > Ex. Ref. Input Frequency".

Remote command:

`[ :SOURce ] :ROSCillator :SOURce` on page 260



#### LO Src Ext

This icon indicates that the internal local oscillator is switched off.

See ["Source"](#) on page 83.

## 6.4 Working with R&S SGMA-GUI

This section explains how to work with the R&S SGMA-GUI software and perform configuration tasks for manual operation of the instruments.

### 6.4.1 Storing and Loading Settings

To proceed work with a particular configuration of the instruments in the R&S SGMA-GUI, it is useful to save the used settings and load them again later.

#### How to store and load settings

1. Select "SGMA-GUI main panel > File > Save As".
2. Navigate to the desired directory and enter the filename.  
The extension `*.savrc1` is applied automatically.  
The current settings of the software are saved to the selected file.

3. To load settings from a file, select "SGMA-GUI main panel > File > Open"
4. Navigate to the directory the file is stored in and select the setting file.  
The saved settings are loaded to the R&S SGMA-GUI and the main panel of the software displays the saved instrument's configuration.

## 6.4.2 Handling Instruments in the R&S SGMA-GUI

This section provides information on how to configure and manage instruments in the R&S SGMA-GUI.

For reference information about all provided settings in the user interface, refer to the corresponding sections:

- [Chapter 6.1.2.1, "Configure Instruments"](#), on page 55 and [Chapter 6.1.2.2, "Add/Edit Instruments"](#), on page 57
- [Chapter 6.1.2.3, "Versions/Options Dialog"](#), on page 59  
[Chapter 6.1.2.5, "Reset SGMA-GUI"](#), on page 61

### 6.4.2.1 How to Automatically Add New Instruments to the SGMA-GUI

1. For each new instrument perform the following steps:
  - a) Connect the instrument to the network.
  - b) Switch on the instrument.
  - c) Press the [ID] key on the front panel of the instrument.
2. Start the SGMA-GUI on a computer connected to the same network.  
All instruments are added automatically to the main panel of the SGMA-GUI.

### 6.4.2.2 How to Manually Add New Instruments to the SGMA-GUI

1. In the R&S SGMA-GUI main panel, select "Setup > Instruments".  
The [Configure Instruments](#) dialog opens.
2. Select the "New" button.  
The [Add Instrument](#) dialog opens to register a new instrument.
3. In the "Symbolic Name" field, enter an alias name of your choice, e.g. SGS-100021.
4. In the "Instrument Type" field, select the device family to connect to.
5. Select "Remote Control > Hardware Channel" and select the hardware interface.
6. For LAN or Socket interfaces, select "Remote Control > Instrument Name / IP Address" and enter the IP Address or the hostname of the connected instrument, e.g. rssgs100a100021.

**Tip:** See also [Chapter 6.4.3, "Finding Out the Default Hostname of the Instrument"](#), on page 71 .

7. For USB or PCIe interfaces, select "Remote Control > Serial Number" and enter the serial number of the connected instrument , e.g. 100021.
8. Set "Active > On" to activate the instrument. Only active instruments are displayed in the R&S SGMA-GUI main panel.
9. Click "OK" to confirm the settings and to close the dialog or press the "Apply" button to confirm the settings.
10. Click the "Cancel" button to discard settings and to close the dialog.

#### 6.4.2.3 How to Scan for New Instruments

1. In the R&S SGMA-GUI main panel, select "Setup > Instruments".  
The [Configure Instruments](#) dialog opens.
2. Click the "Scan" button to trigger the instrument to scan all remote channel interfaces for connected instruments.

**Tip:** To limit the amount of the searched instruments and to speed up the scan process, select "Configure Instruments > Scan LAN instruments with hostname prefix" and enter the prefix the searched hostnames begin with.  
The scan function searches only for instruments whose hostnames begin with the selected prefix.

All instruments which are connected to one of the available interfaces, are switched on and are not locked are displayed in the "Available Instruments" list. The R&S SGMA-GUI obtains all information for connecting to the instrument, so further configuration is not necessary.

#### 6.4.2.4 How to Activate Instruments for Control from the R&S SGMA-GUI

1. In the R&S SGMA-GUI main panel, select "Setup > Instruments".  
The "Available Instruments" in the [Configure Instruments](#) dialog lists all instruments configured in the software.
2. Select the newly configured/connected or deactivated instrument and set "Active > On" to activate it.

**Tip:** Only active instruments are displayed in the R&S SGMA-GUI main panel!

#### 6.4.2.5 How to Edit Instruments

1. In the R&S SGMA-GUI main panel, select "Setup > Instruments".  
The [Configure Instruments](#) dialog opens and lists the "Available Instruments".

2. Select the instrument to be edited and click the "Edit" button.  
The [Edit Instrument](#) dialog opens.
3. Change the settings and confirm with OK.  
The edited settings are applied.

#### 6.4.2.6 How to Delete an Instrument

1. In the R&S SGMA-GUI main panel, select "Setup > Instruments".  
The [Configure Instruments](#) dialog opens.
2. Select the instrument to be deleted and click the "Delete" button.  
The selected instrument is deleted from the list of "Available Instruments".

#### 6.4.2.7 How to Delete All Instruments

1. In the R&S SGMA-GUI main panel, select "Setup > Instruments".  
The [Configure Instruments](#) dialog opens.
2. Click the "Clear" button.  
All instruments are deleted from the list of "Available Instruments".

#### 6.4.2.8 How to Reserve the Instrument for Control

1. Open the "SGMA-GUI > Setup > Instruments > Configure Instruments" dialog, select the instrument in the list of "Available Instruments" and select "Edit".
2. In the "Edit Instrument" dialog, enable "Exclusive Access".
3. Alternatively, send the SCPI command `:INSTruments:EACcEss[:STATe]` from the external PC the R&S SGMA-GUI is installed on.

The instrument is reserved for control from this external PC and cannot be accessed from any other controller. A scan function started from another controller finds the instrument but the instrument is indicated as locked.



The two functions "Exclusive Access" and monitoring are mutually exclusive!  
The "Exclusive Access" must be disabled to remote control or monitor the instrument from another external PC (see [Chapter 10.6, "Using the R&S SGMA-GUI to Monitor the Remote Control Operation"](#), on page 187).

---

### 6.4.3 Finding Out the Default Hostname of the Instrument

The default hostname of the instrument is a non-case-sensitive string built as follows:

hostname = <instrument name><serial number>, where

<serial number> is the individual serial number of the instrument

<instrument name> is the complete name of the instrument, written without spaces.

#### How to query the hostname of the instrument

1. Find the individual serial number on rear of the instrument , e.g. 100021.
2. Build the default hostname.

For the R&S SGS with serial number 100021, the default hostname is  
rssgs100a100021.



For instructions on how to change the default hostname, refer to [Chapter 9.10, "How to Use Computer Names"](#), on page 158.

---

### 6.4.4 Bidirectional Instrument Identification

In practice, instruments are integrated into a large network or placed in racks together with several other instruments of the same kind. It might be difficult then to find out which of the instruments configured in the R&S SGMA-GUI corresponds to which physical instrument or to localize all instruments operated by the current controller.

The R&S SGMA-GUI and the instrument provide the "Device Identification" function for this purpose.

#### How to find an instrument in the R&S SGMA-GUI

- ▶ If several instruments have been configured and activated in the R&S SGMA-GUI, press the [ID] button on the instrument's front panel to trigger device identification.

The "Edit Instrument" dialog of this instrument opens.

Field "Edit Instrument > Symbolic Name" displays the name of the instrument as shown in the R&S SGMA-GUI main panel.



### Dialog "Edit Instrument" does not appear

If this dialog does not open, perform the following:

- Check whether the instrument is correctly connected to the external PC on which you work with the R&S SGMA-GUI.
- Check if the instrument is configured in the R&S SGMA-GUI and perform, if necessary, the steps described in [Chapter 6.4.2, "Handling Instruments in the R&S SGMA-GUI"](#), on page 68.
- Select "SGMA-GUI > Setup > Instruments", check the state of the instrument in the "Configure Instruments > Available Instruments" table and activate it, if disabled.

Edit	Symbolic Name	Instrument Type	Active
1 ...	SGS	SGS	ON
2 ...	SGU	SGU	ON
3 ...	SGT	SGT	ON

### How to identify an instrument in an instrument set

- ▶ To identify the instrument in an instrument set, use one of the device identification functions:
  - a) Select "SGMA-GUI > Setup > Instruments > Available Instruments > Instrument > Edit > Edit Instrument" and trigger "Device Identify"
  - b) Select "SGMA-GUI > Instrument Name > Setup > Remote > Remote Channels" and trigger "Device Identify"

The green [LAN] LED on the front panel of the instrument blinks.

## 6.4.5 Managing Messages in the Info Dialog

### How to get additional information on the message

- ▶ In the "Info" dialog, click a message to select it.

In the lower section of the dialog, additional information on the highlighted message is displayed.

### How to display all messages

- ▶ In the "Info" dialog, click the "History" button.

A history of all messages that have occurred since the R&S SGMA-GUI software was started is listed in the upper dialog pane. The most recent message is displayed first.

### How to delete an error message

- ▶ In the "Info" dialog, select the highlighted message and click the "Delete" button.

**Tip:** This button is available only when the history of the messages is displayed.

The highlighted message is cleared.

### How to delete all error messages

- ▶ In the "Info" dialog, click the "Delete All" button.

**Tip:** This button is available only when the history of the messages is displayed.

All messages are cleared.

### How to delete all brief messages

- ▶ In the "Info" dialog, click the "Del. volatile" button.

**Tip:** This button is available only when the history of the messages is displayed.

All brief messages are cleared.

**How to call the history**

1. In the "Info" dialog, click the "History" button.  
A list of all messages that have occurred since the instrument switch-on is displayed. The most recent messages are displayed at the top of the list.
2. Click the "History" button once more.  
A list of current messages is displayed.

## 6.5 Remote Control of the R&S SGMA-GUI

This section focuses on the remote control of the R&S SGMA-GUI software.

### 6.5.1 Configuring Instruments in the R&S SGMA-GUI

This section provides an example of the automation of the R&S SGMA-GUI.

In the following example we assume that a remote PC with installed R&S SGMA-GUI on it is connected to a LAN and that the remote PC and the instruments are switched on.

For more information, refer to [Chapter 2.3, "Connecting an External PC and Devices"](#), on page 22.

```
// *****
// Trigger the scan function to search for instruments connected
// to the remote computer via all of the available interfaces.
// *****

:INSTRUMENTS:SCAN:HNPREFIX "rsg"
// scan returns only instruments with hostname beginning with "rsg"
:INSTRUMENTS:SCAN 1
*OPC?

// *****
// Query the number of available instruments and the settings of each
// configured instrument: instrument type, symbolic name,
// remote channel used, serial number, hostname/IP address
// Adjust settings if required
// *****

:INSTRUMENTS:COUNT?
// Response: 3

:INSTRUMENTS:TYPE?
// Response: SGU,SGS,SGT

:INSTRUMENTS:NAME?
```

```
// Response: SGU-100002,SGS-100006, SGT-100008

:INSTRUMENTS:SERIAL?
// Response: 100002,100006,100008

:INSTRUMENTS:REMOTE:CHANNEL?
// Response: LAN,USB, PCIE

:INSTRUMENTS:REMOTE:NAME?
// Response: rsgsu100a100002, rsgsg100a100006, rsgst100a100008

// *****
// Check the instrument state and activate instruments if required
// *****

:INSTRUMENTS:ACTIVE:STATE?
// Response: 0,1,1
:INSTRUMENTS:ACTIVE:STATE ON,OFF,OFF
// Activates the first instruments in the list,
// i.e. the instruments with symbolic names SGS-100006

// *****
// Export the configuration into a mapping file
// *****

:INSTRUMENTS:MAPPING:FILE 'd:\mapping_files\mapping.map'

// *****
// Enable exclusive access for the selected instrument
// *****

:INSTRUMENTS:EACCESS:STATE?
// Response: 0,0,0
:INSTRUMENTS:EACCESS:STATE ON,OFF, OFF
// Locks the first instrument
```

### 6.5.2 R&S SGMA-GUI Settings

This section comprises the SCPI commands provided to remote control the R&S SGMA-GUI.

:INSTRUMENTS:ACTIVE[:STATE]	76
:INSTRUMENTS:COUNT?	76
:INSTRUMENTS:EACCESS[:STATE]	76
:INSTRUMENTS:MAPPING:FILE	77
:INSTRUMENTS:NAME	77
:INSTRUMENTS:REMOTE:CHANNEL	77
:INSTRUMENTS:REMOTE:NAME	77
:INSTRUMENTS:GPIB:ADDRESS	78

:INSTruments:GPIB:BOARD.....	78
:INSTruments:SCAN.....	78
:INSTruments:SCAN:HNPRefix.....	78
:INSTruments:SERial.....	78
:INSTruments:TYPE.....	79

---

#### :INSTruments:ACTive[::STATe] <State>

Enables/disables the instrument for the R&S SGMA-GUI. The main panel of this software displays only activated instruments.

##### Parameters:

<State>                   List of BOOL-values  
                               <StateInstr#1>,<StateInstr#2>,...  
                               0, 1, ON, OFF

**Example:**                See [Chapter 6.5.1, "Configuring Instruments in the R&S SGMA-GUI"](#), on page 74.

**Manual operation:**    See ["Available Instruments"](#) on page 55

---

#### :INSTruments:COUNT?

Queries the number of the currently available instruments.

##### Return values:

<Count>                   float  
                               Range:     0 to 12

**Example:**                See [Chapter 6.5.1, "Configuring Instruments in the R&S SGMA-GUI"](#), on page 74.

**Usage:**                   Query only

**Manual operation:**    See ["Available Instruments"](#) on page 55

---

#### :INSTruments:EACCess[::STATe] <State>

"Locks" the instruments, meaning the instrument is reserved and can be operated exclusively from the remote PC that sent this SCPI command.

**Tip:** It is recommended to lock the instrument prior to further configuration.

##### Parameters:

<State>                   List of BOOL-values  
                               <LockInstr#1>,<LockInstr#2>,...  
                               0,1,OFF,ON

**Example:**                See [Chapter 6.5.1, "Configuring Instruments in the R&S SGMA-GUI"](#), on page 74.

**Manual operation:**    See ["Exclusive Access"](#) on page 58

---

**:INSTruments:MAPPing:FILE** <File>

Saves the list of the available instruments in a mapping file. Mapping files are stored with the predefined file extension `.map`; the file extension may be omitted.

The file is saved in the default directory. Use the command `MMEM:CDIRectory` to change the default directory or specify the complete path.

**Parameters:**

<File> string

**Example:** See [Chapter 6.5.1, "Configuring Instruments in the R&S SGMA-GUI"](#), on page 74.

**Manual operation:** See ["Export"](#) on page 56

---

**:INSTruments:NAME** <Name>

Selects the alias name of the instruments, i.e. sets the "Symbolic Name".

**Parameters:**

<Name> <SymbolicNameInstr#1>,<SymbolicNameInstr#2>,...

**Example:** See [Chapter 6.5.1, "Configuring Instruments in the R&S SGMA-GUI"](#), on page 74.

**Manual operation:** See ["Available Instruments"](#) on page 55

---

**:INSTruments:REMOte:CHANnel** <Channel>

Sets the hardware interface used by the remote channel.

**Parameters:**

<Channel> List of CHAR-Data  
<ChannellInstr#1>,<ChannellInstr#2>,...  
The available interfaces are: LAN, USB, SOCKET, PCIe, GPIB, HiSLIP

**Example:** See [Chapter 6.5.1, "Configuring Instruments in the R&S SGMA-GUI"](#), on page 74.

**Manual operation:** See ["Hardware Channel"](#) on page 58

---

**:INSTruments:REMOte:NAME** <Name>

Enters the IP Address or the host name of the connected instrument.

**Parameters:**

<Name> <Hostname/IP-AddressInsr#1>,<Hostname/IP-AddressInsr#2>,...

**Example:** See [Chapter 6.5.1, "Configuring Instruments in the R&S SGMA-GUI"](#), on page 74.

**Manual operation:** See ["Instrument Name / IP Address"](#) on page 58

---

**:INSTruments:GPIB:ADDRess** <Serial>

Sets the GPIB Address of the connected instrument.

**Parameters:**

<Serial>                    List of Numbers

**Manual operation:**    See "[GPIB Address](#)" on page 59

---

**:INSTruments:GPIB:BOARd** <Board>

Identifies the GPIB bus card the controller uses.

**Parameters:**

<Board>                    List of Numbers

**Manual operation:**    See "[Board Number](#)" on page 59

---

**:INSTruments:SCAN** <State>

Triggers a scan function and searches for instruments connected to the remote computer via all of the available interfaces.

**Parameters:**

<State>                    number

1 = triggers the scan function, 0 = aborts the running scan process

The query command returns 1 as long as scan is running; 0 indicates completed scan process.

**Example:**                See [Chapter 6.5.1, "Configuring Instruments in the R&S SGMA-GUI"](#), on page 74.

**Manual operation:**    See "[Scan](#)" on page 55

---

**:INSTruments:SCAN:HNPRefix** <Prefix>

Sets the prefix the searched host names begin with.

**Parameters:**

<Prefix>                    string

**Example:**                See [Chapter 6.5.1, "Configuring Instruments in the R&S SGMA-GUI"](#), on page 74.

**Manual operation:**    See "[Scan LAN instruments with host name prefix](#)" on page 57

---

**:INSTruments:SERial** <Serial>

Enters the serial number as instrument's identification while using the USB interface for remote control.

**Parameters:**

<Serial> <SerialNumberInstr#1>, <SerialNumberInstr#2>,...

**Example:**

See [Chapter 6.5.1, "Configuring Instruments in the R&S SGMA-GUI"](#), on page 74.

**Manual operation:**

See ["Serial Number"](#) on page 59

**:INSTruments:TYPE** <Type>

Selects the instrument's family.

**Parameters:**

<Type> List of CHAR-Data  
<TypeInstr#1>,<TypeInstr#2>,...

**Example:**

See [Chapter 6.5.1, "Configuring Instruments in the R&S SGMA-GUI"](#), on page 74.

**Manual operation:**

See ["Available Instruments"](#) on page 55

### 6.5.3 List of R&S SGMA-GUI Commands

:INSTruments:ACTive[:STATe].....	76
:INSTruments:COUnT?.....	76
:INSTruments:EACCEss[:STATe].....	76
:INSTruments:GPIB:ADDRess.....	78
:INSTruments:GPIB:BOARd.....	78
:INSTruments:MAPPing:FILE.....	77
:INSTruments:NAME.....	77
:INSTruments:REMOte:CHANnel.....	77
:INSTruments:REMOte:NAME.....	77
:INSTruments:SCAN.....	78
:INSTruments:SCAN:HNPPrefix.....	78
:INSTruments:SERial.....	78
:INSTruments:TYPE.....	79

## 7 Signal Generator Settings

This section summarizes the settings necessary to configure the instrument for signal generation. The description in this section follows the menu tree structure of the graphical user interface. Each of the discussed topics follows a common structure, providing basic background information, and reference to the user interface.

For step-by-step instructions for fulfilling typical tasks, refer to [Chapter 9, "Performing Configuration Tasks"](#), on page 147.

### 7.1 Operation Mode

You can operate the R&S SGS in two modes, normal mode and baseband bypass mode. In baseband bypass mode, an external IF signal fed in at the [I] or [Q] connectors is directly routed to the [RF OUT] connector. The level of the signal can be adjusted.

Refer to [Figure 5-9](#) for visualization of the signal flow.

- ▶ To access the "Operation Mode" dialog, select "SGMA-GUI > Instrument Name > Operation Mode".

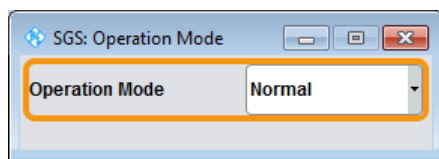

#### Operation Mode

Sets the operation mode.

"Normal"            The complete signal processing chain is used.

"Baseband Bypass"

The IF signal fed in at the [I] or [Q] connectors is directly routed to the [RF OUT] connector.

**Note:** The "Baseband Bypass" is a special operation mode. See also [Chapter 9.3, "How to Enable a Baseband Bypass Mode"](#), on page 151.

Remote command:

[ :SOURce ] :OPMode on page 235

### 7.2 Frequency/Phase Settings

Depending on the installed options, the instrument provides an adjustable output frequency in the frequency range of 1 MHz to 6 GHz or to 12.75 GHz.

Access:

- ▶ Select "SGMA-GUI > Instrument Name > Frequency/Phase".

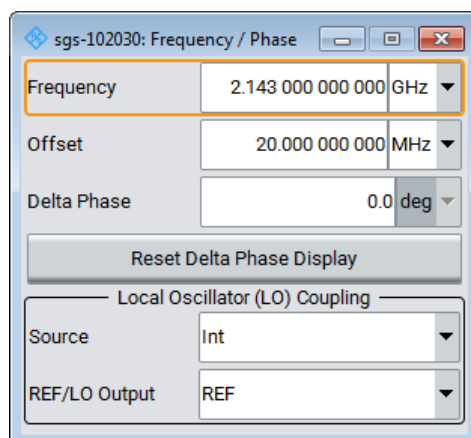

The frequency and phase related settings are provided in this dialog.

### Configuring the RF frequency

1. To change the RF frequency of the selected instrument, perform one of the following:
  - a) Select "SGMA-GUI > Instrument Name > Frequency/Phase > Frequency" and set the frequency at the RF output.
  - b) Select "SGMA-GUI main panel > Freq" and set the frequency. The value includes possible frequency offset.
2. To enable frequency offset for example to consider the frequency shift of a downstream instrument, set the parameter "Frequency/Phase > Offset".

Changes of the RF frequency have an immediate effect on the output signal.

### Frequency

Sets the RF frequency *at the RF output connector* of the selected instrument.

The displayed value does not consider an enabled frequency offset ([Offset](#)).

Remote command:

See [\[:SOURce\]:FREQuency\[:CW|FIXed\]](#) on page 236

### Offset

Sets a frequency offset.

The frequency offset value represents the frequency shift of a downstream instrument, as for example an attenuator or an amplifier.

Enabled frequency offset does not change the frequency at the RF output ([Frequency](#)). It influences the value of the parameter "SGMA-GUI main panel > Freq".

The following applies:

"Freq" = [Frequency](#) + "Offset"

In the "SGMA-GUI main panel", enabled frequency offset is also indicated with the keyword "Freq (Offs)".

Remote command:

[\[:SOURce\]:FREQuency:OFFSet](#) on page 236

#### Delta Phase

Sets the phase of the RF signal. The current phase of the signal is used as the reference. This function allows, for example, the phase of the output signal to be synchronized with the phase of a signal from a second signal generator.

Remote command:

[\[:SOURce\]:PHASe](#) on page 248

#### Reset Delta Phase Display

Resets delta phase value. The set phase is adopted as the new current phase, i.e. the delta phase value is reset to 0.

Remote command:

[\[:SOURce\]:PHASe:REFerence](#) on page 248

## 7.3 Local Oscillator (LO) Coupling

The LO coupling function allows you to distribute the local oscillator signal in a way that multiple R&S SGSs or other R&S signal generators can be driven by the same LO signal. This is mandatory for phase coherent application, e.g. the generation of beam-formed signals, and for phase coherent demodulation.



The LO coupling function is available only for instruments equipped with the option R&S SGS-K90 (Phase Coherence). This option enables phase coherent RF outputs of two or more RF signals. The local oscillator signal is provided at the REF/LO OUT connector. An external signal can be input at the REF/LO IN connector.

Refer to [Figure 5-9](#) for visualization of the signal flow.

See also:

- [Chapter 9.5, "How to Configure the Local Oscillator \(LO\) Coupling Source"](#), on page 153
- [Chapter 9.6, "How to Define the Signal at the REF/LO OUT Connector"](#), on page 154
- [Chapter 9.7, "How to Connect and Configure Instruments for Optimum Phase Coherence"](#), on page 154

### 7.3.1 Phase Coherence

Phase coherence of RF signals designates a defined, constant delta phase between two or more RF carrier signals with the same frequency or a multiple of the frequency.

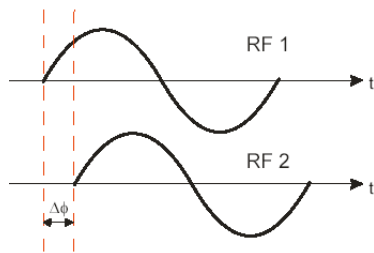

If two signal generators are coupled via their 10 MHz reference, they are generating exactly the same frequency but only in the long-term perspective. Having a closer look into the instantaneous differential phase ("delta phase") of these two RF signals, this is unstable due to:

- Phase noise of the two synthesizers
- "weak" coupling at 10 MHz and a long synthesis chain up to the RF domain
- Temperature differences, which cause slightly different phase drift for the different synthesizers

Most critical for a stable delta phase is the thermal RF phase fluctuation between multiple RF synthesizers. These fluctuations can be minimized by using a common synthesizer (common local oscillator (LO) signal) for all RF carriers.

See also [Chapter 9.7, "How to Connect and Configure Instruments for Optimum Phase Coherence"](#), on page 154.

### 7.3.2 Local Oscillator (LO) Coupling Settings

The LO coupling-related settings are provided in the "Frequency/Phase" dialog.

- To access this dialog, select "SGMA-GUI > Instrument Name > Frequency/Phase > Local Oscillator (LO) Coupling".

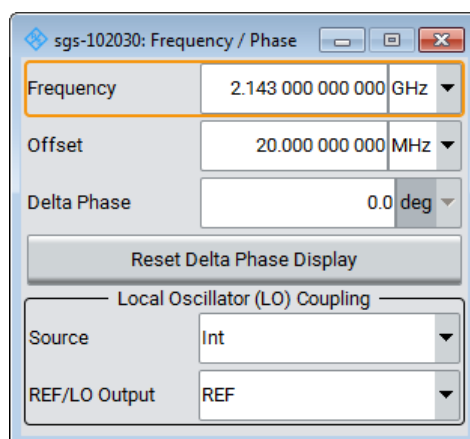

#### Source

Selects the source of the local oscillator signal.

"Int"                    The instrument uses the built-in local oscillator.

"Ext" The signal fed-in at the [REF/LO IN] input connector is used as signal source.



An icon in the block diagram indicates that an external LO source is used.

**Note:** The local oscillator input/output requires the additional software option R&S SGS-K90.

Remote command:

`[ :SOURce ] :LOSCillator :SOURce` on page 236

### REF/LO Output

Determines the signal provided at the output connector [REF/LO OUT].

See also [Chapter 9.6, "How to Define the Signal at the REF/LO OUT Connector"](#), on page 154.

"OFF" No signal is provided.

"LO" The signal of the local oscillator (LO) is available at the [REF/LO OUT] connector.

"REF" The signal of the reference oscillator is available at the [REF/LO OUT] connector.

Remote command:

`:CONNector :REFLo :OUTPut` on page 208

## 7.4 Reference Oscillator

The R&S SGS is equipped with an internal TXCO reference oscillator. If equipped with the additional HW option R&S SGS-B1, an OXCO can be used as an internal reference frequency source for the synthesizer. Moreover, an external reference signal source can be connected to the REF/LO IN connector of the instrument.

Refer to [Figure 5-9](#) for visualization of the signal flow.

- ▶ To access this dialog, select "SGMA-GUI > Instrument Name > Reference Oscillator".

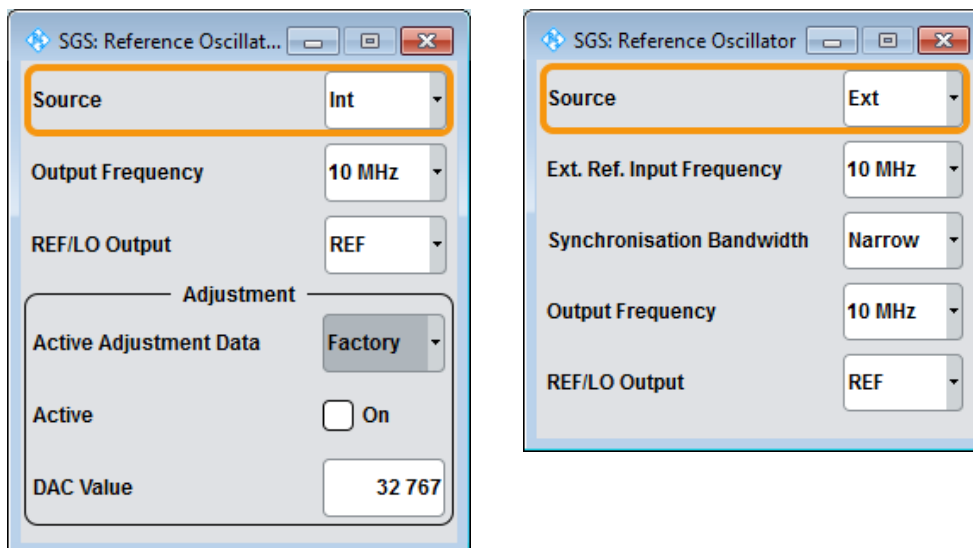

### Ref. Oscillator Source/Ext Ref On/Off

Determines whether the internal built-in oscillator (TXCO or OXCO) is used as a reference source or if an external reference is used. The internal reference oscillator OCXO requires the additional option R&S SGS-B1.

To feed in an external instrument reference, use the input connector [REF/LO IN]. To output the reference frequency at the output [REF/LO OUT], select "SGMA-GUI > Instrument Name > Ref. Oscillator > REF/LO Output > REF".

See also [Chapter 9.4, "How to Configure the Reference Oscillator Source"](#), on page 152.

"Int" The internal reference signal of 10 MHz is used.

"Ext" An external reference signal is used. The frequency of the external reference signal must be selected with the parameter "SGMA-GUI > Instrument Name > Ref. Oscillator > Ex. Ref. Input Frequency".

Remote command:

`[ :SOURce ] :ROSCillator :SOURce` on page 260

### Ext. Ref. Input Frequency

Available only for "Source > Ext".

Selects the frequency of the external reference signal.

Remote command:

`[ :SOURce ] :ROSCillator :EXTernal :FREQuency` on page 259

### Synchronization Bandwidth

Available only for "Source > Ext".

Selects the synchronization bandwidth for an external reference signal. The wideband setting is provided for using good reference sources of high spectral purity.

"Wide" Synchronization bandwidth is app. 250 Hz.

"Narrow" Synchronization bandwidth is app. 40 Hz.

Remote command:

[\[:SOURce\]:ROSCillator:EXTernal:SBANdwidth](#) on page 261

### Output Frequency

Selects the output for the reference oscillator signal. The available values depend on the input frequency and the reference oscillator source.

**Table 7-1: Output frequency**

"Reference Oscillator Source"	Input frequency	Output frequency
"Internal"	10 MHz	10 MHz 1 GHz
"External"	10 MHz 13 MHz 100 MHz 1 GHz	10 MHz, 1 GHz 13 MHz, 1 GHz 100 MHz, 1 GHz 1 GHz

Support of 13 MHz reference frequency requires that the instrument is equipped with hardware module RF board with part number 1419.5308.02.

To find out the RF board installed in the instrument:

- Select "SGMA-GUI > instrument name > Setup > Hardware Config" > "RF Assembly"
- Observe the part number of the assembly "RfBoard".

Remote command:

[\[:SOURce\]:ROSCillator:OUTPut:FREQuency](#) on page 260

### REF/LO Output

Determines the signal provided at the output connector [REF/LO OUT].

See also [Chapter 9.6, "How to Define the Signal at the REF/LO OUT Connector"](#), on page 154.

"OFF"	No signal is provided.
"LO"	The signal of the local oscillator (LO) is available at the [REF/LO OUT] connector.
"REF"	The signal of the reference oscillator is available at the [REF/LO OUT] connector.

Remote command:

[:CONNector:REFLo:OUTPut](#) on page 208

### Active Adjustment Data

Displays whether the factory or user defined (custom) calibration value is currently used for the external calibration of the reference oscillator.

Adjusting the calibration value for the OCXO adjustments is a protected service procedure, that requires a Protection Level 2 password. The exact test procedure is described in the service manual.

See also [Chapter 8.15, "External Adjustments"](#), on page 146.

**Adjustment Active**

Available only for "Source > Int".

Selects adjustment mode.

"OFF"	Uses the calibrated internal reference frequency. This value is determined at one of the R&S service centers during calibration.
"ON"	A user-defined adjustment value is used. The value is entered under <a href="#">DAC Value</a> . This allows the frequency to be impaired freely, for example, to simulate a frequency error. The instrument is no longer in the calibrated state. However, the calibration value is not changed and the instrument resumes the calibrated state after switching the "Adjustment State" to Off.

Remote command:

[\[:SOURce\]:ROSCillator\[:INTernal\]:ADJust\[:STATe\]](#) on page 260

**DAC Value**

Enters a user-defined adjustment value for the internal reference frequency. This value is not used unless "Adjustment Active > On" is selected.

"DAC Value = 0" indicates the calibrated state. The setting range depends on the reference oscillator type and its factory calibration value.

Remote command:

[\[:SOURce\]:ROSCillator\[:INTernal\]:ADJust:VALue](#) on page 260

## 7.5 Level and Power-On Settings

This section explains the level settings of the R&S SGS. The instrument can be equipped optionally with an active electronic step attenuator (R&S SGS-B26).

**Configuring RF level**

- ▶ To change the RF level of the selected instrument, perform one of the following:
  - a) Select "SGMA-GUI main panel > Level" and enter the desired value.
  - b) Select "SGMA-GUI > Instrument Name > Level > RF Level > Level" and enter the desired value.

Changes of the RF level have an immediate effect on the output signal.

### 7.5.1 RF Level

- ▶ To access the RF level settings, select "SGMA-GUI > Instrument Name > Level > RF Level".

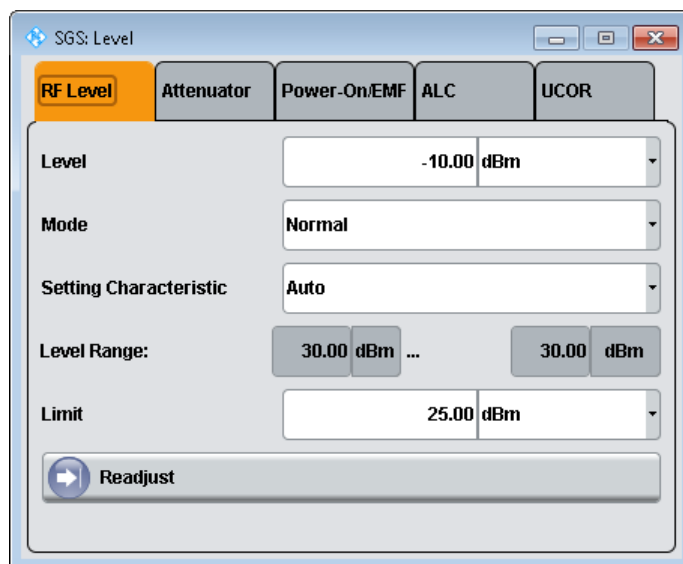

This dialog comprises settings like the RF level and level limit.

#### Level/Level Offset

Sets the RF level at the RF output connector of the selected instrument.

If you set a level offset, it will be indicated in the R&S SGMA-GUI main panel by a change in the name of this parameter from "Level" to "Level Offset".



**Note:** The SCPI command `[ :SOURce ] :POWER [ :LEVel ] [ :IMMediate ] [ :AMPLitude ]` sets the level of the "Level" display, that means the level containing offset while `[ :SOURce ] :POWER :POWER` sets the level at the RF output connector.

Remote command:

`[ :SOURce ] :POWER [ :LEVel ] [ :IMMediate ] [ :AMPLitude ]` on page 251

`[ :SOURce ] :POWER :POWER` on page 250

#### Offset

Sets a level offset.

This value represents the level shift of a downstream instrument, as for example an attenuator or an amplifier, and is indicated in the status bar of the display. It does not change the level at the RF output.

Remote command:

`[ :SOURce ] :POWER [ :LEVel ] [ :IMMediate ] :OFFSet` on page 252

**Mode**

Allows you to optimize the RF output signal for applications, where improved harmonic distortion or improved wideband noise is required.

- "Normal" In normal mode, the generator provides an RF output signal with high signal to noise ratio and low distortion, according to the data sheet.
- "Low Noise" This setting forces the generator to optimize the signal to noise ratio.
- "Low Distortion" In this mode, the generator reduces distortions of the RF signal to a minimum.

Remote command:

[\[:SOURce\]:POWER:LMODe](#) on page 250

**Setting Characteristic**

Selects the characteristic for the level setting. For some general applications, the instrument operation can be optimized by selecting one of the predefined level setting characteristics.

- "Auto" The instrument provides the highest dynamic range and the fastest setting times according to the data sheet. The RF signal is shortly blanked during the moment the step attenuator is switched on.
- "Uninterrupted Level setting" Suppresses level blanking at frequency and level changes. This mode reduces the dynamic range of the instrument. The step attenuator is fixed.
- "Strictly Monotone" Provides level setting without discontinuities. All electronic switches in the RF path are clamped. The operation mode is useful for applications using level searching algorithms. This mode further reduces the dynamic range of the instrument. The step attenuator is also fixed.
- "Constant-VSWR" Suppresses output impedance variations at the [RF Out] connector due to changed level setting. This mode reduces the dynamic range of the instrument. The step attenuator is fixed.

Remote command:

[\[:SOURce\]:POWER:SCharacteristic](#) on page 251

**Level Range**

Displays the level range within which the level setting is expected to work properly. The range limits depend on several parameters like "Mode", "Setting Characteristic", the I/Q signal's crest factor etc.

Remote command:

[\[:SOURce\]:POWER:RANGE:LOWer?](#) on page 253

[\[:SOURce\]:POWER:RANGE:UPPer?](#) on page 253

**Limit**

Sets the level limit.

The value specifies the upper limit of the level at the [RF Out] connector. A message appears if an attempt is made to set a level above this limit and the level at the RF output is confined to the upper limit. However, the level indication is not influenced.

The value is not affected by an instrument preset function. This parameter is influenced only by the **Factory Preset** and its factory value is equal to the upper limit.

Remote command:

`[ :SOURce ] :POWER:LIMit [ :AMPLitude ]` on page 252

**Readjust**

Recalculates the instrument internal settings optimized for the current level. Not required for automatic modes.

Remote command:

`[ :SOURce ] :POWER:ALC:SONCe` on page 249

## 7.5.2 Attenuator

- ▶ To access the attenuator settings, select "SGMA-GUI > Instrument Name > Level > Attenuator".

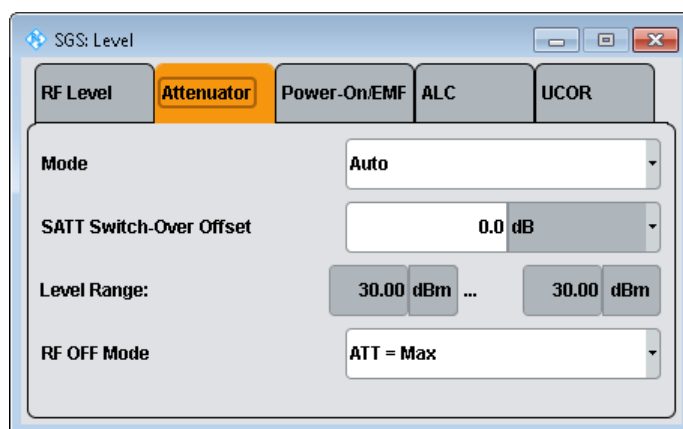

This dialog comprises the settings for the power-on behavior of the instrument.

**Mode**

Sets the attenuator mode at the RF output.

- |        |   |
|--------|---|
| "Auto" | Standard mode.<br>The electronically switching attenuator switches with a ~ 6 dB step width at optimized switching points. The entire level range is available.<br>The level setting is performed by continuous electronic level control combined with switching the step attenuator. |
|--------|---|

"Fixed" The level settings are made without switching the attenuator. When this operating mode is switched on, the attenuator is fixed in the current position to provide level settings without interruption. The resulting variation range is defined and displayed with the parameters [Level Range](#).

**Note:** The function is effective when automatic level control is activated ("ALC State = On").

If the normal variation range is overranged or underranged, level errors increase considerably. The warning "Level under/overrange" appears in the info line.

The spectral purity of the output signal decreases with high attenuation.

"Auto Passive" The attenuator is switched automatically. The level settings are made only for the passive reference circuits. The high-level ranges are not available.

Remote command:

[:OUTPut:AMODE](#) on page 222

#### SATT Switch-Over Offset

Sets the switch-over offset value of the attenuator.

Remote command:

[\[:SOURce\]:POWER:ATTenuation:SOVer\[:OFFSet\]](#) on page 250

#### Level Range

Displays the level range in which the level is set without interruption for the "Attenuator Mode Fixed" setting.

Remote command:

[:OUTPut:AFIXed:RANGe:LOWer?](#) on page 222

[:OUTPut:AFIXed:RANGe:UPPer?](#) on page 222

#### RF-Off-Mode

Determines the attenuator's state after the instrument is switched off.

In default setting, the electronic step attenuator switches to highest attenuation when RF is off. By setting the RF-Off mode, the electronic step attenuator can be fixed to keep the output impedance constant during RF off.

Remote command:

[\[:SOURce\]:POWER:ATTenuation:RFOff:MODE](#) on page 250

### 7.5.3 Power-On/EMF

- ▶ To access the power-on/EMF settings, select "SGMA-GUI > Instrument Name > Level > Power-On/EMF".

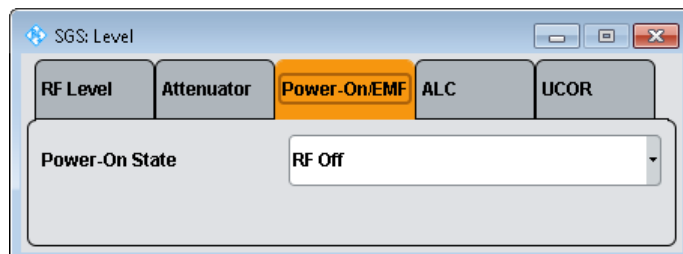

This dialog comprises the settings for the power-on behavior of the instrument.

#### Power-On State

Selects the state which the RF output takes after the instrument is switched on.

"RF Off" The output is deactivated when the instrument is switched on.

"Previous Setting"

When the instrument is switched on, the output takes the same state as it had when the instrument was switched off.

Remote command:

`:OUTPut [:STATe] :PON` on page 223

### 7.5.4 ALC

- ▶ To access the automatic level control (ALC) settings, select "SGMA-GUI > Instrument Name > Level > ALC".

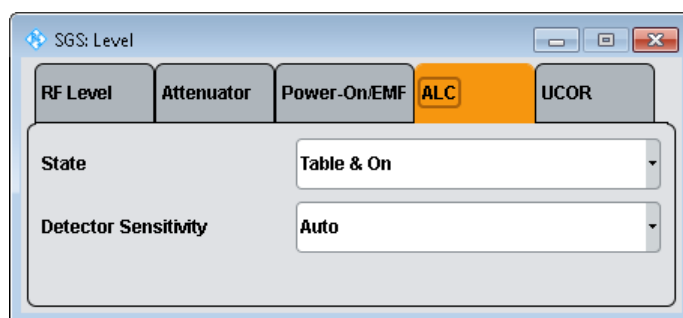

Automatic level control can be used with almost all applications, especially I/Q modulation. It only has to be deactivated for certain settings in the baseband and when I/Q impairments ("Impairments State On") are activated. This is indicated under the respective function.

By default, the instrument operates in "Table & On" mode to provide the highest level accuracy and fastest setting time. Level control can be switched to "Off (Table)" or "On" for particular applications. The "Off (Table)" state (level control Off) is recommended if in CW mode the signal/intermodulation ratio is to be improved for multi-transmitter measurements.

### State

Sets the internal level control.

"Table & On"	Default mode. First sets the level to the target value using the internal level table. Then activates the level control circuit to achieve maximum level accuracy.
"On"	Internal level control is permanently activated. If "On" and "Attenuator Mode Fixed" is selected, the level is recalibrated for every level and frequency setting.
"Off (Table)"	Internal level control is performed according to the ALC table.

Remote command:

[\[:SOURce\]:POWer:ALC\[:STATe\]](#) on page 249

### Detector Sensitivity

Allows you to fix the internal level detector. It is recommended to use the Auto mode (default).

"Auto"	Automatic detector selection. Recommended mode of operation.
"Low"	Low sensitivity detector selected. This setting is intended for signals with high internal electronic levels.
"Med"	Medium sensitivity detector selected. This setting corresponds to normal mode. It is intended for signals with medium internal electronic levels.
"High"	High sensitivity detector selected. Selects the detector path with high sensitivity, intended for signals with low internal electronic levels.
"Fix"	Fixes the last set sensitivity setting.

Remote command:

[\[:SOURce\]:POWer:ALC:DSENSitivity](#) on page 249

## 7.5.5 User Correction Settings

- ▶ To access the user correction level settings, select "SGMA-GUI > Instrument Name > Level > UCOR".

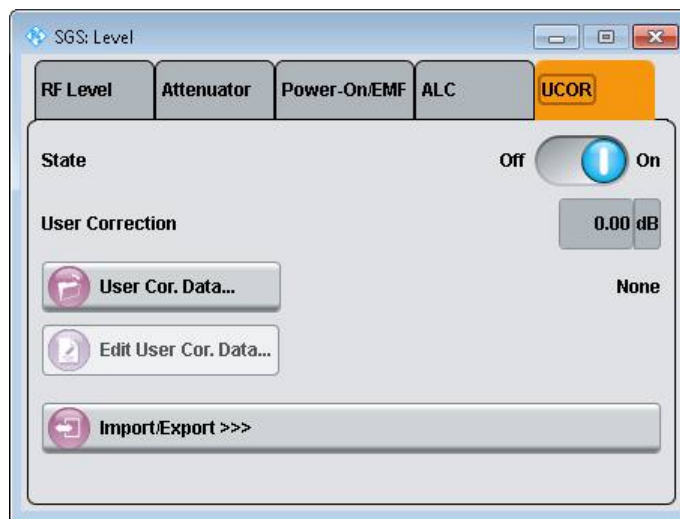

The "User Correction" function is used to create and activate lists in which level correction values predefined by the user are freely assigned to RF frequencies. Correction is performed by the user-defined table values being added to the output level for the respective RF frequency.

With frequencies which are not contained in the list, the level correction is determined by interpolation of the closest correction values.

The lists are created in the "List Editor". Each list is stored in its own file with the predefined file extension \*.uco. The name of the "User Correction" file can be freely selected. The files are loaded from the "Lists..." file manager. Externally created tables with pairs of frequency and level values can be converted into "User Correction" files using the import function. The external files must have the file extension \*.txt or \*.csv. These file formats are provided e.g. by the Microsoft Excel program. The separators for table columns and for decimal floating-point numerals can be set. In addition, internally created "User Correction" data can be exported into ASCII files using the export function.

If user correction is activated, the "UCOR" display ("User Correction") is shown in the header together with the "Level" display. The RF output level is the sum of both values.

"Level" + "UCOR" = Output level

If activated, user correction is effective in all operating modes.

### State

Activates/deactivates user correction.

Remote command:

[\[:SOURCE<hw>\]:CORREction\[:STATE\]](#) on page 245

### User Correction

Indicates the current value for level correction.

Remote command:

[\[:SOURCE<hw>\]:CORREction:VALue?](#) on page 245

**User Cor. Data**

Calls the "File Select" menu for selecting and creating a list or the "File Manager".

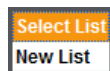

Remote command:

`[ :SOURce ] :CORRection:CSET:DELeTe` on page 240

`[ :SOURce<hw> ] :CORRection:CSET [ :SELeCt ]` on page 244

**Edit User Cor. Data**

Calls the editor for editing the selected user correction list.

A list consists of any number of frequency/level value pairs. The currently selected list is displayed.

Each list is saved as a separate file with extension \*.uco. The file name and the directory to which the file is saved are user-selectable.

**Note:** Save list only after filling both columns (frequency and level), otherwise the entries are lost.

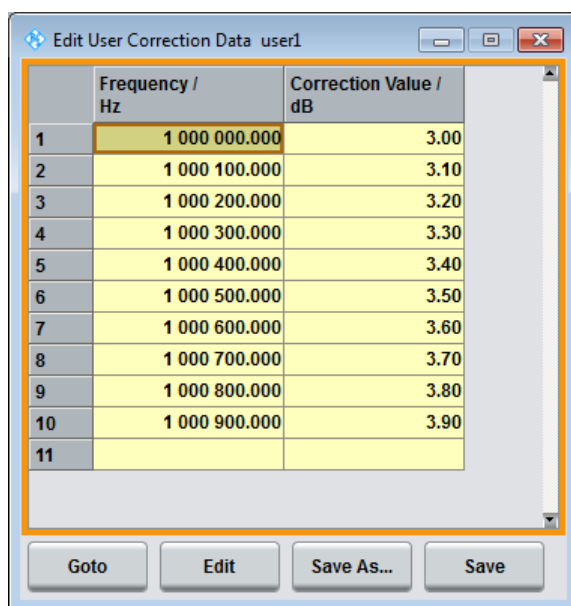

"Frequency /Hz"

Enters the frequency to which the level correction value applies.

**Note:** The "Fill..." function allows you to automatically enter any number of frequencies with freely selectable range and increment.

"Power/dB"

Enters the level correction value to which the specified frequency applies.

"Goto" Selects row for editing.



If "Goto Row" is selected, a window opens for entering the requested row.

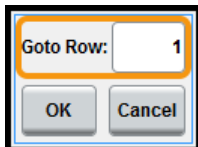

"Edit" Calls a selection of possible actions described below.

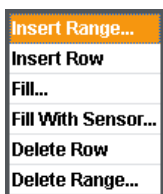

"Insert Range" Insert new rows before the marked row. The number of rows to be inserted can be defined in an entry window.

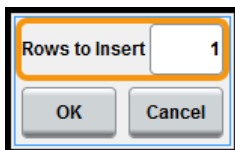

"Insert Row" Insert a new row before the marked row.

"Fill..." Opens a sub menu for defining a set of list values to be automatically entered in the ucor list, see [Filling the Correction List Automatically](#)).

"Fill with sensor..." Opens a dialog to configure the settings for automatic filling of user correction data with an R&S NRP power sensor, see [Chapter 7.5.7, "Fill with Sensor"](#), on page 99.

"Delete Row" Deletes the marked row.

"Delete Range..." Allows you to delete any number of rows starting with the marked row. The number of rows to be deleted can be defined in an entry window.

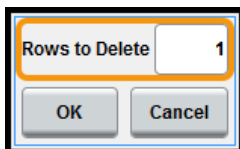

"Save as" Open the file menu to save the list under a new name.

**Note:** Save list only after filling both columns (frequency and level), otherwise the entries are lost.

Each list is saved to the R&S SGS hard disk as a separate file with the file prefix \*.ucco. The file name and the directory to which the file is saved are user-selectable.

"Save" The list is saved under its current name.

Remote command:

[\[:SOURce<hw>\]:CORRection:CSET\[:SElect\]](#) on page 244

[\[:SOURce<hw>\]:CORRection:CSET:DATA:FREQuency](#) on page 238

[\[:SOURce<hw>\]:CORRection:CSET:DATA:POWer](#) on page 239

### Import/Export >>>

Expands the menu with the area for import and export of user correction files.

Externally edited Excel tables with any number of frequency/level value pairs can be imported as text or \*.csv files and used for user correction.

Conversely, you can also export internally created user correction lists as text or \*.csv files.

### Mode

Selects if user correction lists should be imported or exported. The settings offered depend on the selected mode.

Remote command:

[\[:SOURce<hw>\]:CORRection:DEXChange:MODE](#) on page 243

### Extension

Selects the file extension of the ASCII file to be imported or exported. Selection "TXT" (text file) or "CSV" (Excel file) is available.

Remote command:

[\[:SOURce<hw>\]:CORRection:DEXChange:AFIle:EXTension](#) on page 241

### Decimal Point

Selects the decimal separator used in the ASCII data between '.' (decimal point) and ',' (comma) with floating-point numerals.

Remote command:

[\[:SOURce<hw>\]:CORRection:DEXChange:AFIle:SEParator:DECimal](#)

on page 242

### Column Separator

Selects the separator between the frequency and level column of the ASCII table the user correction list is exported to or imported from.

Remote command:

[\[:SOURce<hw>\]:CORRection:DEXChange:AFIle:SEParator:COLumn](#)

on page 242

**Select ASCII Source/Destination**

Calls the "File Manager" for selecting the ASCII file to be imported into a user correction list (source) or the ASCII file the user correction list is exported (destination) in.

Remote command:

`[ :SOURce<hw> ] :CORRection:DEXChange:AFILe:SElect` on page 241

**Select Destination/Source**

Calls the "File Manager" for selecting the user correction list to be exported (source) into an ASCII file or the destination for the ASCII file to be imported (destination) in.

Remote command:

`[ :SOURce<hw> ] :CORRection:DEXChange:SElect` on page 244

**Import/Export**

Starts the export or import of the selected file.

When import is selected, the ASCII file is imported as user correction list.

When export is selected, the user correction list is exported into the selected ASCII file.

Remote command:

`[ :SOURce<hw> ] :CORRection:DEXChange:EXECute` on page 243

**7.5.6 Filling the Correction List Automatically**

The "Fill Table" menu enables you to set the level correction values automatically.

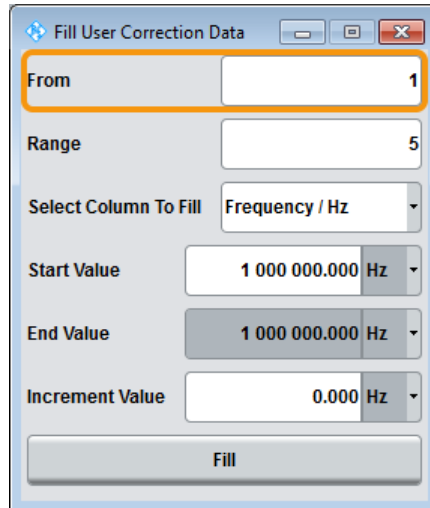

The start line and the number of rows to be filled are defined under "From" and "Range."

The column to be filled is selected under "Select column to fill". Depending on the selection here, the default for start, end, and increment value are set. As the settings are interdependent, a change of one parameter may result in the automatic change of one or more of the other parameters. The filling of the column with the selected value settings is started with button "Fill".



The correction list entries are only computed when the "Fill" button is pressed.

**From**

Sets the start value of the index range.

Remote command:

n.a.

**Range**

Sets the range for filling the table.

Remote command:

n.a.

**Select column to fill**

Selects either the frequency or the level column to be filled with the value defined below.

Remote command:

n.a.

**Start value**

Sets the start value for the frequency or the level entries.

Remote command:

n.a.

**End value**

Displays the end value for the frequency or the level entries.

Remote command:

n.a.

**Increment value**

Sets the increment for the frequency or the level entries.

Remote command:

n.a.

**Fill**

Fills the selected column in the set range with values, starting with the start value and using the set increment.

Remote command:

n.a.

### 7.5.7 Fill with Sensor

- ▶ To access this dialog, select "SGMA-GUI > Instrument Name > Level > UCOR > Edit User Cor. Data> Fill With Sensor".

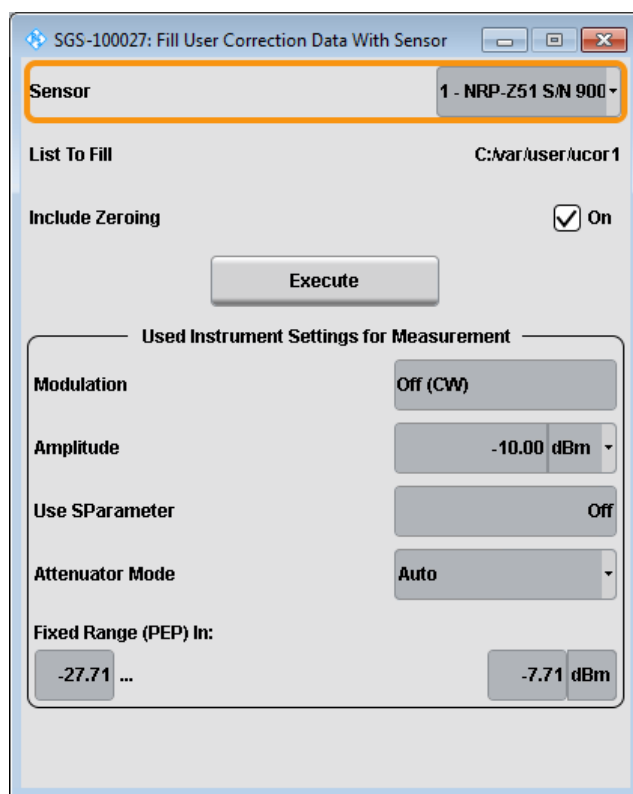

This dialog describes all parameters for filling a table automatically with sensor readings.



Since the settings are interdependent, the affected parameters change accordingly if you set a value.

To fill the table, press the "Execute" button.

To select the sensor and determine its parameters, refer to [Chapter 7.5.8.3, "NRP Power Viewer"](#), on page 105.

#### Fill User Correction Data with Sensor

- "Sensor"  
Displays connected sensors for selection.
- "List To Fill"  
Indicates the used list.
- "Include Zeroing"  
Performs a zeroing procedure before acquiring the user correction data to improve precision. Since during zeroing no signal may be applied to the sensor, RF is temporarily switched off at the generator.  
When unchecked, the zeroing procedure is skipped. However, the RF signal level might be blanked shortly. This setting is recommended if blanking of RF is undesirable or the absence of power at the sensor cannot be guaranteed.
- "Execute"

The "Execute" button is only enabled if a sensor is detected and the user correction list contains at least one frequency value.

Remote command:

`[ :SOURce<hw> ] :CORRection:ZERoing:STATe` on page 245

`[ :SOURce<hw> ] :CORRection:CSET:DATA [ :SENSor<ch> ] [ :POWER ] :SONCe`  
on page 240

#### Used Instrument Settings For Measurement

Displays the settings relevant for the measurement.

- "Modulation"      Indicates the modulation state
- "Amplitude"      Shows the currently set level.
- "Use SParameter"  
                         Indicates whether SParameter correction is used.
- "Attenuator Mode"  
                         Displays the selected mode of the attenuator.
- "Fixed range (PEP) In"  
                         Shows the level range.

Remote command:

n.a.

### 7.5.8 Using Power Sensors

The R&S SGS works with most of the R&S NRP power sensors and thus supports various application tasks. Using power sensors, you can for example determine attenuation characteristics of downstream equipment or cables. You can use the measured values to compensate the losses with internal control functions or with an external control circuit in real time.

R&S NRP sensors are highly accurate standalone measuring devices, suitable for a wide range of applications. The devices communicate directly with the signal generator, calculate the average or peak power internally, include S-parameter correction and return the measurement results to the generator.

The R&S SGS works with any sensor of the R&S NRP series and can perform up to four power measurements simultaneously.



Check the firmware version of the R&S NRP sensors regularly. Update the firmware, if necessary.

For updates, see the Rohde & Schwarz website <http://www.rohde-schwarz.com> in section "Power Meters & Voltmeters".

- [Connecting R&S NRP Power Sensors to the R&S SGS](#)..... 102
- [NRP Sensor Mapping](#)..... 103
- [NRP Power Viewer](#)..... 105

### 7.5.8.1 Connecting R&S NRP Power Sensors to the R&S SGS

R&S NRP sensors are connected to the R&S SGS in the following ways:

- Connection to the USB connector  
Requires a USB Adapter Micro-A to A and the following cables, depending on the used sensor type:
  - R&S NRP-ZK6 and an R&S NRP-Z3 with external power supply for R&S NRPxx power sensors
  - R&S NRP-Z3 with external power supply for sensors of the R&S NRP-Zxx family
- Connection via R&S NRP-Z5 sensor hub, see [Using the R&S NRP-Z5 sensor hub](#).
- Connection via USB hub with external power supply unit, see [Using USB hub](#).
- Connection via LAN for R&S NRPxxxSN power sensors  
Using the Ethernet interface requires PoE (Power over Ethernet) to provide the electrical power.  
To establish the connection, you can use:
  - A PoE Ethernet switch, e.g. R&S NRP-ZAP1 and an RJ-45 Ethernet cable.
  - A PoE injector and an RJ-45 Ethernet cable.

#### Using the R&S NRP-Z5 sensor hub

The R&S NRP-Z5 USB sensor hub (high-speed USB 2.0) can host up to 4 R&S NRP sensors. It provides simultaneous internal and external triggering of all connected sensors.

[Figure 7-1](#) illustrates the connection as principle. For details, see the description [R&S®NRP®Series Power Sensors getting started](#).

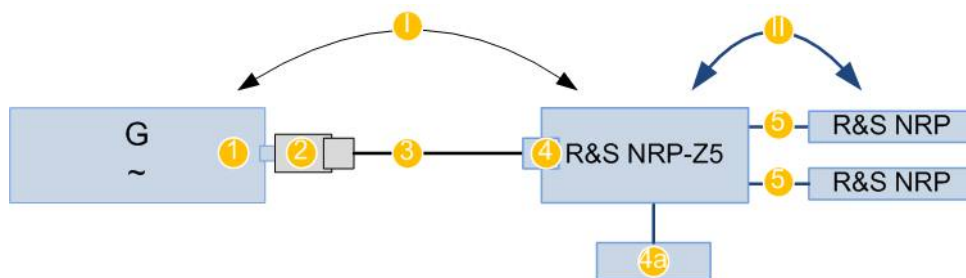

**Figure 7-1: Connecting power sensors to the R&S SGS via R&S NRP-Z5 sensor hub**

I, II = [Connection order](#)

G = Signal source (R&S SGS)

1 = USB type Micro-A connector

2 = USB Adapter Micro-A to A

3 = Standard USB cable with USB type A and USB type B connectors

4 = USB type B connector

4a = External power supply unit, incl. power cable (supplied with the R&S NRP-Z5)

5 = Cable R&S NRP-ZK6 per sensor of the R&S NRPxx power sensor family; no further adapter cables for sensors of the R&S NRP-Zxx family

### Using USB hub

Figure 7-2 illustrates the connection as principle. For details, see the description R&S®NRP®Series Power Sensors getting started.

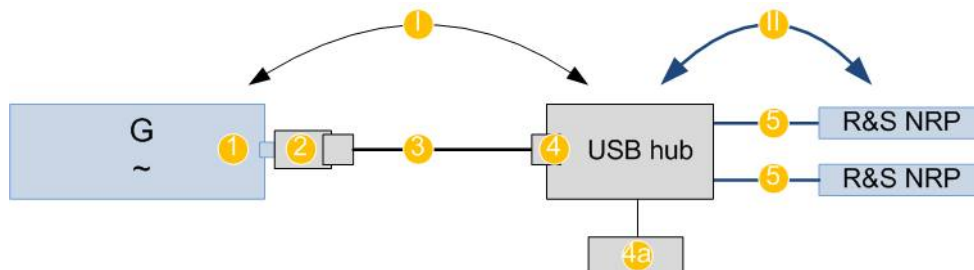

Figure 7-2: Connecting power sensors to the R&S SGS via USB hub

I, II = Connection order

G = Signal source (R&S SGS)

1 = USB type Micro-A connector

2 = USB Adapter Micro-A to A

3 = Standard USB cable with USB type A and USB type B connectors

4 = USB type B connector

4a = External power supply unit and extra power cable

5 = Cable R&S NRP-ZKU per sensor of the R&S NRPxx power sensor family; R&S NRP-Z3 or R&S NRP-Z4 USB adapter cables for sensors of the R&S NRP-Zxx family

### Connection order

Always connect the equipment in the following order:

1. Connect the R&S NRP-Z5 sensor hub or the USB hub to the power supply and to the R&S SGS
2. Switch on the R&S SGS
3. Connect/disconnect the R&S NRP sensors

### Detection and mapping

The R&S SGS automatically detects a connected R&S NRP power sensor and indicates it in the "NRP Power Viewer" and "NRP Sensor Mapping" dialogs.

You can change the default mapping in the [NRP Sensor Mapping](#) dialog.



On connection, the R&S SGS immediately starts the measurement of a detected R&S NRP power sensor. If you perform an instrument preset, the R&S SGS stops the measurements. The connection and the mapping of the power sensors remain, the measurements must be restarted.

#### 7.5.8.2 NRP Sensor Mapping

The "NRP Sensor Mapping" lists all R&S NRP sensors detected by the instrument.

Any R&S NRP sensor that supports the USB legacy protocol and is connected to one of the USB interfaces, is detected automatically and added to the list. Vice versa, the R&S SGS removes a sensor from the list, when it is disconnected.

R&S NRP sensors that are connected via LAN or use the USBTMC protocol are not automatically detected. They are detected by the scan search function.

Access:

- ▶ Select "Instrument" > "NRP Sensor Mapping".

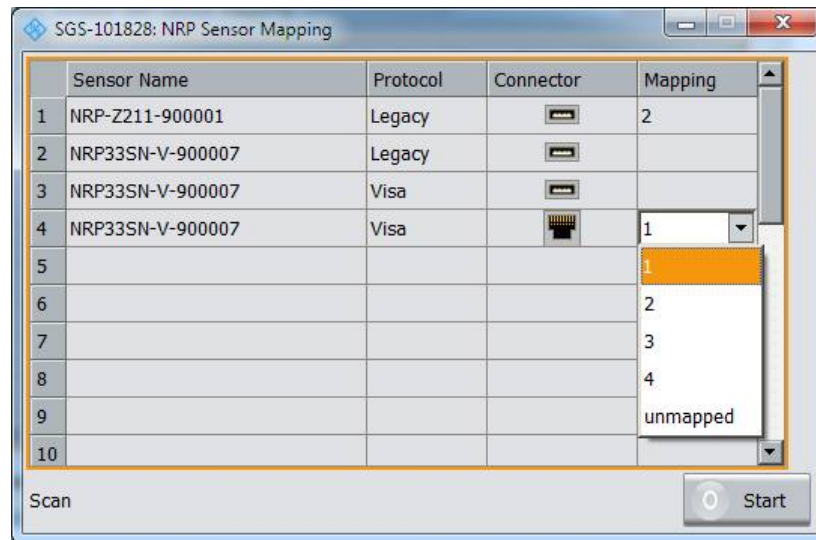

The dialog lists all detected R&S NRP sensors for selection and mapping. You can also browse the network for sensors.

The detected sensors are characterized by the used protocol and the corresponding connector icon. In the "Mapping" column, you can assign the sensor to one of the available sensor channels. The list can contain several entries but the R&S SGS can only use up to four sensors simultaneously.

**Settings**

Sensor Mapping List ..... 104  
 Scan ..... 105

**Sensor Mapping List**

Displays a list of all sensor entries with information on the sensor name, the used protocol, the connector and the assigned mapping.

If a sensor is connected via LAN or uses the USBTMC protocol, its protocol is indicated as "Visa".

Remote command:

- :SLIST[:LIST]? on page 226
- :SLIST:ELEMENT<ch>:MAPPING on page 226
- :SLIST:SENSOR:MAP on page 227

### Scan

Scans the network and the USB connections for sensors connected via the VISA communication protocol, i.e. sensors that are addressed via LAN or USBTMC.

Sensors communicating via the USB legacy protocol are detected automatically.

Remote command:

:SLISt:SCAN[:STATe] on page 226

### 7.5.8.3 NRP Power Viewer

The R&S SGS features the power viewer function for measuring or monitoring signals with R&S NRP power sensors.

The R&S SGS can perform up to four power measurements simultaneously. The measured signals can be the RF output power or other selected signal sources.

#### About

The R&S SGS can perform up to four power measurements simultaneously.

Depending on the signal characteristic (CW, AM, pulsed, etc.) or the parameter to be measured (average, peak, etc...) a suitable R&S power sensor must be used.

#### About the measuring principle, averaging filter, filter length, and achieving stable results

A sensor measures the average or peak RF power of the source continuously. The measurement results are displayed in the "NRP Power Viewer" dialog.

The power viewer function uses **averaging filters** for getting a stable readout.

Measurement results could be interfered for instance by too much noise in your setup, by a bad suppression of harmonics or non harmonics or when you reach the sensitivity level of your power sensor.

Measurements are continuously repeated in a predefined time window. The measurement result is obtained by averaging the measured values for the last  $2N$  time windows. This approach is referred to as a **two-step averaging process**.

The factor of 2 in the formula arises because the output signals from the microwave detector are chopped at the same rate as the time windows to suppress low-frequency noise. An independent measured value can only be obtained from two consecutive values.

The variable  $N$  in the formula indicates the **filter length**. The filter length then directly influences the measurement time. The filter length can be selected automatically or it can be manually set to a fixed value.

Depending on the R&S NRP power sensor type, the manual setting of the filter length varies in resolution:

- Resolution = 1 for the R&S NRPxx power sensor family
- Resolution =  $2^n$  for R&S NRP-Zxx power sensors, with  $n = 1$  to 16

Follow the following general recommendation to find out the **optimum filter length**:

- Always start a measurement in auto mode ("Filter > Auto").  
Check if the measurement results are sufficient.
- If the power is not constant, select the filter length manually ("Filter > User").  
Trigger the "Auto Once" function to search for the optimum filter length for the current measurement conditions.  
The estimated value is indicated as filter length.
- If the target measurement accuracy value is known, select "Filter > Fixed Noise".  
The averaging factor is selected automatically and so that the sensor's intrinsic noise (two standard deviations) does not exceed the specified noise content.
- Different sensor types achieve the same filtering result with different filter and time window lengths.  
The time window length depends on the sensor type:
  - For most sensors, it is fixed to 20 ms.
  - For the R&S NRP-Z81 sensor, it is 10  $\mu$ s.  
The R&S NRP-Z81 uses filter length that is 1000 times larger than the filter length for other sensors.

### About zeroing

Activates the auto zero function.

Zeroing calibrates the external power sensor by adjusting its reading at zero signal power. For this purpose, the RF power source must be switched off or disconnected from the sensor. If a Rohde & Schwarz power sensor receives an input power during the zeroing process, it aborts zeroing and generates an error message. Zeroing takes a few seconds, depending on the sensor model. Refer to the documentation of your power sensor for more information.

### Tips for zeroing

When to perform zeroing:

- During warm up after switching on or connecting the instrument
- After a substantial change of the ambient temperature
- After fastening the power sensor module to an RF connector at high temperature
- After several hours of operation
- When low-power signals are to be measured, e.g. less than 10 dB above the lower measurement limit.
- Switch off the RF power source for zeroing, but do not disconnect it from the power sensor. This proceeding keeps the thermal equilibrium, and the zeroing process also compensates the noise that superimposes the measured signal (e.g. from a broadband amplifier).

### Related settings and functions

- Measurements-related settings, like results, filter, filter length:  
[NRP Power Viewer Settings](#)
- Sensor-specific information and sensor software update:  
[Chapter 8.5, "NRP Info"](#), on page 134

- Software version of the connected power sensor:  
`:SENSe<ch>[:POWER]:TYPE?` on page 235
- Acquisition of level correction data:  
[Chapter 7.5.5, "User Correction Settings"](#), on page 93.

#### Additional information

See Rohde & Schwarz website <http://www.rohde-schwarz.com> in section "Power Meters & Voltmeters" for:

- R&S NRP power sensor manual.
- Information on the R&S NRP-Z5 sensor hub and the available accessories.
- Sensor software updates.

#### NRP Power Viewer Settings

Access:

- ▶ Select "Instrument" > "NRP Power Viewer".

The "Overview" tab shows the list of detected sensors, and provides a separate tab per sensor.

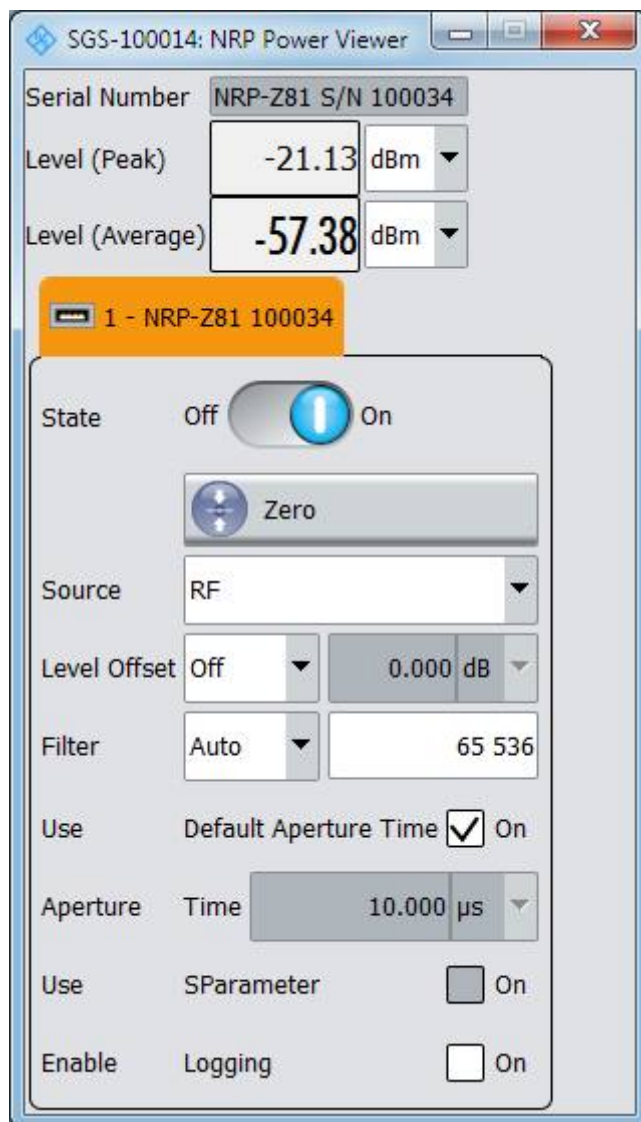

A sensor tab contains all parameters for configuring the sensor settings, like average or peak display, reference source, filter and level offset.

The remote commands required to define these settings are described in [Chapter 11.12, "SENSe, READ, INITiate and SLISt Subsystems"](#), on page 223, including the triggering of the measurement and the retrieval of measurement results.

**Settings:**

- [Sensor type and serial number](#) ..... 109
- [Level \(Peak\) / Level \(Average\)](#) ..... 109
- [Sensor Mapping](#)..... 109
- [Sensor Settings](#)..... 109
  - [L State](#) .....109
  - [L Zero](#) .....109

L Source.....	110
L Frequency .....	110
L Level Offset State,Level Offset.....	110
L Filter.....	110
L Filter Length.....	111
L Auto Once.....	111
L Noise Content.....	111
L Timeout.....	111
L Default Aperture Time.....	111
L Aperture Time.....	112
L S-Parameter .....	112
L Enable Logging.....	112

### Sensor type and serial number

Indicates the type and the serial number of the selected R&S NRP power sensor, and the channel the sensor is assigned to.

The displayed [Level \(Peak\) / Level \(Average\)](#) values correspond to the particular sensor.

Remote command:

`:SENSe<ch>[:POWer]:TYPE?` on page 235

`:SENSe<ch>[:POWer]:SNUMber?` on page 233

### Level (Peak) / Level (Average)

Indicates the measured peak or average level value.

You can also change the unit for the results display: Watt, dBm or dBμV.

**Note:** Peak level measurements are provided if the power sensor supports this feature.

Remote command:

`:READ<ch>[:POWer]?` on page 227

`:SENSe<ch>:UNIT[:POWer]` on page 228

### Sensor Mapping

Accesses the [NRP Sensor Mapping](#) dialog.

### Sensor Settings

One tab per sensor provides the corresponding setting parameters.

#### State ← Sensor Settings

Activates level measurement.

Remote command:

`:INITiate<hw>[:POWer]:CONTinuous` on page 227

To query the availability of a sensor at a given connector, use the command :

`SENSe<ch>[:POWer]:STATus[:DEVIce]?` on page 234.

#### Zero ← Sensor Settings

Activates the auto zeroing.

For details, see ["About zeroing"](#) on page 106.

Remote command:

`:SENSe<ch>[:POWer]:ZERO` on page 235

#### Source ← Sensor Settings

Selects the source for measurement.

"RF"	Assigns the signal to the RF path of the R&S SGS. The R&S SGS transfers the RF frequency and level settings to the R&S power sensor automatically. Thus you achieve power readings of high accuracy, irrespective from the connected sensor type.
"User"	Sets a user defined frequency.

#### Example:

If you have a frequency converting device between the generator and the DUT. If the frequency converter doubles the frequency, you can set twice the frequency in the R&S SGS. The R&S power sensor considers this RF frequency setting.

Set the parameter [Frequency](#) to the measurement's frequency.

Remote command:

`:SENSe<ch>[:POWer]:SOURce` on page 234

#### Frequency ← Sensor Settings

Defines the frequency value if "Source > User" is used.

Remote command:

`:SENSe<ch>[:POWer]:FREQuency` on page 232

#### Level Offset State, Level Offset ← Sensor Settings

Activates and defines a level offset which is considered in the power measurement result. The level offset value is always expressed in dB, irrespective of the display of the measurement result.

This function allows you to consider, for example, an attenuator in the signal path.

Remote command:

`:SENSe<ch>[:POWer]:OFFSet` on page 233

`:SENSe<ch>[:POWer]:OFFSet:STATe` on page 233

#### Filter ← Sensor Settings

Selects the way the length of the used filter is defined.

See also "[About the measuring principle, averaging filter, filter length, and achieving stable results](#)" on page 105.

"Auto"	Selects the filter length automatically and adjusts it to the measured value. The value is indicated with the parameter <a href="#">Filter Length</a> . When high output power is applied, the filter length and therefore the measurement time can be short. When low output power is applied, the filter length and therefore the measurement time is increased which reduces the considered noise content in your measurement.
--------	---

- "User" The filter length is defined manually, with the parameter [Filter Length](#). As the filter length works as a multiplier for the time window, constant filter length results in a constant measurement time. Values 1 and 2N are allowed.
- "Fixed Noise" The averaging factor is taken automatically in accordance to the value [Noise Content](#). Thus, the sensor's intrinsic noise (2 standard deviations) does not exceed the specified noise content. To avoid long measurement times when the power is too low, set a [Timeout](#). Timeout is the maximum acceptable measurement time which limits the averaging factor and therefore leads to a more unstable readout.

Remote command:

`:SENSe<ch>[:POWer]:FILTer:TYPE` on page 232

#### **Filter Length ← Sensor Settings**

Sets or indicates the filter length, depending on the selected filter mode.

- "Filter > Auto" indicates the automatically adjusted filter length.
- "Filter > User" enables you to set the filter length manually.
- "Filter > Fixed Noise" hides the setting parameter.

Remote command:

`:SENSe<ch>[:POWer]:FILTer:LENGth:AUTO?` on page 230

`:SENSe<ch>[:POWer]:FILTer:LENGth[:USER]` on page 230

#### **Auto Once ← Sensor Settings**

Searches the optimum filter length for the current measurement conditions. The result is indicated with the parameter [Filter Length](#).

See also "[About the measuring principle, averaging filter, filter length, and achieving stable results](#)" on page 105.

Remote command:

`:SENSe<ch>[:POWer]:FILTer:SONCe` on page 231

#### **Noise Content ← Sensor Settings**

For [Filter > Fixed Noise](#), sets the noise content.

Remote command:

`:SENSe<ch>[:POWer]:FILTer:NSRatio` on page 231

#### **Timeout ← Sensor Settings**

For "Filter > Fixed Noise", sets a time limit for the averaging process.

Remote command:

`:SENSe<ch>[:POWer]:FILTer:NSRatio:MTIME` on page 231

#### **Default Aperture Time ← Sensor Settings**

The sensor default setting is sufficient. Disable this parameter to specify a user-defined aperture time per sensor, if, for example, the readings vary.

To obtain stable readings, set the [Aperture Time](#) exactly to one modulation period.

Remote command:

`:SENSe<ch>[:POWer]:APERTure:DEFAult:STATe` on page 228

**Aperture Time ← Sensor Settings**

If "Use Default Aperture Time > Off", defines the acquisition time per sensor.

For example, to obtain a sufficient low average value, set the aperture time exactly to one modulation period.

Remote command:

```
:SENSe<ch>[:POWer]:APERture:TIME on page 229
```

**S-Parameter ← Sensor Settings**

S-Parameter correction is used to mathematically shift the reference plane to the DUT by considering the S-parameters for any components connected upstream of the sensor.

The S-Parameter table can be changed with the S-Parameters tool, provided as part of the free R&S NRP Toolkit software. For more information, refer to the manual of the connected R&S NRP power sensor.

Remote command:

```
:SENSe<ch>[:POWer]:CORRection:SPDevice:STATe on page 229
```

```
:SENSe<ch>[:POWer]:CORRection:SPDevice:LIST? on page 229
```

```
:SENSe<ch>[:POWer]:CORRection:SPDevice:SElect on page 229
```

**Enable Logging ← Sensor Settings**

Activates recording of R&S NRP power sensor readings in a log file.

There is 1 log file per sensor. The log files are created automatically and filled in continuously. They are text files with predefined filename `SensLog<n>.txt`, where `<n>` indicates the connected sensor. Log files are stored on the internal memory, in the directory `/var/sgs/SensorLogging`.

Each log file contains the measured value (2 readings when you work with peak sensors), the sensor type, and the measurement time (timestamp). Logged data is not overwritten. When a new measurement is started, the collected logging data is appended in the log file.

Check the used disc space regularly and remove log files to maintain storage capacity.

**Note:** The logging function is intended for measurements with long time intervals. It is suitable source for data reconstructions if the connection to the sensor was interrupted.

Remote command:

```
:SENSe<ch>[:POWer]:LOGGing:STATe on page 233
```

## 7.6 Pulse Modulation

This section explains the pulse modulation settings of the R&S SGS. The equipment layout for generating the pulse modulation signal includes the option Pulse Modulator (R&S SGS-K22).

To configure and perform a pulse modulation, you need to select the modulation signal source and provide the corresponding settings.

### Modulation signal sources

The R&S SGS provides the following signal sources for the signal modulation:

- **Internal:** A high-performance pulse generator, that allows you to generate either single or double pulse signals
- **Externally supplied signal:** the instrument expects the pulse modulation signals at the [TRIG] connector.

### Pulse modulation signal waveforms

The high-performance pulse generator enables you to generate single or double pulse signals.

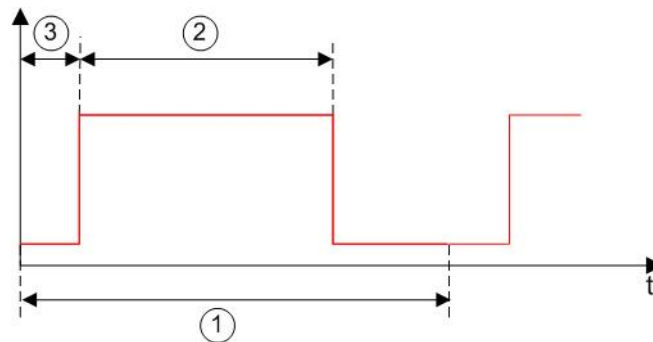

**Figure 7-3: Pulse generator - single pulse mode**

- 1 = Pulse period
- 2 = Pulse width
- 3 = Pulse delay

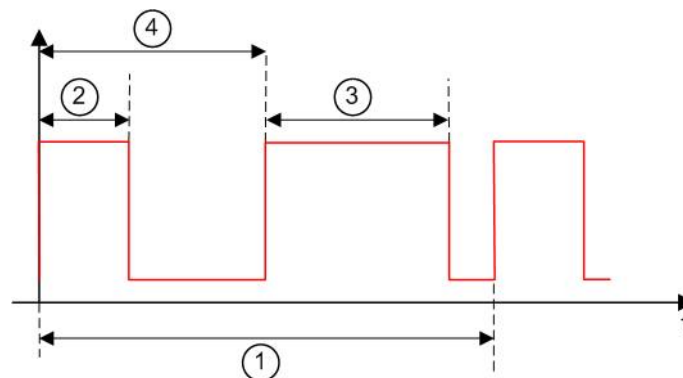
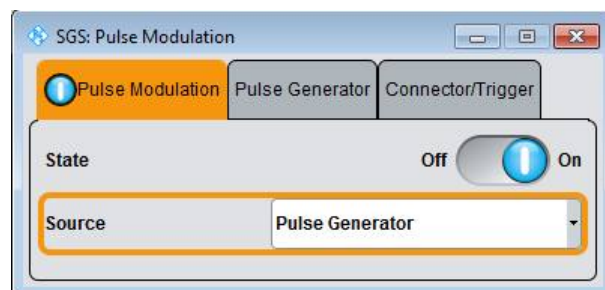

**Figure 7-4: Pulse generator - double pulse mode**

- 1 = Pulse period
- 2 = Pulse width
- 3 = Double pulse width
- 4 = Double pulse delay

### 7.6.1 Pulse Modulation Settings

- ▶ To access the pulse modulation settings, select "SGMA-GUI > Instrument Name > Pulse Modulation".



The "Pulse Modulation" dialog contains all parameters required to configure pulse modulation and pulse signal generation.

#### State

Activates pulse modulation.

The R&S SGMA-GUI indicates an activated pulse modulation as follows:



Remote command:

[\[:SOURce<hw>\]:PULM:STATe](#) on page 257

#### Source

Selects between the internal "Pulse Generator", or an "External" pulse signal for the modulation. In the later case, the instrument expects the pulse modulation signals at the [TRIG] connector.

Remote command:

[\[:SOURce<hw>\]:PULM:SOURce](#) on page 257

#### Polarity

Sets the polarity of the active slope of the modulation signal for "Source > External".

Remote command:

[\[:SOURce<hw>\]:PULM:POLarity](#) on page 257

#### External Impedance

Selects the input impedance for an external pulse modulation signal.

Remote command:

[\[:SOURce<hw>\]:PULM:TRIGger:EXTernal:IMPedance](#) on page 258

## 7.6.2 Pulse Generator Settings

- ▶ To access the pulse connector/trigger settings, select "SGMA-GUI > Instrument Name > Pulse Modulation > Pulse Generator".

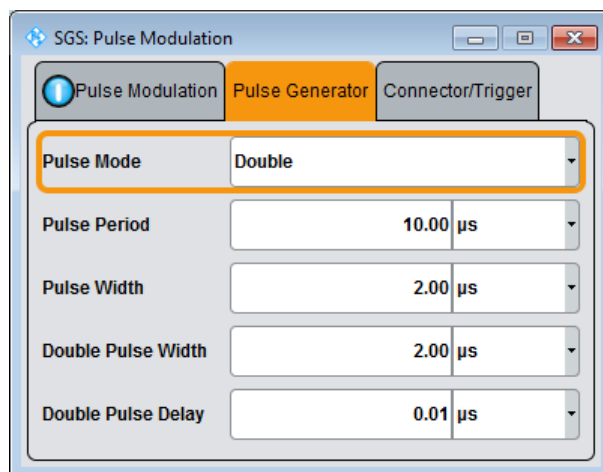

Comprises the settings necessary to configure the internal pulse modulation signal.

### Pulse Mode

Sets the operating mode of the pulse generator.

"Single" Generates a single pulse in one pulse period, see [Figure 7-3](#).

"Double" Generates two pulses in one pulse period, see [Figure 7-4](#).

Remote command:

[ :SOURce<hw> ] :PULM:MODE on page 256

### Pulse Period

Sets the repetition rate of the generated pulse signal, see "[Pulse modulation signal waveforms](#)" on page 113.

Remote command:

[ :SOURce<hw> ] :PULM:PERiod on page 256

### Pulse Width

Sets the pulse duration of the generated pulse signal, see "[Pulse modulation signal waveforms](#)" on page 113.

Remote command:

[ :SOURce<hw> ] :PULM:WIDTH on page 259

### Double Pulse Width

Sets the width of the second pulse, see [Figure 7-4](#).

Remote command:

[ :SOURce<hw> ] :PULM:DOUBLE:WIDTH on page 256

**Pulse Delay**

Sets the pulse delay. The pulse delay determines the time that elapses after a trigger event before pulse modulation starts, see [Figure 7-3](#).

The pulse delay is not effective for double pulse generation.

Remote command:

`[ :SOURce<hw> ] :PULM:DELay` on page 255

**Double Pulse Delay**

Sets the delay between the start of the first pulse and the start of the second pulse, see [Figure 7-4](#).

Remote command:

`[ :SOURce<hw> ] :PULM:DOUBle:DELay` on page 256

**7.6.3 Pulse Connector/Trigger Settings**

- ▶ To access the pulse connector/trigger settings, select "SGMA-GUI > Instrument Name > Pulse Modulation > Connector/Trigger".

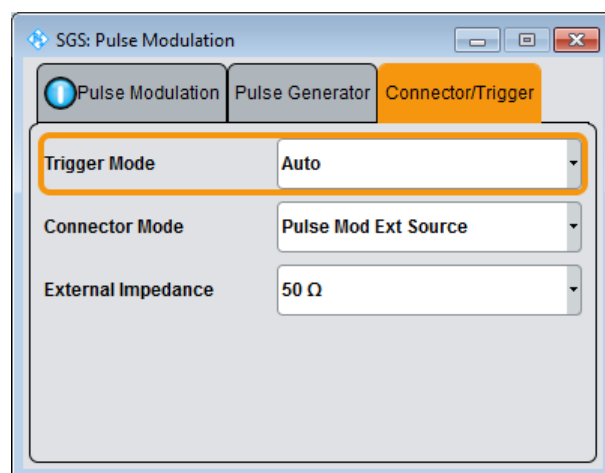

Comprises the settings necessary to configure the signal at the multi-purpose [TRIG] connector in the external trigger mode.

**Trigger Connector Mode**

Determines the signal at the input/output of the multi purpose [TRIG] connector.

"Signal Valid" Output of high signal to mark valid frequency and level settings.

"Not Signal Valid"

Output of high signal to mark the transition state when frequency and level change.

"Pulse Video Out"

Output of the internally generated pulse video (modulating) signal. The video signal level corresponds to the RF envelope.

**"Pulse Mod Ext Trigger"**

Input for an external trigger signal, used to trigger the pulse generator.

**"Pulse Mod Ext Source"**

Input for an externally provided pulse modulation signal. Used when an external pulse modulator source is provided at the connector.

Remote command:

[:CONNector:TRIGger:OMODE](#) on page 208

**Trigger Mode**

Selects between continuous pulse modulation or pulse modulation triggered by an external signal.

"Auto" Generates the modulation signal continuously.

"Ext Single" Generates the signal each time an external trigger event occurs.

"Ext Gated" Generates the signal triggered by an external gate signal.

Remote command:

[\[:SOURce<hw>\]:PULM:TRIGger:MODE](#) on page 258

**Ext. Trigger Input Slope**

Available only for "Trigger Mode > Ext Triggered "

Sets the polarity of the active slope of an applied external trigger signal.

Remote command:

[\[:SOURce<hw>\]:PULM:TRIGger:EXTernal:SLOPe](#) on page 258

**Gate Input Polarity**

Available only for "Trigger Mode > Ext Gated "

Sets the polarity of the active slope of an applied gate signal.

Remote command:

[\[:SOURce<hw>\]:PULM:TRIGger:EXTernal:GATE:POLarity](#) on page 258

## 7.7 Trigger Connector Settings

The dialog provides settings to determine the signal at the input/output of the multi-purpose [TRIG] connector.

- ▶ To access the pulse connector/trigger settings, select "SGMA-GUI > Instrument Name > Connector".

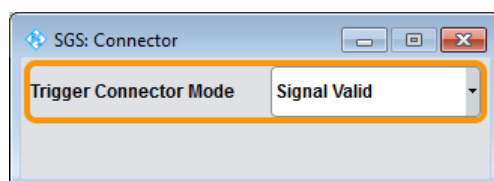

Comprises the settings necessary to configure the signal at the input/output of the multi-purpose [TRIG] connector.

#### Trigger Connector Mode

Determines the signal at the input/output of the multi purpose [TRIG] connector.

"Signal Valid" Output of high signal to mark valid frequency and level settings.

"Not Signal Valid"

Output of high signal to mark the transition state when frequency and level change.

"Pulse Video Out"

Output of the internally generated pulse video (modulating) signal. The video signal level corresponds to the RF envelope.

"Pulse Mod Ext Trigger"

Input for an external trigger signal, used to trigger the pulse generator.

"Pulse Mod Ext Source"

Input for an externally provided pulse modulation signal. Used when an external pulse modulator source is provided at the connector.

Remote command:

[:CONNector:TRIGger:OMODE](#) on page 208

## 7.8 I/Q Modulation and Signal Impairment

The R&S SGS offers I/Q modulation with external analog I/Q signals. I/Q modulation with an external analog I/Q signal is possible for the instrument equipped with frequency options R&S SGS-B106V/-B112V. The external signal is input via the I and Q connectors and transferred to the I/Q modulator.

Before the signal is fed into the I/Q modulator, the signal can be impaired. Impairment at this point along the signal flow is provided for error correction of the supplied signal or for enabling dedicated impairments. Impairments caused by the I/Q modulator are automatically corrected by the "Internal Adjustments" function.



System error correction of the I/Q modulator permits precise and repeatable measurements. The correction routine should be called in the case of temperature fluctuations of several degrees. To call the routine, select "SGMA-GUI > Instrument Name > Setup > Internal Adjustment" and execute the desired adjustment procedure.

### 7.8.1 I/Q Impairments

Signal impairments are well-defined arithmetic modifications of the data. Every data sample is modified in the same way. The purpose of adding impairments to the data

stream is to simulate frequent sources of distortions in a real signal-processing chain to generate a test signal with dirty transmitter conditions.

### 7.8.1.1 Gain and Gain Imbalance

An I/Q gain is a multiplication of all I/Q amplitudes by a common factor. The effect is equivalent to two identical I and Q gain factors. The effect of an increased gain factor in the I/Q constellation diagram is shown below.

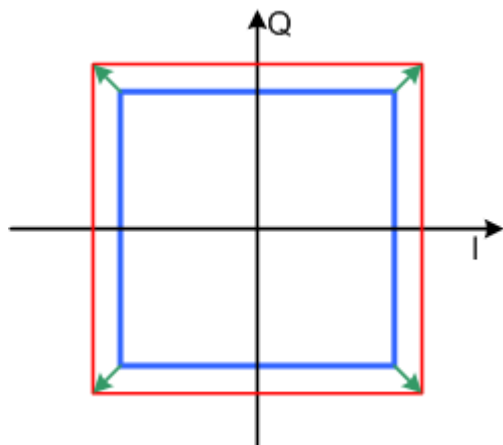

Figure 7-5: Effect of an increased amplitude in the I/Q constellation diagram

An I gain multiplies the I amplitudes by a factor, leaving the Q amplitudes unchanged. A Q gain has the opposite effect. Different I and Q gain factors result in an I/Q imbalance. This is usually due to different gains of the amplifiers in the I and Q channels of the I/Q modulator. The effect of a positive and negative gain imbalance is shown below.

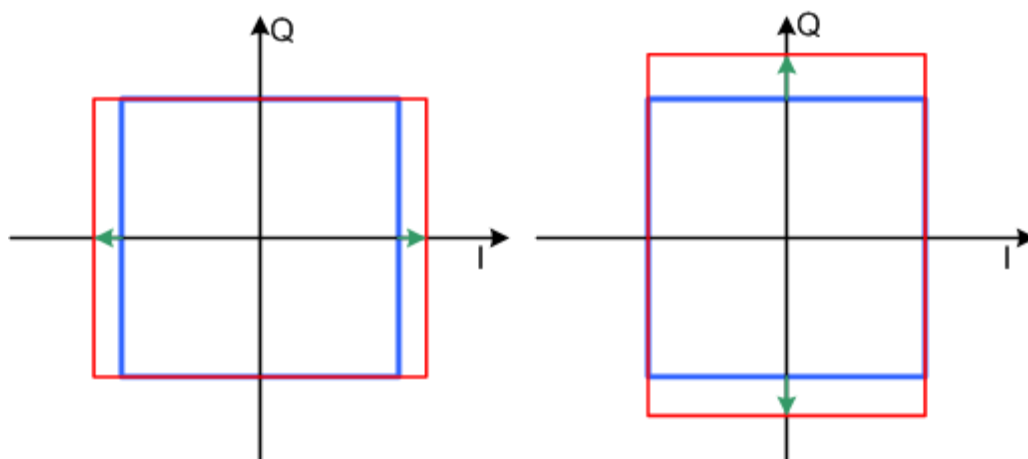

Figure 7-6: Negative gain imbalance (left) and positive (right) gain imbalance in the I/Q constellation diagram

### 7.8.1.2 I and Q Offset

An I offset adds a constant value to all I amplitudes, leaving the Q amplitudes unchanged. A Q offset has the opposite effect. A combination of I and Q values results in an I/Q offset, which is usually due to carrier feedthrough in the I/Q modulator. Possible reasons are interfering signals at the RF carrier frequency, e.g. an unsuppressed RF carrier subchannel. The effect of a positive I and Q offset in the I/Q constellation diagram is shown below.

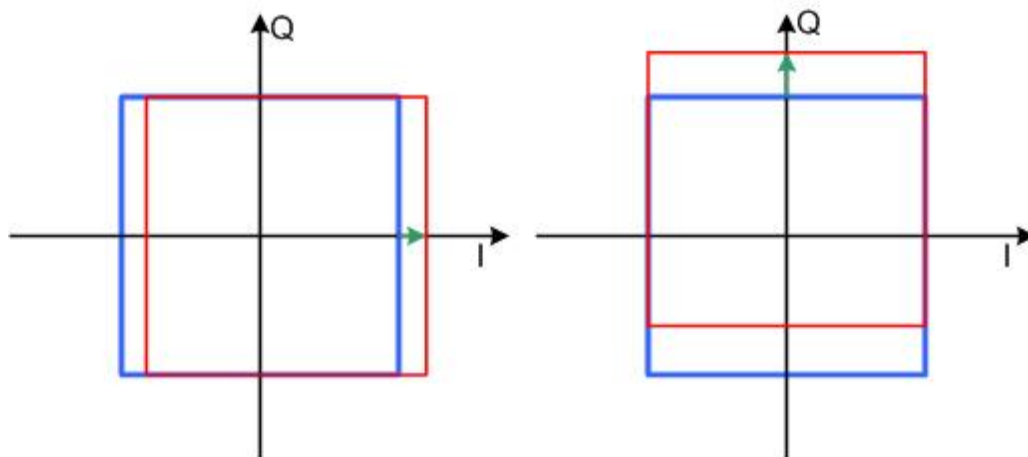

Figure 7-7: I offset (left) and Q offset (right) in the I/Q constellation diagram

### 7.8.1.3 Quadrature Offset

Changes the phase angle between the I and Q vectors from the ideal 90 degrees, while the amplitudes are maintained. A positive quadrature offset results in a phase angle greater than 90 degrees. The effect of a positive quadrature offset in the I/Q constellation diagram is shown below.

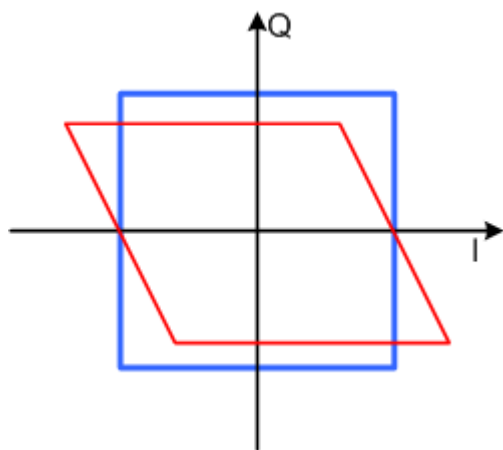
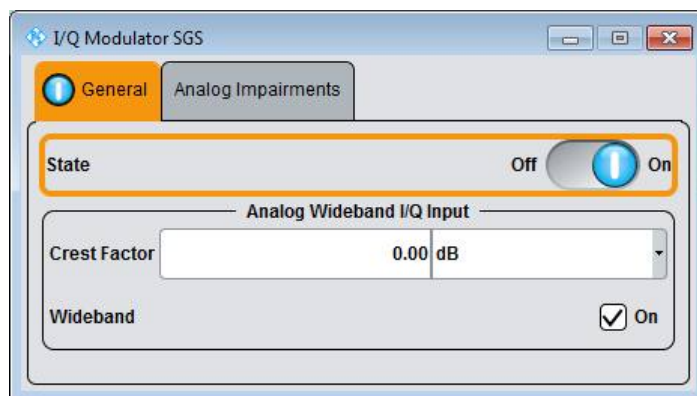

Figure 7-8: Positive quadrature offset in the I/Q constellation diagram

## 7.8.2 General I/Q Settings

- ▶ To access the settings of the I/Q modulator, select "SGMA-GUI > Instrument Name > I/Q Settings > General".



Comprises the settings for setting the state and the analog wideband I/Q input.



### Mod State

Switches the I/Q modulation on and off.

Remote command:

`[ :SOURce ] : IQ : STATe` on page 246

### I/Q Wideband

Setting mode for wideband modulation signals (higher I/Q modulation bandwidth).

The modulation frequency response of the R&S SGS in the useful bandwidth is improved at the expense of poorer harmonic suppression. This is achieved by shifting the switching frequencies of the low pass filters in the output section.

Remote command:

`[ :SOURce ] : IQ : WBSTate` on page 248

### Crest Factor

Sets the crest factor of the I/Q modulation signal.

The crest factor gives the difference in level between the peak envelope power (PEP) and average power value (RMS) in dB. This value is necessary for the generation of the correct output power at the RF output, i.e. the instrument uses the crest factor value to compensate the average power.

In vector modulation mode, the output level setting is correlated to the nominal full scale voltage at the I/Q input. If the baseband signal exhibits no constant envelope, the instrument internal level setting can be corrected by use of the crest factor value.

Remote command:

`[ :SOURce ] : IQ : CRESTfactor` on page 247

### 7.8.3 Analog Impairment Settings

- ▶ To access the settings of the I/Q modulator, select "SGMA-GUI > Instrument Name > I/Q Settings > Analog Impairments".

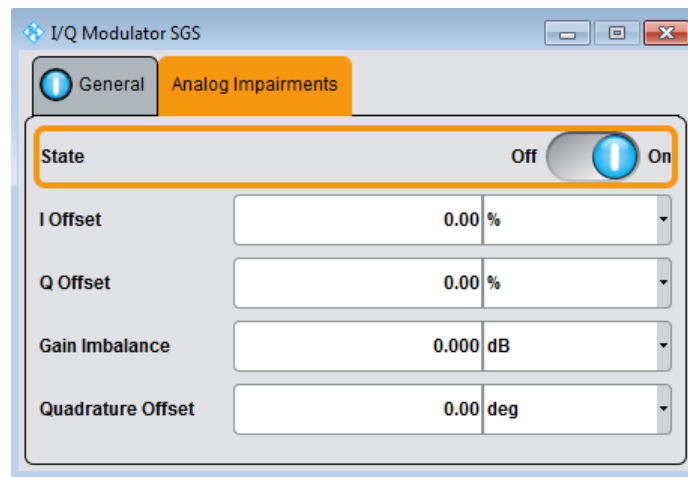

Comprises the settings like I/Q offset and quadrature offset.

#### State

Activates/deactivates I/Q impairments.

If activated, the settings for offset, gain imbalance and quadrature offset become effective.

It is indicated in the function block, if the I/Q impairment is activated.

Remote command:

`[ :SOURce ] :IQ :IMPairment [ :STATe ]` on page 247

#### Offset

Sets the carrier offset (in percent) of the amplitudes (scaled to the peak envelope power (PEP) for the I and/or Q signal component. An ideal I/Q modulator suppresses the carrier offset completely (offset = 0 percent).

For more information, see [Chapter 7.8.1.2, "I and Q Offset"](#), on page 120.

Remote command:

`[ :SOURce ] :IQ :IMPairment :LEAKage :I` on page 246

`[ :SOURce ] :IQ :IMPairment :LEAKage :Q` on page 246

#### Gain Imbalance

Sets the imbalance of the I and Q vector (see [Chapter 7.8.1.1, "Gain and Gain Imbalance"](#), on page 119).

The entry is made in dB (default) or %, where 1 dB offset is roughly 12 % according to the following:

$$\text{Imbalance [dB]} = 20 \log ( | \text{GainQ} | / | \text{GainI} | )$$

Positive values mean that the Q vector is amplified more than the I vector by the corresponding percentage. Negative values have the opposite effect.

Remote command:

`[ :SOURce ] :IQ:IMPairment:IQRatio [ :MAGNitude ]` on page 246

#### Quadrature Offset

Sets the quadrature offset (see [Chapter 7.8.1.3, "Quadrature Offset"](#), on page 120).

Remote command:

`[ :SOURce ] :IQ:IMPairment:QUADrature [ :ANGLE ]` on page 247

## 7.9 Preset

Calls up a defined instrument setup. All parameters and switching states are preset (also those of inactive operating modes). The default instrument settings provide a reproducible initial basis for all other settings. However, functions that concern the integration of the instrument into a measurement setup are not changed, e.g. reference oscillator settings.

#### Overview of the most important preset states

The following list gives an overview of the presets for the most important generator settings. The other presets can be found in the information accompanying the remote commands.

- "RF frequency" = 1 GHz
- "Reference frequency" = "Internal"; adjustment off
- "RF output" switched off
- "Modulator State" = Off

Settings that are **not affected** by the "SGMA-GUI > Instrument Name > Preset" function:

- Reference frequency settings ("Ref Oscillator" dialog)
- Power on settings ("Level" dialog)
- Network settings ("Setup" dialog)
- Password and settings protected by passwords ("Setup" dialog)
- "Eco Mode" state ("Setup > Eco Mode" dialog)



To preset the R&S SGMA-GUI itself and all configured instruments to their predefined state, use the "SGMA-GUI > File > New" function.

---

SCPI command:

`:SYSTem:PRESet` on page 205

## 7.10 Extension

Depending on the installed option, your R&S SGS generates an RF signal with frequency range up to 12.75 GHz. Some test cases, however, require even higher frequencies. A general setup would thus include an upconverter connected to the signal generator and you would have to control both the signal generator and the upconverter.

The R&S SGS equipped with one of the options R&S SGS-B112/B112V provides the build-in extension mode for controlling the R&S SGU upconverter. If you connect an R&S SGU to the R&S SGS, this upconverter acts as an extension to your instrument extending its frequency range to 20 GHz for instance. Refer to [Chapter 5.2, "Setups for Connecting an R&S SGS and an R&S SGU"](#), on page 42 for a description of the possible setups.

The extension mode provides the following advantages:

- Simplified calibration of the R&S SGU and single point of control  
In this setup, a controller does not need to access the extension, i.e. the R&S SGU, directly. Instead, the R&S SGS acts as a controller to it and depending on the required output signal parameters performs all required settings automatically. The signal generator settings of the extension are disabled for direct configuration in the R&S SGMA-GUI. However, you can still remotely control the extension using the corresponding SCPI commands.
- Extended value ranges and functionality  
The main application field of the extension mode is the extended frequency range but you can also benefit from the I/Q modulation and pulse modulation functions of the extension. For frequencies greater than 12.75 GHz, the combination of R&S SGS and R&S SGU can generate vector modulated signals even if the R&S SGS is not equipped with the required options R&S SGS-B106V/B112V.

Prerequisites and required physical connections for operation in extension mode:

- The R&S SGS is equipped with one of the options R&S SGS-B112/B112V.
- A remote PC is connected to the master instrument, the remote PC and the instrument are switched on and a connection between them is established.  
The instrument and the extension are connected via a direct remote connection or over network/switch. All interfaces (LAN, PCIe, or USB) can be used for controlling the SGU.
- The R&S SGMA-GUI or an application program is running on the remote PC.
- Signal connections between the R&S SGS and the R&S SGU are established, i.e. the connections between:
  - The [RF Out] of the R&S SGS and the [LO In] of the R&S SGU
  - For vector modulated signals, the [I Out/Q OUT] of the R&S SGU and the [I In/Q IN] of the R&S SGS
  - The [TRIG] connectors of both instruments

This section describes the manual operation via the R&S SGMA-GUI software. The remote commands required to define these settings are described in [Chapter 11.8, "EXTension Subsystem"](#), on page 209.

### To access the extension mode settings and enable the extension mode

1. Select "SGMA-GUI > Instrument Name > Extension".

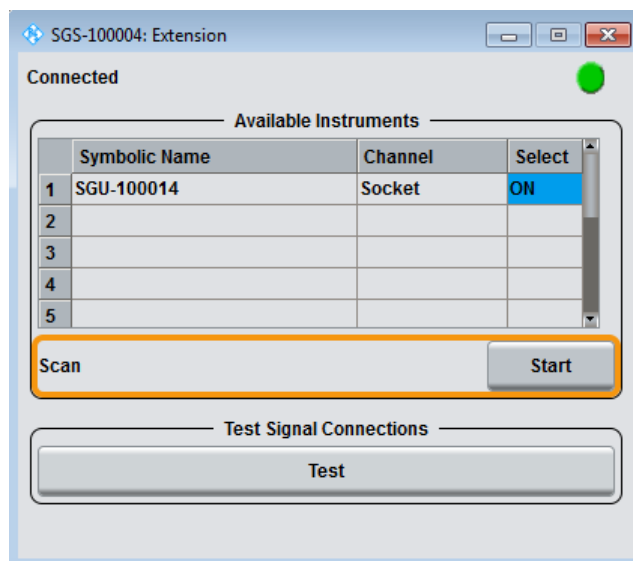

**Tip:** Steps 2 and 3 can be omitted if the R&S SGS and a single R&S SGU are connected using PCIe or USB or by a direct LAN connection. In this case, R&S SGS automatically activates the R&S SGU.

2. Trigger "Scan" to find all available instruments that can serve as an extension to the particular instrument.
3. Select an instrument from the list and set "Available Instruments > Select > On" to enable it as an extension.

A green status indicator "Connected" indicates the successfully established remote connection to the extension.

4. Select "Test Signal Connections > Test" to trigger a check of all required signal connections.

The diagram displays the connection state of the tested connections.

The R&S SGMA-GUI indicates the extended frequency range of the master instrument and the activated extension mode.

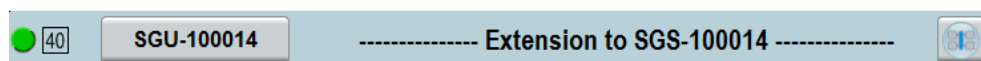

You cannot access the signal generation settings of an instrument working in extension mode. The extension is controlled via the master instrument.

To display the R&S SGU settings, click on the  button next to the instrument's name.

Select for example "SGMA-GUI > Master Instrument Name > Freq = 20 GHz", "Lev = -30 dBm" and enable "RF > State > On". The extension adopts these values and states automatically. To confirm, disable the "Extension > Available Instruments > Extension Name > Select > Off" and compare the values of the parameters "SGMA-GUI > Extension Instrument Name > Freq/Lev".

**Connected**

The connection state indicator visualizes the state of selected extension:

- Grey - the connection to the extension is not activated ("Extension > Available Instruments > Instrument# > Select > Off")
- Green - the extension is connected to the master instrument and can be manually and remotely operated
- Red - the extension is in standby or locked state, or is performing a time consuming operation

**Available Instruments**

Lists all available instruments that may serve as an extension to the R&S SGS.

Each instrument is represented by:

"Symbolic Name"

Alias name of the instrument as it is defined in the main panel of R&S SGMA-GUI.

"Channel"

Hardware channel, "Socket", "LAN", "USB" or "PCIe", used by the extension as remote control channel

"Select"

State of the remote connection to the extension. The R&S SGMA-GUI indicates an activated extension mode as follows:

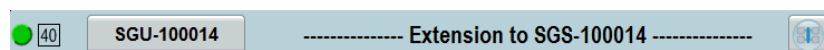

Remote command:

`:EXTension:BUSY[:STATe]?` on page 211  
`:EXTension:INSTRuments:NAME?` on page 210  
`:EXTension:INSTRuments:REMote:CHANnel?` on page 210  
`:EXTension:INSTRuments:REMote:LAN:NAME?` on page 211  
`:EXTension:INSTRuments:REMote:SERial?` on page 211  
`:EXTension:INSTRuments:SCAN[:STATe]` on page 210  
`:EXTension:REMote:STATe?` on page 210

**Scan**

Triggers a scan function and searches for instruments connected to the instrument via all the available interfaces.

Remote command:

`:EXTension:INSTRuments:SCAN[:STATe]` on page 210

**Test Signal Connections**

The "Test" function triggers a test of all signal connections between the instrument and the extension. The schematic diagram displays the required physical signal connection for the current test setup and the connection state.

A faulty connection is marked with a red line crossing the drawn blue connection line as shown in [Figure 7-9](#). If your connection is marked as faulty check whether the cables are connected properly and if the connection cables are functioning properly.

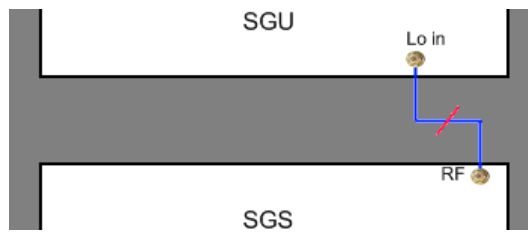

*Figure 7-9: A faulty connection between an R&S SGU and an R&S SGS*

**Note:** If your connection is marked as faulty check whether the cables are connected properly. Check also if the connection cables are functioning properly.

Remote command:

`:TEST:EXTension:CONNECTION?` on page 212

`:TEST:EXTension:CONNECTION:RF?` on page 212

## 8 General Instrument Settings and Instrument Setup

This section describes the settings which do not directly affect signal generation.

Access:

- ▶ Select "SGMA-GUI > Instrument Name > Setup" and select the required dialog.

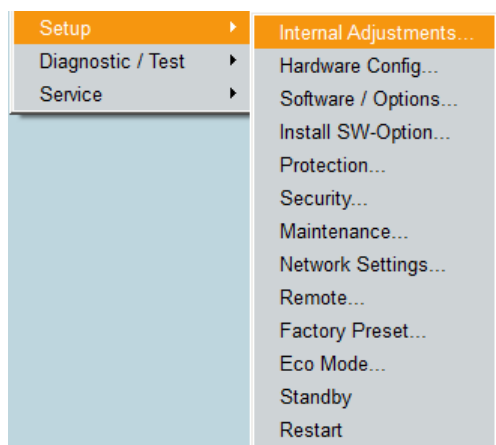

### 8.1 Internal Adjustments

The R&S SGS is accurate due to the integrated procedures for adjustments.

All internal adjustments for which no external measuring equipment is needed can be started in the "Internal Adjustments" dialog. The adjustments with external measuring equipment are described in the service manual.



Adjustment is recommended if the temperature range in which the instrument is operated changes, before all applications which require maximum level and frequency accuracy, or after enabling/disabling of the "Eco Mode" (see [Chapter 8.12, "Eco Mode"](#), on page 143).

During adjustment, a bar indicates the status of progress. If an error occurs, adjustment is terminated and an error message is output in the info line.

#### **NOTICE**

##### **Risk of invalid adjustment**

Wait until the instrument has reached its operating temperature before you start the adjustment procedure. The warm-up time is 30 minutes.

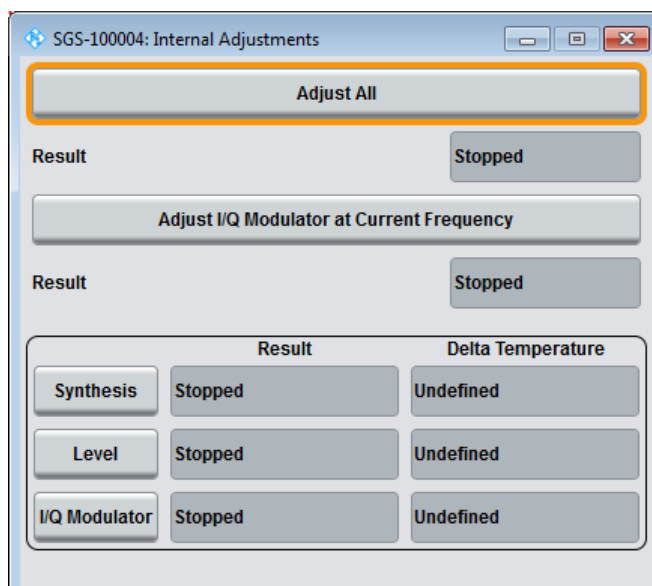

### Adjust All

Starts all internal adjustments for which no external measuring equipment is needed. The adjustments with external measuring equipment are described in the service manual.

Remote command:

`:CALibration:ALL[:MEASure]?` on page 205

### Adjust I/Q Modulator at Current Frequency

Starts the adjustment for the I/Q modulator for the currently set frequency. The I/Q modulator is adjusted regarding carrier leakage, I/Q imbalance and quadrature.

The adjustment is only possible when "RF > On" and "I/Q Mod > State > On".

Adjustment for only the set frequency is considerably faster than adjustment across the entire frequency range. An adjustment of the entire range is possible with the [I/Q Modulator](#) button of this dialog.

Remote command:

`:CALibration:IQModulator:LOCAl?` on page 206

### Synthesis

Performs all adjustments which affect the frequency.

Remote command:

`:CALibration:FREQuency[:MEASure]?` on page 206

### Level

Performs all adjustments which affect the level. The acquired correction values improve the settling time and the signal quality.

Remote command:

`:CALibration:LEVel[:MEASure]?` on page 206

**I/Q Modulator**

Starts the adjustment for the I/Q modulator for the entire frequency range. The I/Q modulator is adjusted regarding carrier leakage, I/Q imbalance and quadrature.

Remote command:

[:CALibration:IQModulator:FULL?](#) on page 206

**Delta Temperature**

Displays the difference between the current temperature and the temperature by the last performed adjustment.

**Note:** Adjustment is recommended if the temperature range in which the instrument is operated changes, before all applications which require maximum level and frequency accuracy, or after enabling/disabling of the "Eco Mode" (see [Chapter 8.12, "Eco Mode"](#), on page 143).

Remote command:

[:CALibration:LEVel:TEMPerature?](#) on page 207

[:CALibration:FREQuency:TEMPerature?](#) on page 207

[:CALibration:IQModulator:TEMPerature?](#) on page 207

## 8.2 Hardware Configuration

**Querying information about the installed assemblies**

- ▶ Select "SGMA-GUI > Instrument Name > Setup > Hardware Config".

In the "Hardware Config" dialog, the installed assemblies together with their variants and revision states can be displayed for servicing purposes.

SGS-100004: Hardware Config

Counter

Common Assembly

Assembly	Part Number	Serial Number	Revision
SGS	1416.0505k02	100004	
Controller	1416.1201.02	101265	05.02
PCI FPGA			01.17.01

RF Assembly

Assembly	Part Number	Serial Number	Revision
RfBoard	1416.1001.02	101731	09.01
Doublers	1416.1601.03	101461	04.06
RfBoard FPGA			03.72.00
OCXO	1416.2508.02	101396	02.00

The dialog is a table that lists the installed assemblies. It is divided into the sections:

- "Common Assembly"
- "RF Assembly"

### Assembly

The tables list the installed assemblies.

"Assembly" Name of the assembly

"Part Number" Part Number of the assembly

"Serial Number"

Serial number of the assembly

"Revision"

Revision state of assembly

Remote command:

`:SYSTEM:HARDware:ASSEMBly<dir>:NAME?` on page 275

`:SYSTEM:HARDware:ASSEMBly<dir>:PNUMBER?` on page 275

`:SYSTEM:HARDware:ASSEMBly<dir>:SNUMBER?` on page 276

`:SYSTEM:HARDware:ASSEMBly<dir>:REVISION?` on page 275

## 8.3 Software / Options

### Querying information about the installed options and software version

- ▶ Select "SGMA-GUI > Instrument Name > Setup > Software/Options".

The "Software/Options" dialog shows the firmware version of the instrument software and all installed hardware and software options.

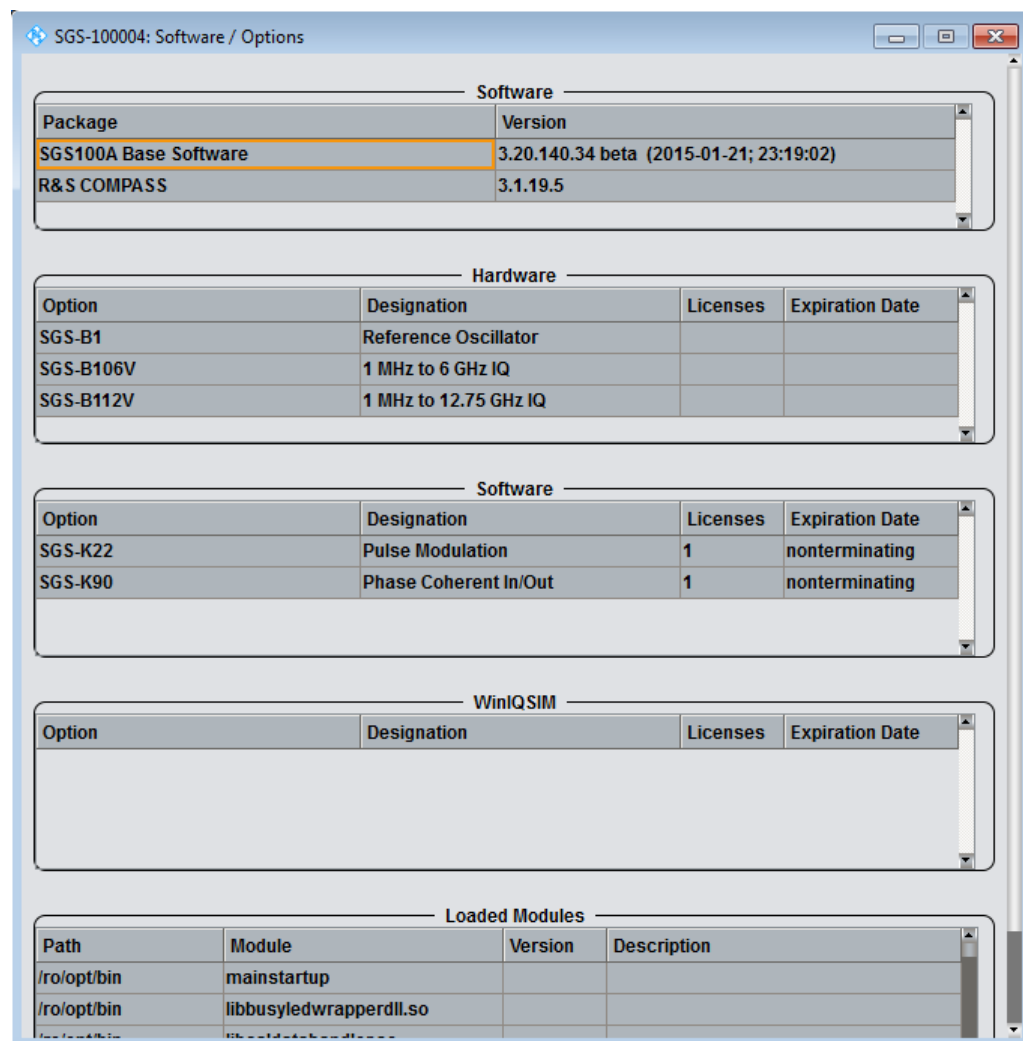

The dialog is divided into the following sections:

- "Firmware"
- "Hardware"
- "Software"
- "Loaded Modules"



Software options purchased at a later stage can be activated with a keycode. The activation code is supplied with the software option. An instruction on how to install options is described in the service manual. Most hardware options need to be installed at an authorized Rohde & Schwarz service center.

### Software

Shows the software/firmware version and the version of the software platform.

**Note:** Your instrument is delivered with the latest firmware version available. Firmware updates and the Release Notes describing the improvements and modifications are provided on the Internet at the download site of the instrument's home page. This home page always offers the latest information on your instrument, e.g. also on changes of the firmware update procedure.

### Hardware / Software/WinIQSIM

The tables in the sections "Hardware" and "Software" list the installed hardware and software options.

"Option"            Short name of the option

"Designation"    Name of the option

"Licenses"        Number of licenses

"Expiration Date"

For regular options, "Permanent" is indicated in this column. Some options are available as trial versions. This column shows their expiration date. After this date, the option is no longer available on the instrument.

Remote command:

`:SYSTem:SOFTware:OPTion<dir>:NAME?` on page 277

`:SYSTem:SOFTware:OPTion<dir>:DESignation?` on page 276

`:SYSTem:SOFTware:OPTion<dir>:LICenses?` on page 277

`:SYSTem:SOFTware:OPTion<dir>:EXPiration?` on page 276

### Loaded Modules

Section "Loaded Modules" is provided for service purposes. It lists all loaded software modules with their versions and offers a short description of each module.

### Show Open Source Acknowledgments

Accesses the list of the used open source software packages and the corresponding verbatim license texts.

## 8.4 Install SW-Options

Newly purchased software options are enabled in the "Install SW-Option" dialog. They are ready to operate after they are enabled by a key code supplied with the option.

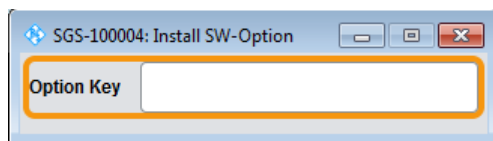

Only if the instrument is equipped with an older firmware version, a firmware update before enabling the software option may be required. The information on the valid firmware versions for the purchased software option is provided together with the option.

See:

- [Chapter 9.12, "How to Install a New Firmware Version on the Instrument"](#), on page 159 for information on how to perform firmware update
- [Chapter 9.13, "How to Activate Options"](#), on page 161 for instruction on how to install new options

The firmware update is also described in the service manual.

## 8.5 NRP Info

- ▶ To access this dialog, select "SGMA-GUI > Instrument Name > Setup > NRP Info"

Current Sensors			
Sensor Type	Serial Number	Revision	Peak
1-NRP-Z51	900001	04.18	No

### Current Sensors

Shows the sensors that are connected to the generator with information on serial number, the revision state, and some characteristic features.

## 8.6 Protection

The "Protection" dialog provides access to the unlocking of protected service functions (authorized personnel of R&S Service Departments only).

### Unlocking of protected service functions

1. Select "SGMA-GUI main panel > Instrument Name > Setup > Protection".

The "Protection" dialog provides access to the unlocking of protected service functions (authorized personnel of R&S Service Departments only).

- To deactivate the protection, the correct password has to be entered. After the instrument has been switched on, the protection levels 1 to 4 are automatically activated.

Enter "Protection Level 1 > Password > 123456".

Protection Level 1 is activated.

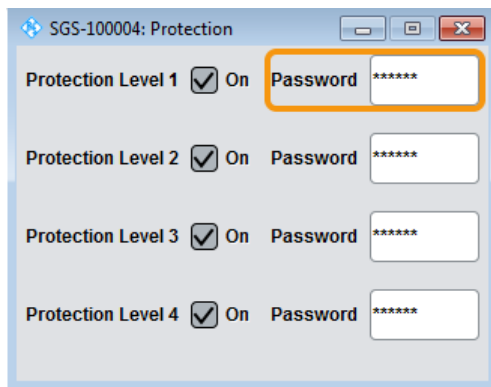

#### Protection Level / Password

"Protection Level 1" can be activated to expand the functionality of the internal adjustment. The password is 123456.

The other protection levels 2 to 4 provide access to protected service functions. Only the authorized personnel of R&S Service Departments can access these functions.

## 8.7 Security Setting

The R&S SGS employs a security concept based on user and security password. The security password is required for changing several critical settings, like performing firmware updates. Access to the passwords and mass storage security settings is provided in the "Security" dialog.

- ▶ To access the "Security" dialog, select "SGMA-GUI > Instrument Name > Setup > Security"

The menu is divided into the password sections and the security settings section. In the password section, the passwords for securing a controlled access to the instrument are defined and changed.

A change of passwords for the operating system and security password requires the entry of the old and new password and the conformation of the new password. All settings are only accepted after the "Change Password" button is pressed.



The settings of this dialog are not accessible over remote control (e.g. SCPI commands).

### Change User Password

The user name and password are required for remote access to the instrument via VNC, FTP or SAMBA.

**Note:** It is highly recommended to change the default user password before connecting the instrument to the network.

#### User Name ← Change User Password

Indicates the user name used for access to the Linux operating system and valid for VNC, FTP and SAMBA access.

#### Old Password ← Change User Password

Enter the currently used user password. The default password is "instrument".

**New Password ← Change User Password**

Enter the new user password.

**Confirm Password ← Change User Password**

Enter the new password for conformation.

The new password is only valid after the "Change Password" button is pressed.

**Change Password ← Change User Password**

Changes the password accordingly.

**Change Security Password**

**Note:** It is highly recommended to change the default security password before connecting the instrument to the network.

The security password is, for example, required when changing the status of the USB and LAN interface.

**Old Password ← Change Security Password**

Enter the currently used security password. The default password is '123456'.

**New Password ← Change Security Password**

Enter the new security password. The security password may contain decimal characters only.

**Confirm Password ← Change Security Password**

Enter the new password for conformation.

The new password is only valid after the "Change Password" button is pressed.

**Change Password ← Change Security Password**

Changes the password accordingly.

**Security Settings**

Comprises the settings for enabling and disabling the USB and LAN interfaces. The setting requires the entry of the security password and is only accepted after the "Accept" button is pressed.

**USB Device ← Security Settings**

Enable/disable the USB interface.

**Note:** The instrument does not recognize any device connected to the USB interface when the interface is disabled.

**LAN Connection ← Security Settings**

Enable/disable the LAN interface.

**Note:** It is not possible to access the instrument via LAN while the LAN connection is disabled.

An enabled LAN connection is a prerequisite for the remote control of the instrument via VNC, FTP or SAMBA.

**Security Password ← Security Settings**

Enters the password that is required to enable or to disable the settings protected by a security password. The default is '123456'.

**Note:** It is highly recommended to change the default security password before connecting the instrument to the network. To change the security password, select "SGMA-GUI > Instrument Name > Setup > Security > Change Security Password".

The settings are only accepted after the "Accept" button is pressed.

**Accept ← Security Settings**

Accept a new entry or selection and change the settings accordingly.

## 8.8 Maintenance

The R&S SGS provides a special dialog for performing some maintenance procedures, like installing firmware packages.

- To access this dialog, select "SGMA-GUI > Instrument Name > Setup > Maintenance".

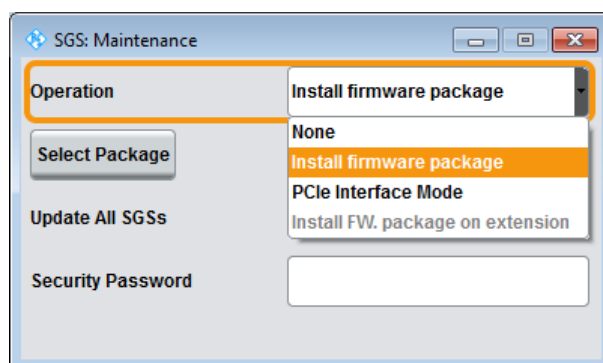
**Operation**

Selects the desired maintenance operation.

**Select Package**

Available only for "Operation > Install Firmware Package".

Selects the firmware package to be installed, see also [Chapter 9.12, "How to Install a New Firmware Version on the Instrument"](#), on page 159.

**Update All**

Available only for "Operation > Install Firmware Package".

Enable this function to perform a simultaneous firmware update on all instruments, that are in active state and are connected to this controller.

**Note:** A firmware update and the required subsequent restart and the automatically initiated internal adjustment process of the controller may be a time consuming operation.

This feature accelerates the update process and the required restart of the external PC can be executed once after the update operation of all instruments is completed.

**Security Password**

Enters the password that is required to enable or to disable the settings protected by a security password. The default is '123456'.

**Note:** It is highly recommended to change the default security password before connecting the instrument to the network. To change the security password, select "SGMA-GUI > Instrument Name > Setup > Security > Change Security Password".

The settings are only accepted after the "Accept" button is pressed.

**Accept**

Accept the selected operation and perform the required procedure.

**PCIe Interface Mode**

Sets the PCIe interface mode for the R&S SGS.

"Endpoint"            Standard mode.

"Root Com-            The mode needed for a direct PCIe connection of an R&S SGS and  
plex"                    an R&S SGU.

## 8.9 Network Settings

The instrument is equipped with a network interface and can be connected to an Ethernet LAN (local area network). The "Network Settings" dialog provides access to the network settings.

---

**NOTICE****Risk of network errors!**

Connection errors can affect the entire network.

If your network does not support DHCP, or if you choose to disable dynamic TCP/IP configuration, you must assign valid address information before connecting the instrument to the LAN.

Contact your network administrator to obtain a valid IP address.

- 
- ▶ To access this dialog, select "SGMA-GUI > Instrument Name > Setup > Network Settings".

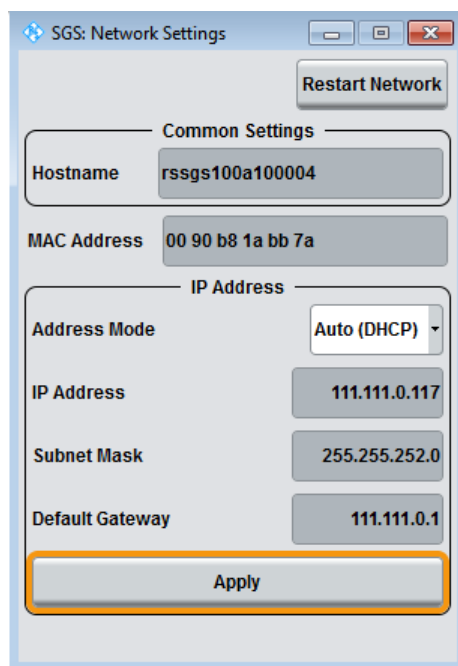

The dialog provides access to the network settings, like settings about the general network environment and specific identification of the computer in the network. The dialog also displays an indication whether the instrument is connected to the network or not.

#### Restart Network

Shuts down the network connection of the instrument and then re-establishes the connection.

This function can be used to resolve network problems.

**Note:** Only the connection of the instrument to the network restarts, the network itself is not affected.

#### Hostname

Displays the individual computer name of the instrument.

A predefined name is indicated and can be used for network connections, see [Chapter 6.4.3, "Finding Out the Default Hostname of the Instrument"](#), on page 71.

It is recommended that a connection of the instrument to the network is coordinated with the network administrator. Connection errors may affect the entire network.

Remote command:

`:SYSTEM:COMMunicate:NETWork[:COMMON]:HOSTname` on page 270

#### MAC Address

Indicates the MAC address of the network adapter.

#### Address Mode

Selects if the IP address is assigned automatically or manually.

It is recommended that a connection of the instrument to the network is coordinated with the network administrator. Connection errors may affect the entire network.

**Note:** Lost LAN connection to an instrument.

If the connection to an instrument configured to use static IP addresses is lost, press the [LAN LED] on the instrument front panel.

This resets the "Address Mode" to its default value ("Auto (DHCP)").

"Auto (DHCP)" The IP address is assigned automatically.  
The network used must support automatic assignment of IP address via DHCP or APIPA (Zeroconf) to use this function.

"Static" The IP address is assigned manually.

Remote command:

`:SYSTem:COMMunicate:NETWork:IPAdDress:MODE` on page 269

### IP Address

Displays the IP address. To enter the IP address manually, select "Address Mode > Static".

If there is manual input of the IP address, it is recommended that a connection of the instrument to the network is coordinated with the network administrator. Connection errors may affect the entire network.

Remote command:

`:SYSTem:COMMunicate:NETWork:IPAdDress` on page 269

### Subnet Mask

Displays the subnet mask. To enter the subnet mask manually, select "Address Mode > Static".

This number is used together with the IP address to identify the network segment the instrument is in.

It is recommended that a connection of the instrument to the network is coordinated with the network administrator. Connection errors may affect the entire network.

Remote command:

`:SYSTem:COMMunicate:NETWork[:IPAdDress]:SUBNet:MASK` on page 271

### Default Gateway

Displays the IP address of the default gateway. To enter the default gateway manually, select "Address Mode > Static".

This address identifies the router on the same network as the instrument that is used to forward traffic to destinations beyond the local network.

It is recommended that a connection of the instrument to the network is coordinated with the network administrator. Connection errors may affect the entire network.

Remote command:

`:SYSTem:COMMunicate:NETWork[:IPAdDress]:GATeway` on page 270

### Apply

Applies the network settings to the instrument.

## 8.10 Remote Channels

The "Remote" dialog provides access to the settings for remote control.

- ▶ To access this dialog, select "SGMA-GUI > Instrument Name > Setup > Remote".

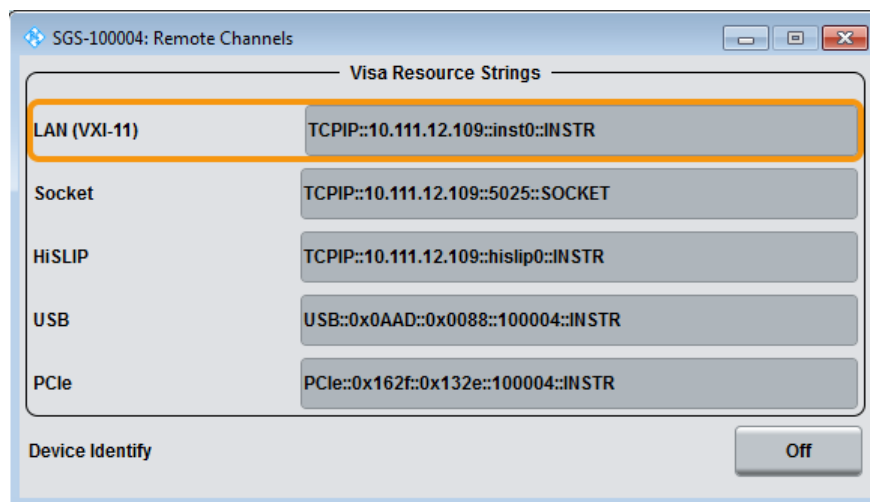

### Visa Resource Strings

Indicates the VISA resource strings used for remote control of the instrument. A separate string is provided for remote control via the different interfaces.

**Note:** For background information and description of the syntax of the VISA resource strings, refer to the description of the corresponding interface in [Chapter 10.1, "Remote Control Interfaces and Protocols"](#), on page 162.

Remote command:

- :SYSTem:COMMunicate:HISLip:RESource? on page 272
- :SYSTem:COMMunicate:NETWork:RESource? on page 271
- :SYSTem:COMMunicate:SOCKET:RESource? on page 273
- :SYSTem:COMMunicate:USB:RESource? on page 273
- :SYSTem:COMMunicate:PCIexpress:RESource? on page 272

### Device Identity

Triggers the device identification function. The [LAN] LED on the front panel of the selected instrument blinks.

See also [Chapter 6.4.4, "Bidirectional Instrument Identification"](#), on page 71.

## 8.11 Factory Preset

The "Factory Preset" dialog provides a function to reset the instrument's settings to their factory states

1. To access this dialog, select "SGMA-GUI > Instrument Name > Setup > Factory Preset".

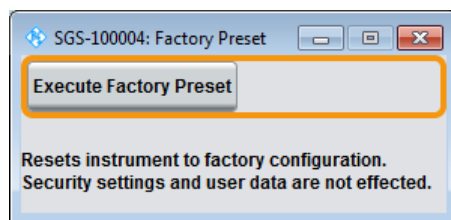

2. Select "Execute Factory Preset".

The instrument's settings are reset to their factory states. Security settings and user data are not effected.

### Execute Factory Preset

Reset the instrument's settings to their factory state.

**Note:** Because "Factory Preset" resets the "Remote Channel Settings" and "Network Settings" to the default values, executing factory preset via remote control may terminate the connection to the instrument, if these settings had been configured to values different to the default ones!

The factory preset function resets nearly all instrument settings. In addition to the regular preset, a "Factory Preset" resets also the following values:

- Power on settings ("Level" dialog)
- Network settings including hostname ("Setup > Network Setting" dialog)
- Remote Channel settings ("Setup > Remote Channel" dialog)
- Eco Mode state ("Setup > Eco Mode" dialog)

To maintain security, password settings and all settings protected by these passwords like disabled USB and LAN connections are not changed.

Not affected by the "Factory Preset" are also user data, lists or instrument settings files, created, for example, with the "File Save As" function.

Remote command:

:[SYSTem:FPRreset](#) on page 205

## 8.12 Eco Mode

This energy saving mode is available only for instruments equipped with optionR&S SGS-B112/B112V.

- ▶ To access this dialog, select "SGMA-GUI > Instrument Name > Setup > Eco Mode".

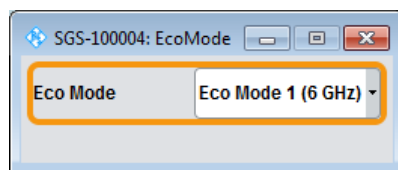

With enabled "Eco Mode 1" the doubler stage in a 12.75 GHz instrument is permanently switched off to reduce power consumption and the maximum frequency is limited to 6 GHz. An enabled "Eco Mode" is indicated by a green coloring of the frequency range in the R&S SGMA-GUI.

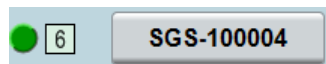

## NOTICE

### Risk of invalid adjustment after changing the Eco Mode

The switching off and on of the doubler stage changes the thermal conditions in the instrument.

In order to achieve correct adjustment of the instrument, make sure that the instrument is warm before performing adjustments. The warm-up time is 30 minutes.



### Performing adjustment in eco mode

The instrument performs the internal adjustment within the currently active frequency range, i.e. up to 6 GHz for enabled mode "Eco Mode 1". The correct alignment of the parameters outside of the current active frequency range is not guaranteed. A subsequent readjustment for the total frequency range of the instrument is recommended.

The state of this parameter is not affected by an instrument "Preset". This parameter is influenced only by the [Factory Preset](#).

SCPI command:

:SYSTem:EMODE on page 266

## 8.13 Standby and Restart

See [Chapter 9.9, "How to Switch between the Operating States"](#), on page 156.

## 8.14 Diagnostic and Tests

This section describes the settings provided for diagnostic and test purposes.

### 8.14.1 Self-test

1. To access this dialog, select "SGMA-GUI > Instrument Name > Diagnostic Tests > Self-test".

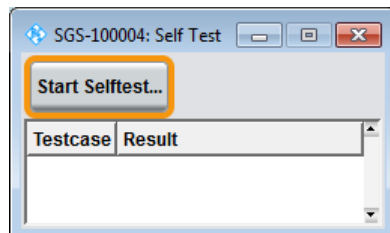

2. To trigger a self-test, select "Self-test".

Performs a self-test on all installed hardware options.

The result of the self-test, succeeded or failed, is displayed. The list of the numeric results of the performed test cases is protected by protection level 2.

SCPI command:

`:TEST:ALL:START` on page 278

`:TEST:ALL:RESult?` on page 278

### 8.14.2 Keyboard Tests

Access:

- ▶ Select "SGMA-GUI > Instrument Name > Diagnostic Tests > Keyboard Test".

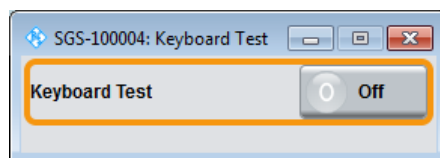

Use this function to check the proper operation of all front panel elements.

If "Keyboard Test" is enabled, all front panel LEDs except the [POWER ON] are orange.

The exact test procedure is described in the service manual.

SCPI command:

`:TEST:KEYBoard[:STATe]` on page 278

## 8.15 External Adjustments

The external adjustment is a protected service procedure, that requires a Protection Level 2 password. The exact test procedure is described in the service manual.

Access:

1. Select "SGMA-GUI > Instrument Name > Protection" and enter the Protection Level 2 password.  
(See "[Unlocking of protected service functions](#)" on page 134)
2. Select "SGMA-GUI > Instrument Name > Service > External Adjustments".

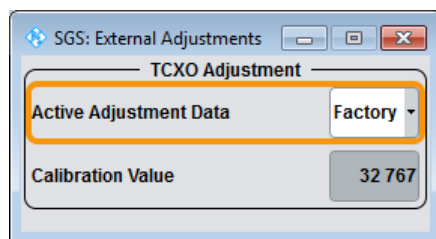

Depending on the installed options, the R&S SGS is equipped with a TCXO or OCXO reference oscillator. The reference oscillator is factory calibrated to a specific calibration value. In the external adjustment dialog, you can select a different (custom) calibration value.

### Active Adjustment Data

Selects whether the factory provided or a custom defined calibration value is used to adjust the reference oscillator.

Remote command:

[:CALibration:ROSCillator:DATA:MODE](#) on page 207

### Calibration Value

Sets a user definable calibration value.

The permanent storage of this value in the instrument's memory is a password protected function. The exact test procedure is described in the service manual.

This parameter is restored to its permanently stored value by "Preset" and instrument restart.

Remote command:

[:CALibration:ROSCillator\[:DATA\]](#) on page 208

## 9 Performing Configuration Tasks

This section provides a general explanation on how to operate the instrument manually via the R&S SGMA-GUI software.

We assume, that the R&S SGS is connected to a remote PC. The R&S SGMA-GUI software has to be installed on this remote PC and the instrument has to be added to the list of "Available Instruments".



For information on how to fulfill these requirements, refer to:

- [Chapter 2.3.2.1, "Connecting the Instrument to the Network"](#), on page 25
- [Chapter 2.3.1, "Installing the R&S SGMA-GUI Software"](#), on page 23
- [Chapter 2.3.2.3, "Automatically Adding Instruments to the SGMA-GUI"](#), on page 27

### General workflow

The general workflow for generating a signal with the R&S SGS comprises the following main steps:

1. Decide whether you want to generate a CW or an I/Q modulated signal.  
See [Chapter 9.1, "How to Generate an I/Q Modulated Signal"](#), on page 147.
2. Select the operating mode.  
See [Chapter 9.3, "How to Enable a Baseband Bypass Mode"](#), on page 151.
3. Configure the reference and local oscillator settings.  
See [Chapter 9.4, "How to Configure the Reference Oscillator Source"](#), on page 152 and [Chapter 9.5, "How to Configure the Local Oscillator \(LO\) Coupling Source"](#), on page 153.
4. Adjust the frequency, level and I/Q settings, for example, to optimize performance or to add impairments to the generated signal (see [Chapter 9.11, "How to Optimize Performance"](#), on page 158).

### 9.1 How to Generate an I/Q Modulated Signal

The instrument is manually operated via the R&S SGMA-GUI software.



The I/Q Modulator requires the hardware option R&S SGS-B106V and for operation up to 12.75 GHz also the hardware option R&S SGS-B112V.

An example of how to configure the instrument to generate a continuous wave (CW) signal is provided in [Chapter 4, "First Steps with the Instrument"](#), on page 36.

### To generate an I/Q modulated signal

1. Connect the test equipment. Provide the external analog signal to be modulated at the I and Q connectors of the instrument.

The [Figure 9-1](#) shows an example of the test setup. A signal generator, e.g. R&S AFQ100B is used as a source of the external analog signal. The R&S signal generator provides its internal reference signal to the R&S SGS and the connected signal analyzer, e.g. the R&S FSW.

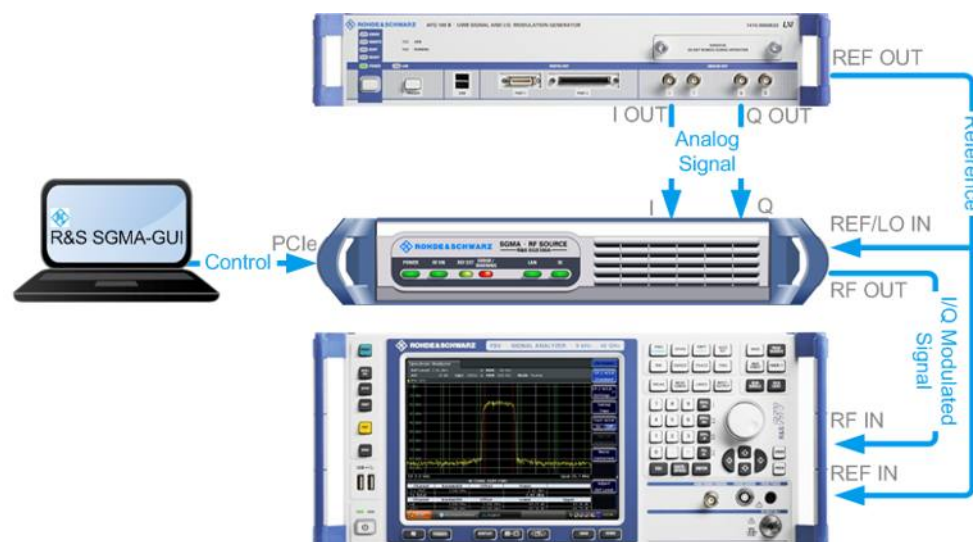

**Figure 9-1:** Example of the setup

**Tip:** Refer to the user manual of the R&S signal generator and the R&S signal analyzer for information on how to configure the corresponding instrument.

2. Select "SGMA-GUI main panel > Instrument Name > Reference Oscillator > Ext" and adjust the settings as required.
3. Select "SGMA-GUI main panel > Instrument Name > Frequency/Phase > LO Coupling Source > Int".

**Tip:**

For detailed description on how to select the reference frequency source and the LO coupling source, refer to:

- [Chapter 9.4, "How to Configure the Reference Oscillator Source"](#), on page 152 and
- [Chapter 9.5, "How to Configure the Local Oscillator \(LO\) Coupling Source"](#), on page 153.

4. In the "Frequency/Phase" dialog, configure the frequency settings.
5. Select the "SGMA-GUI > Instrument Name > Level > RF Level > Level" and set the "RF Level".  
In the same dialog, configure the further "Level" and "Power-On" settings.
6. Select the "SGMA-GUI main panel > Instrument Name > I/Q settings > Analog Impairments" and enable I/Q impairments.

In the "I/Q settings >General" dialog, set "State > On" to enable the I/Q modulator.

7. Select "SGMA-GUI main panel > RF > On" or press the [RF ON] key on the front panel of the instrument.

The [RF ON] key is green.

The I/Q modulated signal is output at the RF connector of the instrument.



#### How to generate an I/Q modulated signal with higher RF?

If the R&S SGS is equipped with one of the options R&S SGS-B112/B112V, you can connect an extension, an R&S SGU, to it and thus extend the frequency range of the generated I/Q signal up to 40 GHz.

Refer to [Chapter 9.2, "How to Generate I/Q Signals with an R&S SGS and an R&S SGU Upconverter"](#), on page 149 for more information.

---

## 9.2 How to Generate I/Q Signals with an R&S SGS and an R&S SGU Upconverter



Options R&S SGS-B112V and R&S SGU-B120V/-B140V are required for the I/Q modulation.

---

#### To generate an I/Q modulated signal with higher frequency

In this example, the R&S SGU acts as an extension to the R&S SGS extending its frequency range to 40 GHz.

The [Figure 9-2](#) shows an example of the test setup.

## How to Generate I/Q Signals with an R&amp;S SGS and an R&amp;S SGU Upconverter

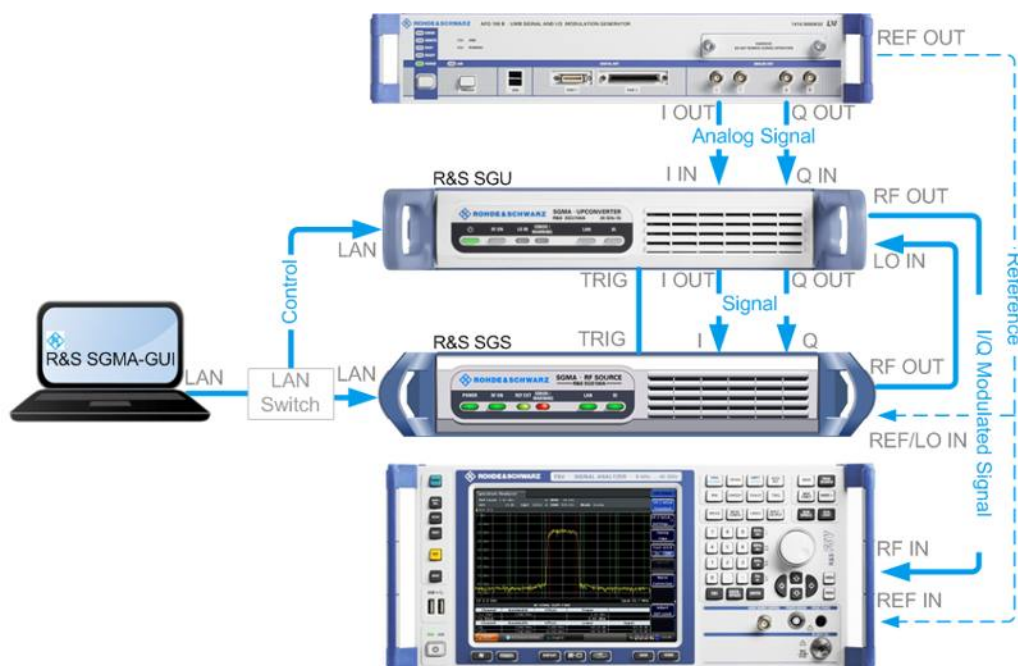

Figure 9-2: Example of the test setup



For higher setting/ measuring speeds, use a PCIe switch and PCIe connections.

If a common reference frequency is required, use the internal reference signal of the signal generator and provide it to the R&S SGS and the connected signal analyzer, e.g. the R&S FSW.

1. Connect the test equipment as shown on [Figure 9-2](#):
  - a) Connect the R&S SGS, the R&S SGU and the controller to a LAN switch.
  - b) Connect the [I/Q OUT] of the base band signal source to the [I/Q IN] of the R&S SGU.
  - c) Connect the [I/Q OUT] of the R&S SGS to the I and Q connectors of the R&S SGS.
  - d) Connect the [RF OUT] of the R&S SGS to the [LO IN] of the R&S SGU.
  - e) Connect the [TRIG] connectors of the R&S SGS and the R&S SGU.
  - f) Connect the [RF OUT] of the R&S SGU to the [RF IN] of the signal analyzer.
2. Select "SGMA-GUI main panel > R&S SGS > Extension".
 

**Tip:** Steps 3 to 5 can be omitted if the R&S SGS and a single R&S SGU are connected using PCIe or USB or by a direct LAN connection. In this case, the R&S SGS automatically activates the R&S SGU.
3. Press the ID key on the front panel of the R&S SGU (only required if the components are connected via a company network).
4. In the "Extension" dialog, trigger "Scan".

The scan function finds out the connected R&S SGU.

5. Select the R&S SGU from the list and set "Available Instruments > Select > On" to enable it as an extension.

A green status indicator "Connected" indicates the successfully established remote connection to the extension.

6. Select "Test Signal Connections > Test" to trigger a check of all required signal connections.

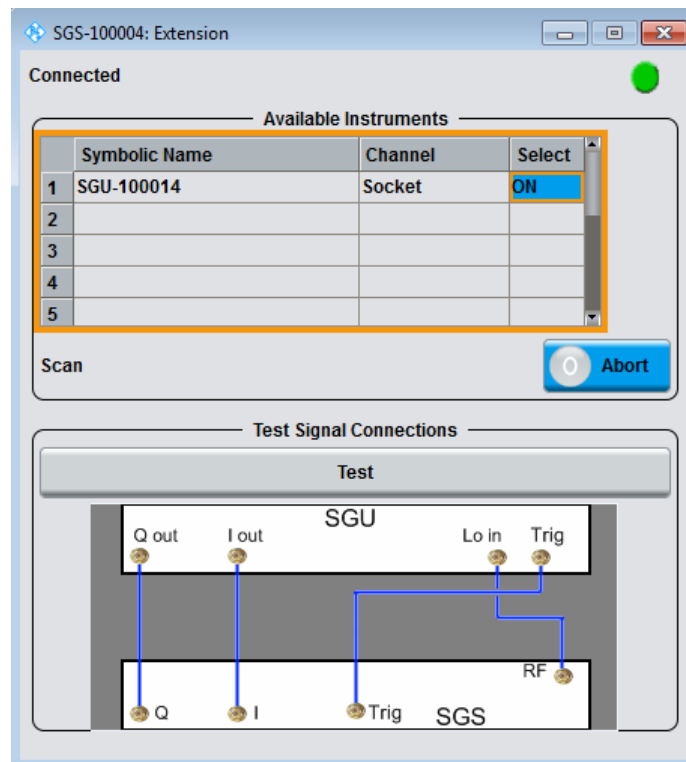

The diagram displays the connection state of the tested connections.

7. Select "SGMA-GUI > R&S SGS > Freq = 20 GHz", "Lev = -30 dBm" and enable "RF > State > On".

The extension adopts these values and states automatically. Generated is an I/Q signal with "RF = 20 GHz" and "Level = -30 dBm".

### 9.3 How to Enable a Baseband Bypass Mode

1. Provide an external analog signal at the I or Q connector or on both at the rear of the instrument.  
Refer to [Figure 5-9](#) for visualization of the signal flow.
2. Select "SGMA-GUI > Instrument Name > Operation Mode > Baseband Bypass".

Some instrument's functions like "Frequency" and I/Q settings are disabled.

3. Select "SGMA-GUI > Instrument Name > Level > RF Level" and adjust the level of the output signal.
4. Set "SGMA-GUI > RF > On" or press the [RF ON] key on the front panel of the instrument to enable the output of the generated signal at the RF connector.

The [RF ON] key is green.

The fed signal is amplified with the selected value and output at the RF connector of the instrument.

## 9.4 How to Configure the Reference Oscillator Source

### To use the internal reference frequency source

1. To enable the instrument to use its internal reference frequency source, perform one of the following:
  - a) Select "SGMA-GUI main panel > Ext Ref Off".
  - b) Select "SGMA-GUI > Instrument Name > Reference Oscillator > Source > Int".
2. In the "Reference Oscillator" dialog, set the "REF/LO Out > REF".

The "Output Frequency" can be configured to either 10 MHz or 1 GHz.

The instrument uses the internal reference signal. The [REF EXT] LED at the front panel of the instrument is off.



To output the reference frequency (internal or external) at the REF/LO OUT connector of the instrument, select "Reference Oscillator > REF/LO Output > REF".

### To use an external reference frequency source

To improve measurement accuracy, it is advisable to provide an external reference frequency to all the instruments in the test setup or to distribute the internal reference signal of the signal generator to the remaining instruments.

1. Provide the signal of an external reference frequency source to the REF/LO IN connector of the instrument.
2. To enable the instrument to use the external reference frequency source, perform one of the following:
  - a) Select "SGMA-GUI main panel > REF > Ext Ref On".
  - b) Select "SGMA-GUI > Instrument Name > Reference Oscillator > Source > Ext".

3. In the "Reference Oscillator" dialog, set the parameter "Ext. Ref. Input Frequency" to the value of the fed external reference frequency.

Now, the instrument uses an external reference signal. The green [REF EXT] LED at the front panel of the instrument indicates that the instrument is synchronized to the external reference signal.



If the instrument is configured to use an external reference signal but no signal is fed in at the REF/LO IN connector, the [REF EXT] LED on the front panel of the instrument is red and an error message is displayed in the "Info" line.

## 9.5 How to Configure the Local Oscillator (LO) Coupling Source

The R&S SGS can use two frequency sources for the carrier frequency (LO signal) of the I/Q modulator, an internal and an external one. The first possibility is to use the output signal of the internal synthesizer. If an external LO signal is provided at the REF/LO IN connector, this signal can alternatively be directly routed to the LO input of the I/Q modulator.

### To use an external LO source

1. Provide the signal of an external LO source to the REF/LO IN connector of the instrument.

**Note:** The local oscillator input/output requires the additional software option R&S SGS-K90.

2. Select "SGMA-GUI > Instrument Name > Frequency/Phase > LO Coupling Source > Ext".

**Tip:** When you select "Source > Ext", the icon **LO Scr Ext** appears in the R&S SGMA-GUI.

The signal provided by the external frequency source is directly routed to the input of the I/Q modulator and used as carrier frequency.

### To use the internal LO source

- ▶ Select "SGMA-GUI > Instrument Name > Frequency/Phase > LO Coupling Source > Int".

The output signal of the internal synthesizer is used.

## 9.6 How to Define the Signal at the REF/LO OUT Connector

The reference oscillator and the LO use the same [REF/LO IN] connector. Hence, it is not possible to use both an external reference source and an external LO source signal at the same time.

The signal at the [REF/LO OUT] connector also depends on the selected reference oscillator and LO sources. The following table gives an overview of this dependency.

**Table 9-1: Selection available at the REF/LO OUT connector depending on the LO and reference oscillator sources**

Ref. oscillator source	LO coupling source	
	Int	"Ext"
"Int"	"OFF/REF/LO"	"OFF/LO"
"Ext"	"OFF/REF/LO"	Combination not possible

### To define the signal at the REF/LO OUT connector

1. In the "Frequency / Phase > Local Oscillator (LO) Coupling" dialog, select the "LO Source" as required.
2. In the "Reference Oscillator" dialog, select the "Ref. Oscillator Source" as required.
3. In the "Frequency / Phase > Local Oscillator (LO) Coupling" dialog, set the "REF/LO Output".  
Consider the dependencies, see [Table 9-1](#).

## 9.7 How to Connect and Configure Instruments for Optimum Phase Coherence

Using the LO input/output connectors, two or more instruments can be coupled to achieve optimum phase coherence between their RF output signals. The first instrument in the chain delivers the LO signal at the [REF/LO OUT] connector to the [REF/LO IN] connector of second instrument. If necessary, more instruments can be connected in the same way. The first instrument is set such that the internal synthesizer generates the system LO frequency. In all following instruments, the internal synthesizer is switched off and the LO signal from the [REF/LO IN] connector drives the I/Q modulator or the CW path.

### To connect the instruments

1. Connect the instruments as a daisy chain (see [Figure 9-3](#)), i.e. connect the [REF/LO IN] connector of each further instrument to the [REF/LO OUT] connector of the previous one.
2. Optionally, provide an external reference signal for the first instrument.

- Avoid unnecessary cable lengths and branching points.

Refer to [Figure 9-3](#) for an example of how to connect two instruments for achieving phase coherence. The configuration can be extended to further instruments.

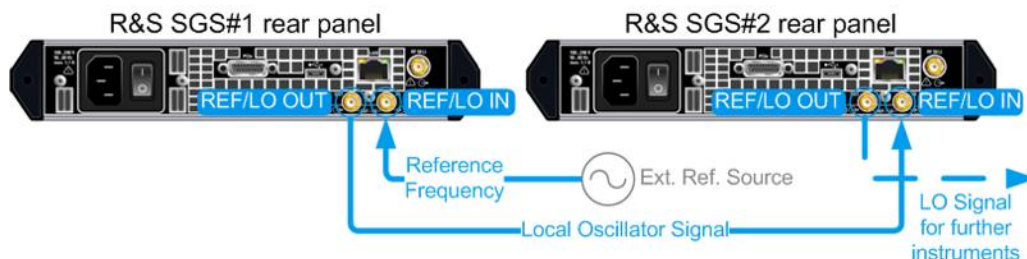

Figure 9-3: Example of a setup: LO coupling

#### To configure the first instrument in the chain

- In the "Frequency / Phase > Local Oscillator (LO) Coupling" dialog, select "LO Source > Internal".
- In the "Frequency / Phase > Local Oscillator (LO) Coupling" dialog, select "REF/LO Output > LO".
- If an external reference frequency is used, select "SGMA-GUI > Instrument Name > Reference Oscillator > Source > External".

#### To configure next instruments

- In the "Frequency / Phase > Local Oscillator (LO) Coupling" dialog, select "LO Source > External".
- In the "Frequency / Phase > Local Oscillator (LO) Coupling" dialog, select "REF/LO Output > LO".

## 9.8 How to Restore the LAN Connection to an Instrument

- ▶ If the LAN connection to an instrument configured to use a static IP address is lost, press the [LAN LED] on the instrument's front panel for more than 3 seconds to reset the LAN settings and to set the "Address Mode" on page 140 to DHCP.

Provided the network supports automatic assignment of IP address, new IP address is automatically assigned to the instrument.

## 9.9 How to Switch between the Operating States

The [Figure 9-4](#) gives an overview of the operating states of the instruments and how to trigger the switch-over between them.

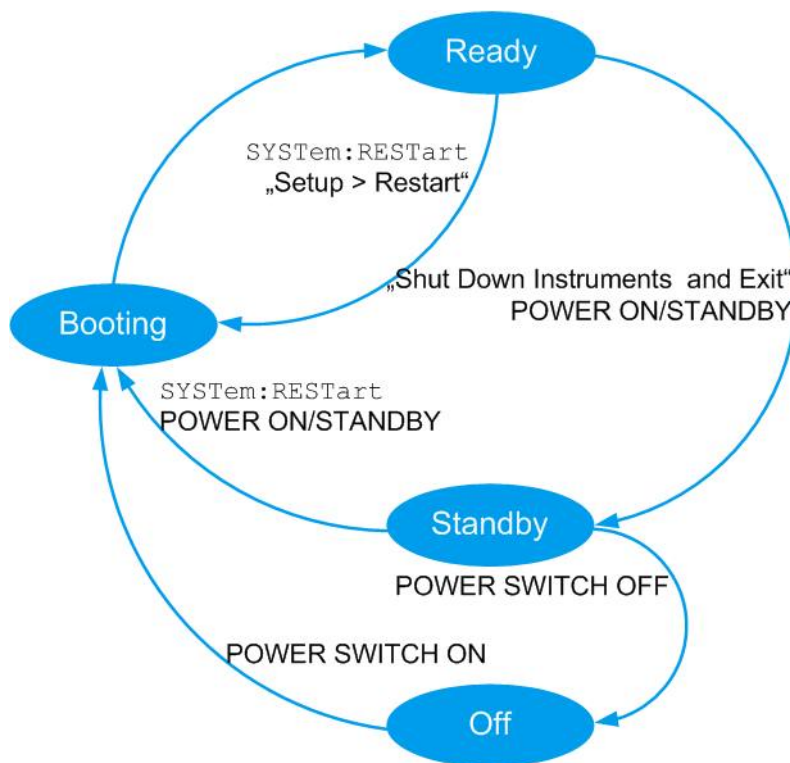

**Figure 9-4: Operating states**

:REStart, :STANdbY = SCPI commands  
 "Setup > Standby", "Setup > Restart", "Shut Down Instruments and Exit" = R&S SGMA-GUI controls  
 POWER ON/STANDBY, POWER SWITCH ON/OFF = Hardkey controls on the front/rear panel of the instrument

The [Table 9-2](#) provides a short description of the operating states and their indication.

**Table 9-2: Indication of the operating states**

Operating state	Description	Indication
Off	The instrument is shut down.	All LEDs on the front panel of the instrument are off.
Booting	The instrument boots the operating system and starts the instrument firmware. If the previous session was terminated regularly, the instrument uses the last setup with the relevant instrument settings.	The green [POWER ON /STAND BY] key blinks.

Operating state	Description	Indication
Standby	The standby power mode keeps the power switch circuits and the remote control system active. In this state, it is safe to switch off the AC power and disconnect the instrument from the power supply.	In the R&S SGMA-GUI, the status indicator in front of the instrument name is red. The orange [POWER ON /STAND BY] key is on.
Ready (normal operation)	The instrument is ready for operation. All modules are power-supplied.	In the R&S SGMA-GUI, the status indicator in front of the instrument name is green. The green [POWER ON /STAND BY] key is on.

### To switch the instrument to standby state

- ▶ Use one of the following:
  - a) On the remote PC, select "SGMA-GUI > Instrument Name > Setup > Standby".
  - b) Press the [POWER ON /STAND BY] key on the front panel of the instrument.
  - c) Send the SCPI command:

```
:SYSTem:REBoot
```

The current instruments settings are automatically stored. The instrument switches to a power-saving mode.

In the R&S SGMA-GUI, the standby state is indicated by the red state symbol in front of the corresponding instrument's name, on the front panel, by the orange [POWER ON /STAND BY] button.

The instrument can still be remote controlled.

### To return the instrument from standby to ready state

- ▶ Use one of the following:
  - a) On the remote PC, select "SGMA-GUI > Instrument Name > Setup > Restart".
  - b) Press the orange [POWER ON /STAND BY] key on the front panel of the instrument.
  - c) Send the SCPI command:

```
:SYSTem:REStArt
```

The instrument loads the last setup with all instrument settings, switches to ready state and is ready for normal operation.

In the R&S SGMA-GUI, the ready state is indicated by the green state symbol in front of the instrument's name.

On the front panel, the ready state is indicated by the green [POWER ON /STAND BY] button.

### To switch all connected instruments to standby state and close the R&S SGMA-GUI

- ▶ In the R&S SGMA-GUI main panel, select "File > Shut down instruments and exit".  
The R&S SGMA-GUI quits and switches the connected instruments to standby state.



For description on how to terminate work and shut down the instrument regularly, refer to [Chapter 2.1.5, "Switching the Instrument On and Off"](#), on page 19.

## 9.10 How to Use Computer Names

If there is a name server in the network, alternatively to the IP address each PC or instrument connected in a LAN can be accessed via an unambiguous computer name. Each instrument is delivered with an assigned computer name, but this name can be changed.



For instruction on how to find out the default computer name, refer to [Chapter 6.4.3, "Finding Out the Default Hostname of the Instrument"](#), on page 71.

### To query and change a computer name



To avoid violations and to make use of the easy identification provided by the computer name, it is recommended to keep the default hostname unchanged.

1. Open "SGMA-GUI > Instrument Name > Setup > Network Settings" dialog.  
The computer name is displayed under "Hostname".
2. Select "SGMA-GUI > Instrument Name > Setup > Protection" and enable the "Protection Level 1".  
The parameter "Hostname" in the "Network Settings" dialog is now enabled for configuration.
3. Change the "Hostname".
4. Press the [POWER ON /STAND BY] key to restart the instrument.  
**Note:** The "Factory Preset" function restores the factory value of the parameter "Hostname".

## 9.11 How to Optimize Performance

In its (factory) preset state, the instrument uses predefined frequency and level setting designed for best performance. The predefined settings, e.g. the "Level modes" "Auto" and "Normal", ensure that the instrument automatically selects the optimal settings according to the configured RF frequency and level.

However, in some special application cases it might be necessary to choose different settings or to optimize the signal for the particular application. This section describes instructions on how to achieve that.



### Restoring the default settings

Use the "R&S SGMA-GUI main panel > Instrument name > Preset" or the "R&S SGMA-GUI main panel > Instrument name > Setup > Factory Preset" function to return the instrument to its predefined state.

For information on how to adjust the quality characteristics of the RF output signal, i.e. to optimize the quality characteristics of RF output signal, refer to [Chapter 7.5, "Level and Power-On Settings"](#), on page 87.

For information on how to adjust the reference oscillator, e.g. to allow the frequency of the internal reference oscillator to be impaired, refer to [Chapter 7.4, "Reference Oscillator"](#), on page 84.

## 9.12 How to Install a New Firmware Version on the Instrument

You can update the firmware of the R&S SGS .

### Firmware installation through the R&S SGMA-GUI



If an update to a new firmware version is required for both the R&S SGMA-GUI and the instrument, it is mandatory that the new instrument's firmware is installed before the update of the R&S SGMA-GUI to the new version.

1. Select "SGMA-GUI main panel > Instrument Name > Setup > Maintenance > Operation > Install firmware package".
2. Press "Select Package" and navigate to the directory the new firmware is stored in.
3. If several instruments have to be updated to new firmware version, enable the feature "Update All " to accelerate the update process.

All instruments that are in active state and are connected to this controller are updated simultaneously.

4. Enter the "Security Password".
5. Confirm the update with "Accept".

The software transfers the firmware file and automatically starts the update procedure. During the update, the message "Updating Firmware" is displayed in the "Info" line. The update process is indicated by an LED running light.

**Note:** The update procedure requires a restart of the instrument. The restart is performed automatically. The instrument is not accessible during that time.

6. Wait until the message "Updating Firmware" disappears and the update is completed.

The green [POWER ON /STAND BY] LED is on.

**Tip:** Calibration error. If the "Info" line shows the message "Calibration Error", select "SGMA-GUI main panel > Instrument Name > Setup > Internal Adjustments > Adjust All" to trigger internal adjustment.

7. If necessary, install the new R&S SGMA-GUI.  
For detailed description, refer to [Chapter 2.3.1, "Installing the R&S SGMA-GUI Software"](#), on page 23
8. If the instrument and the controller/PC are connected over the PCIe interface and the external PC does not support hot-plugging, restart the external PC.

### Firmware update through a session control protocol (SCP)



If an update to a new firmware version is required for both the R&S SGMA-GUI and the instrument, it is mandatory that the new instrument's firmware is installed before the update of the R&S SGMA-GUI to the new version.

---

1. Connect the R&S SGS and a Windows PC to the same network.
2. On the PC, open a windows explorer window.
3. To connect to the R&S SGS, enter the name of the instrument or its IP address in the windows taskbar.
4. Enter the user name and password to connect to the R&S SGS. The default user name is *instrument* and the password is *instrument*.  
A folder opens, containing the `share` and the `update` folder.
5. Open the `update` folder and copy the new firmware update file in it.  
The update starts automatically.



### Unsuccessful or erroneous firmware update

An erroneous or unsuccessful installation of firmware update package is indicated by a combination of one orange and red LEDs on the front panel.

Refer to the service manual for a description of the displayed error code or contact the customer support center.

---

## 9.13 How to Activate Options



A firmware update before the activation of the SW option may be required.

Refer to the description of the SW option for the required firmware version.

See also [Chapter 9.12, "How to Install a New Firmware Version on the Instrument"](#), on page 159 for instruction on how to update the firmware version.

1. Select "SGMA-GUI main panel > Instrument Name > Setup > Install SW-Options".
2. Select "Option Key" and enter the key code delivered with the new option.

The new option is now enabled and ready for operation.

## 9.14 How to Manually Set a PCIe Direct Connection between an R&S SGS and an R&S SGU

To build a direct PCIe connection between an R&S SGU and an R&S SGS, which has a "Controller > Revision" < 5, first you have to set the correct PCIe interface mode manually. If your R&S SGS has a "Controller > Revision" 5 or higher, these settings are done automatically.



You can check the "Controller > Revision" of your instrument in the "SGMA-GUI > Instrument Name > Hardware Config" dialog.

### To set a PCIe direct connection between an R&S SGS and an R&S SGU manually

1. Connect the R&S SGS and the R&S SGU directly using a PCIe cable. Refer to [Chapter 10.3.4, "Connecting the Controller and the Instrument"](#), on page 176 for cable requirements and setup information.
2. Switch on the R&S SGS and the R&S SGU.
3. Select "SGMA-GUI main panel > Instrument Name > Setup > Maintenance".
4. Select "Operation > PCIe Interface Mode".
5. Select "PCIe Interface Mode > Root Complex".
6. Restart your instrument for the changes to take place.

The PCIe connection between the R&S SGS and the R&S SGU is established and the instruments can be used.

## 10 Network and Remote Control Operation

As an alternative to operating the R&S SGS interactively via the R&S SGMA-GUI, one can also control the R&S SGS using programmed commands from a remote PC.



The description in this section requires basic knowledge of the remote control operation. Definitions specified in the SCPI standard are not provided.

Nevertheless, you can find some basic information to the SCPI syntax, command lists, and general programming recommendations in [Chapter A, "Remote Control Basics"](#), on page 291. In addition, this chapter provides information on the status reporting system of the instrument.

### 10.1 Remote Control Interfaces and Protocols

The instrument supports several interfaces for remote control. The following table gives an overview.

**Table 10-1: Remote control interfaces and protocols**

Interface	Protocols, VISA <sup>*)</sup> address string and Library	Remarks
Local Area Network (LAN)	<ul style="list-style-type: none"> <li><b>HiSLIP</b> High-Speed LAN Instrument Protocol (IVI-6.1) TCPIP::host address::hislip0[::INSTR]</li> <li><b>VXI-11</b> TCPIP::host address::inst0[::INSTR] Library: VISA</li> <li><b>socket communication</b> (Raw Ethernet, simple Telnet) TCPIP::host address[::LAN device name]::&lt;port&gt;::SOCKET Library: VISA or socket controller</li> </ul>	<p>A LAN connector is located on the rear panel of the instrument.</p> <p>The interface is based on TCP/IP and supports various protocols.</p> <p>For details, see <a href="#">Chapter 10.1.2, "LAN Interface"</a>, on page 165</p>
USB	<p><b>USBTMC</b></p> <p>USB::&lt;vendor ID&gt;::&lt;product ID&gt;::&lt;serial number&gt;[::INSTR]</p> <p>Library: VISA</p>	<p>A USB connector is located on the rear panel of the instrument.</p> <p>For details, see <a href="#">Chapter 10.1.3, "USB Interface"</a>, on page 168</p>
PCIe	<p><b>Proprietary</b></p> <p>PCIe::&lt;vendor ID&gt;::&lt;product ID&gt;::&lt;serial number&gt;[::INSTR]</p> <p>Library: pcie controller</p>	<p>A PCIe connector is located on the rear panel of the instrument.</p> <p>For details, see <a href="#">Chapter 10.1.4, "PCI Express Interface"</a>, on page 169</p>
GPIB (IEC/IEEE Bus Interface)	<p>–</p> <ul style="list-style-type: none"> <li>GPIB::&lt;address&gt;[::INSTR] (no secondary address) VISA</li> </ul>	<p>The instrument is not equipped with GPIB bus interfaces. Use a GPIB-to-LAN or GPIB-to-USB adapter instead.</p> <p>For details, see <a href="#">Chapter 10.1.5, "GPIB Interface (IEC/IEEE Bus Interface)"</a>, on page 170</p>

<sup>\*)</sup> VISA is a standardized software interface library providing input and output functions to communicate with instruments. A VISA installation on the controller is a prerequisite

for remote control over LAN (when using VXI-11 or HiSLIP protocol) or USB. However, no VISA installation is necessary for remote control while using socket communication. For more information about VISA, refer to the user documentation.



Rohde & Schwarz provides the standardized I/O software library R&S VISA for communication via TCP/IP (LAN: HiSLIP, VXI-11 and raw socket) or USB (USBTMC) interfaces.

R&S VISA is available for download at the Rohde & Schwarz website <http://www.rohde-schwarz.com/rsvisa>.

### SCPI (Standard Commands for Programmable Instruments)

SCPI commands are used for remote control. Commands that are not taken from the SCPI standard follow the SCPI syntax rules. The instrument supports the SCPI version 1999. The SCPI standard is based on standard IEEE 488.2 and aims at the standardization of device-specific commands, error handling and the status registers. The tutorial "Automatic Measurement Control - A tutorial on SCPI and IEEE 488.2" from John M. Pieper (R&S order number 0002.3536.00) offers detailed information on concepts and definitions of SCPI.

## 10.1.1 Remote Control Programs and Libraries

The [Figure 10-1](#) provides a schematic illustration of the remote control capabilities of the instrument.

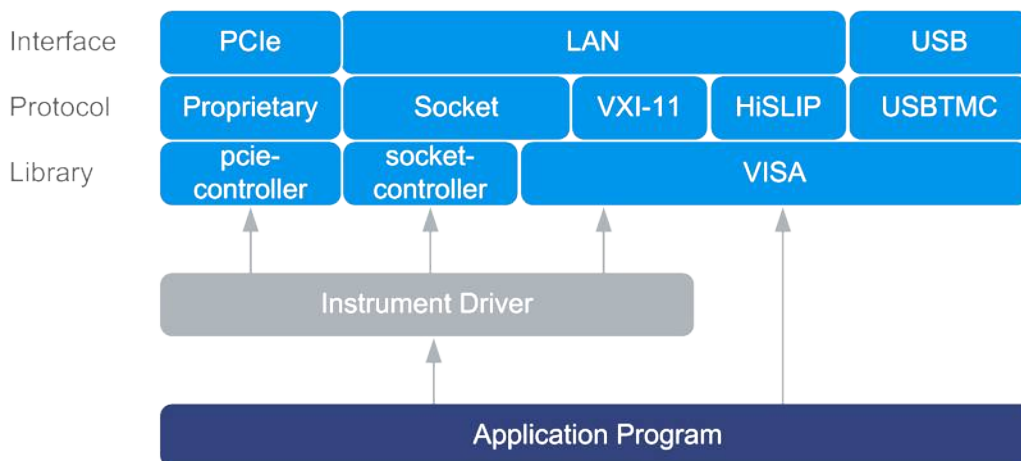

**Figure 10-1: Remote control interfaces, protocols and libraries**

The following examples give an overview of the dependencies between the available libraries, the possible interfaces and protocols, and whether an instrument driver is provided. The involved parts are **highlighted**.

- Remote control program using VISA

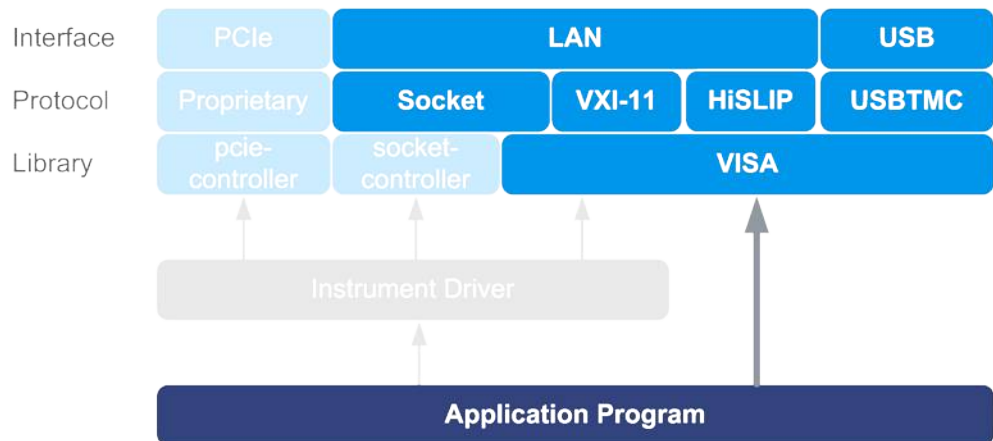

Figure 10-2: Remote control program using VISA

Protocol	Remote control program
Socket	<pre>viOpen (... , "TCPIP:rssgs100a100010::5025::SOCKET", ...) viPrintf (... , "SOUR:FREQ 2GHz\n")</pre>
VXI-11	<pre>viOpen (... , "TCPIP:rssgs100a100010::inst0::INSTR", ...) viPrintf (... , "SOUR:FREQ 2GHz\n")</pre>
HiSLIP	<pre>viOpen (... , "TCPIP:rssgs100a100010::hislip0::INSTR", ...) viPrintf (... , "SOUR:FREQ 2GHz\n")</pre>
USBTMC	<pre>viOpen (... , "USB::0x0aad::0x0088::1000010::INSTR", ...) viPrintf (... , "SOUR:FREQ 2GHz\n")</pre>

- Remote control program using instrument driver (VISA available)

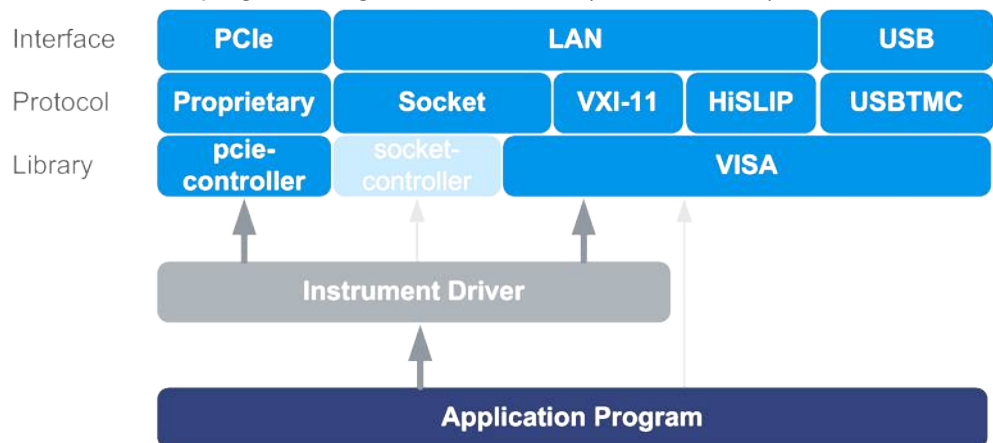

Figure 10-3: Remote control program using instrument driver (VISA available)

Protocol	Remote control program
Socket	<code>rssgs_init ("TCPIP:rssgs100a100010::5025::SOCKET", ...)</code> <code>rssgs_SetFrequency (... , 2e9)</code>
VXI-11	<code>rssgs_init ("TCPIP:rssgs100a100010::inst0::INSTR", ...)</code> <code>rssgs_SetFrequency (... , 2e9)</code>
HiSLIP	<code>rssgs_init ("TCPIP:rssgs100a100010::hislip0::INSTR", ...)</code> <code>rssgs_SetFrequency (... , 2e9)</code>
USBTMC	<code>rssgs_init ("USB::0x0aad::0x0088::1000010::INSTR", ...)</code> <code>rssgs_SetFrequency (... , 2e9)</code>
PCIe	<code>rssgs_init ("PCIe::0x162f::0x132e::1000010::INSTR", ...)</code> <code>rssgs_SetFrequency (... , 2e9)</code>

- Remote control program using instrument driver (VISA not available)

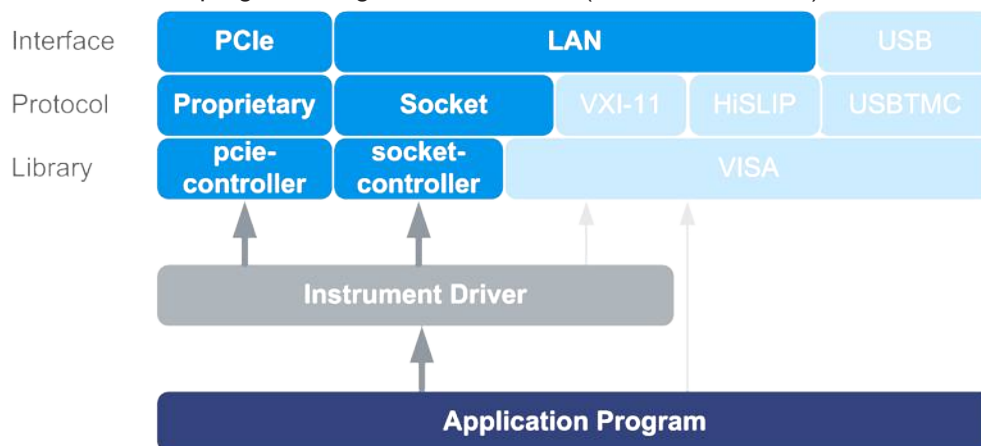

Figure 10-4: Remote control program using instrument driver (VISA not available)

Protocol	Remote control program
Socket	<code>rssgs_init ("TCPIP:rssgs100a100010::5025::SOCKET", ...)</code> <code>rssgs_SetFrequency (... , 2e9)</code>
PCIe	<code>rssgs_init ("PCIe::0x162f::0x132e::1000010::INSTR", ...)</code> <code>rssgs_SetFrequency (... , 2e9)</code>

### 10.1.2 LAN Interface

To be integrated in a LAN, the instrument is equipped with a LAN interface, consisting of a connector, a network interface card and protocols.

For remote control via a network, the PC and the instrument must be connected via the LAN interface to a common network with TCP/IP network protocol. They are connected using a RJ45 cable (shielded or unshielded twisted-pair category 5). The TCP/IP network protocol and the associated network services are preconfigured on the instru-

ment. Software for instrument control and (for specified protocols only) the VISA program library must be installed on the controller.



### Identifying instruments in a network

If several instruments are connected to the network, each instrument has its own IP address and associated resource string. The controller identifies these instruments by the resource string.

#### 10.1.2.1 VISA Resource Strings

The VISA resource string is required to establish a communication session between the controller and the instrument in a LAN. The resource string is a unique identifier, composed of the specific IP address of the instrument and some network and VISA-specific keywords.

```
TCPIP::host address[::LAN device name][::INSTR]
```

- **TCPIP** designates the network protocol used
- **host address** is the IP address or host name of the device  
See also [Chapter 6.4.3, "Finding Out the Default Hostname of the Instrument"](#), on page 71.
- **[::LAN device name]** defines the protocol and the instance number of a subinstrument:
- **[::INSTR]** indicates the instrument resource class (optional)

The **IP address** (host address/computer name) is used by the programs to identify and control the instrument. It is automatically assigned by the DHCP server the first time the device is registered on the network. Alternatively, you can also assign its **LAN device name**.

You can find the IP address in the "SGMA-GUI > Instrument Name > Setup > Remote" dialog, and also adjust it manually, if necessary.

See below the characteristics of the VISA resource strings for the corresponding interface protocols. The highlighted characters are crucial.

#### HiSLIP

```
TCPIP::host address::hislip0[::INSTR]
```

- **hislip0** HiSLIP device name, designates that the interface protocol HiSLIP is used (mandatory).

**hislip0** is composed of `[::HiSLIP device name[,HiSLIP port]]` and must be assigned.

For details of the HiSLIP protocol, refer to [Chapter 10.1.2.2, "HiSLIP Protocol"](#), on page 167.

#### VXI-11

```
TCPIP::host address[::inst0][::INSTR]
```

- **[::inst0]** LAN device name, indicates that the VXI-11 protocol is used (optional).

**inst0** currently selects the VXI-11 protocol by default and can be omitted.

For details of the VXI-11 protocol, refer to [Chapter 10.1.2.3, "VXI-11 Protocol"](#), on page 168

### Socket communication

TCPIP::**host address**::**port**::SOCKET

- **port** determines the used port number
- **SOCKET** indicates the raw network socket resource class

Socket communication requires the specification of the port (commonly referred to as port number) and of "SOCKET" to complete the VISA resource string with the associated protocol used.

The registered port for socket communication is port 5025.

See also [Chapter 10.1.2.4, "Socket Communication"](#), on page 168.

### Example:

- Instrument has the IP address *10.113.11.91*; the valid resource string using VXI-11 protocol is:

```
TCPIP::10.113.11.91::INSTR
```

- The DNS host name is *rssgs100a100021*; the valid resource string is:

```
TCPIP::rssgs100a100021::hislip0 (HiSLIP)
```

```
TCPIP::rssgs100a100021::inst0 (VXI-11)
```

- A raw socket connection can be established using:

```
TCPIP::10.113.11.91::5025::SOCKET
```

## 10.1.2.2 HiSLIP Protocol

The HiSLIP (**H**igh **S**peed **L**AN **I**nstrument **P**rotocol) is the successor protocol for VXI-11 for TCP-based instruments specified by the IVI foundation. The protocol uses two TCP sockets for a single connection - one for fast data transfer, the other for non-sequential control commands (e.g. `Device Clear` or `SRQ`).

HiSLIP has the following characteristics:

- High performance as with raw socket network connections
- Compatible IEEE 488.2 support for Message Exchange Protocol, Device Clear, Serial Poll, Remote/Local, Trigger, and Service Request
- Uses a single IANA registered port (4880), which simplifies the configuration of firewalls
- Supports simultaneous access of multiple users by providing versatile locking mechanisms
- Usable for IPv6 or IPv4 networks



Using VXI-11, each operation is blocked until a VXI-11 device handshake returns. However, using HiSLIP, data is sent to the device using the "fire and forget" method with immediate return. Thus, a successful return of a VISA operation such as `viWrite()` does not guarantee that the instrument has finished or started the requested command, but is delivered to the TCP/IP buffers.

For more information see also the application note:

[1MA208: Fast Remote Instrument Control with HiSLIP](#)

### 10.1.2.3 VXI-11 Protocol

The VXI-11 standard is based on the ONC RPC (Open Network Computing Remote Procedure Call) protocol which in turn relies on TCP/IP as the network/transport layer. The TCP/IP network protocol and the associated network services are preconfigured. TCP/IP ensures connection-oriented communication, where the order of the exchanged messages is adhered to and interrupted links are identified. With this protocol, messages cannot be lost.

### 10.1.2.4 Socket Communication

An alternative way for remote control of the software is to establish a simple network communication using sockets. The socket communication, also referred to as "Raw Ethernet communication", does not require a VISA installation on the remote controller side.

The simplest way to establish socket communication is to use the built-in telnet program. The telnet program is part of every operating system and supports communication with the software on a command-by-command basis.

Socket connections are established on a specially defined port. The socket address is a combination of the IP address or the host name of the instrument and the number of the port configured for remote-control. All instruments use port number 5025 for this purpose. The port is configured for communication on a command-to-command basis and for remote control from a program running on a connected PC.

## 10.1.3 USB Interface

For remote control via USB connection, the PC and the instrument must be connected via the USB interface. A USB connection requires the VISA library to be installed. VISA detects and configures the R&S instrument automatically when the USB connection is established. You do not have to install a separate driver.

### USB resource string

The syntax of the used USB resource string is:

`USB::<vendor ID>::<product ID>::<serial number>[: : INSTR]`, where:

- **USB** denotes the used interface

- **<vendor ID>** is the manufacturer ID for Rohde&Schwarz
- **<product ID>** is the product identification of the R&S instrument
- **<serial number>** is the individual serial number on the rear of the instrument
- **[::INSTR]** indicates the instrument resource class (optional)

You can retrieve the USB resource string from the "SGMA-GUI > Instrument Name > Setup > Remote" dialog.

**Example:**

```
USB::0x0AAD::0x0088::100021::INSTR
```

0x0AAD is the vendor ID for Rohde&Schwarz

0x0088 is the product ID for the R&S SGS

100021 is the serial number of the particular instrument

### 10.1.4 PCI Express Interface

A PCI Express (PCIe) connector is provided on the rear panel of the instrument.

Refer to [Chapter 10.3, "Advanced Remote Control Using PCIe"](#), on page 172 for a description of how to set up a remote control connection via PCIe and the permitted cables.

Via PCI Express some commands can be sent to the instrument with optimized speed (memory-mapped remote control), e.g. frequency or level settings. This allows minimum setup time.

**PCIe resource string**

The syntax of the used PCIe resource string is:

```
PCIe::<vendor ID>::<product ID>::<serial number>[::INSTR], where:
```

- **PCIe** denotes the used interface
- **<vendor ID>** is the manufacturer ID for Rohde&Schwarz
- **<product ID>** is the product identification of the R&S instrument
- **<serial number>** is the individual serial number on the rear of the instrument
- **[::INSTR]** indicates the instrument resource class (optional)

You can retrieve the PCIe resource string from the "SGMA-GUI > Instrument Name > Setup > Remote" dialog.

**Example:**

```
PCIe::0x162f::0x132e::100021::INSTR
```

0x162f is the vendor ID for Rohde&Schwarz

0x132e is the product ID for the R&S SGS

100021 is the serial number of the particular instrument

### 10.1.5 GPIB Interface (IEC/IEEE Bus Interface)

The R&S SGS is not equipped with an IEC/IEEE bus interface.

To be able to control the instrument via the GPIB bus:

1. Connect a GPIB-to-LAN or a GPIB-to-USB adapter to the instrument.
2. Use a GPIB bus cable to connect the instrument and the controller.
3. Provide the GPIB bus card, the card drivers and the program libraries for the programming language in the controller.
4. In the "SGMA-GUI > Setup > Instruments > instrument name > Remote Control", set the "GPIB Address".  
See "[GPIB Address](#)" on page 59.
5. If the controller is equipped with several GPIB bus cards, define the used "Board Number".

#### GPIB address

The controller must address the instrument with the GPIB bus channel. GPIB provides channel addresses from 0 to 30.

The GPIB resource string is `GPIB::<address>[: : INSTR]`, where:

- **GPIB** denotes the used interface
- **<address>** indicates the used channel
- **[: : INSTR]** indicates the instrument resource class (optional)

**Note:** If the VISA implementation supports the GPIB interface, you can optionally define the VISA instrument control resource (INSTR). It is used to define the basic operations and attributes for a device, such as reading, writing, or triggering.



Any connected IEC bus cable must be terminated by an instrument or controller.

---

## 10.2 Starting a Remote Control Session

The instrument and the controller have to be connected with a suitable cable and switched on.

A remote control program must open a connection to the instrument, before it can send commands to and receive device responses from the instrument.



### Instrument address

To operate the instrument via remote control, it must be addressed using the defined interface address.

See [Chapter 10.1.2, "LAN Interface"](#), on page 165, [Chapter 10.1.3, "USB Interface"](#), on page 168 or [Chapter 10.1.4, "PCI Express Interface"](#), on page 169 for details.



The VISA resource strings are indicated in the "SGMA-GUI main panel > Instrument name > Setup > Remote Channels" dialog.

## 10.2.1 How to Find the VISA Resource String

To find the VISA resource strings of your instrument:

- ▶ Select "SGMA-GUI main panel > Instrument name > Setup > Remote Channels".

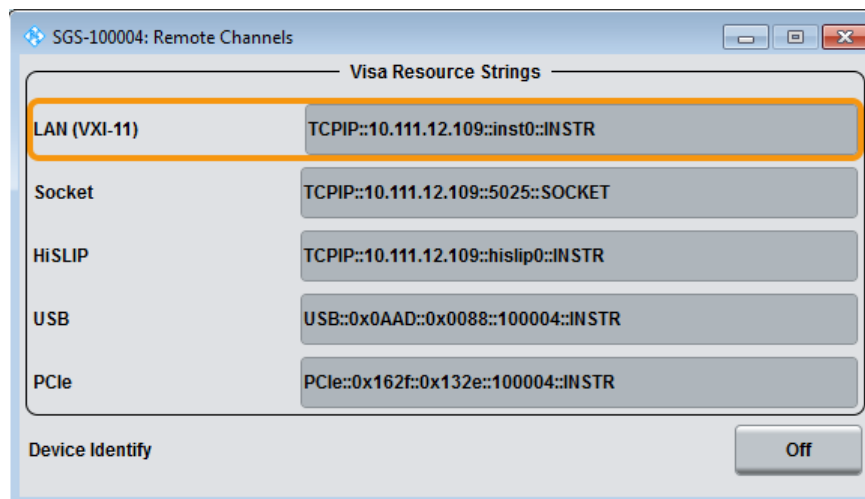

The "Remote Channel Settings" dialog shows all specified resource strings of the supported remote control interfaces.

## 10.2.2 Example: Remote Control over LAN Using Socket Communication

This section provides an example on how to establish a remote control connection over telnet protocol and a simple sockets-based program example that can be further developed (see also [Chapter B, "Telnet program examples"](#), on page 312).

Basic knowledge of programming and operation of the controller are assumed. A description of the interface commands can be obtained from the relevant manuals.



Refer to the getting started manual for an example on how to set up remote control connection over LAN using VXI-11 protocol.

### To set up a Telnet connection

To control the software, only a telnet program is required. The telnet program is part of every operating system.

1. To establish a Telnet connection with the R&S SGS, start the telnet program. Enter the socket address.

The socket address is a combination of the IP address or the host name of the R&S SGS and the number of the port configured for remote-control via telnet.

**Tip:** The R&S SGS uses the port number 5025 for remote connection via Telnet.

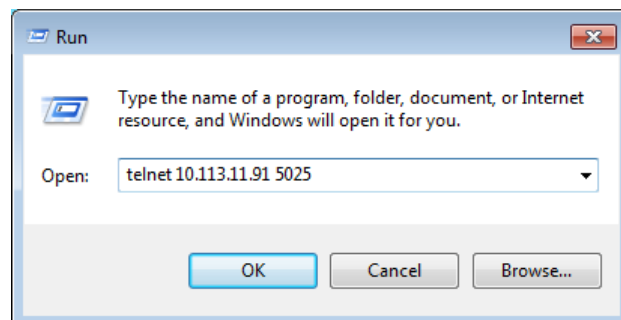

The connection to the instrument is set up and remote-control commands can be sent.

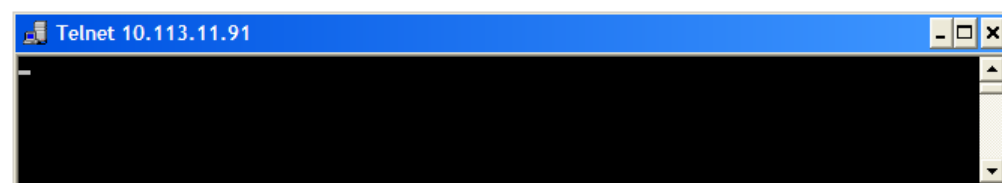

2. Even if the cursor is not visible on the screen, enter blind a remote-control command and confirm with Enter.

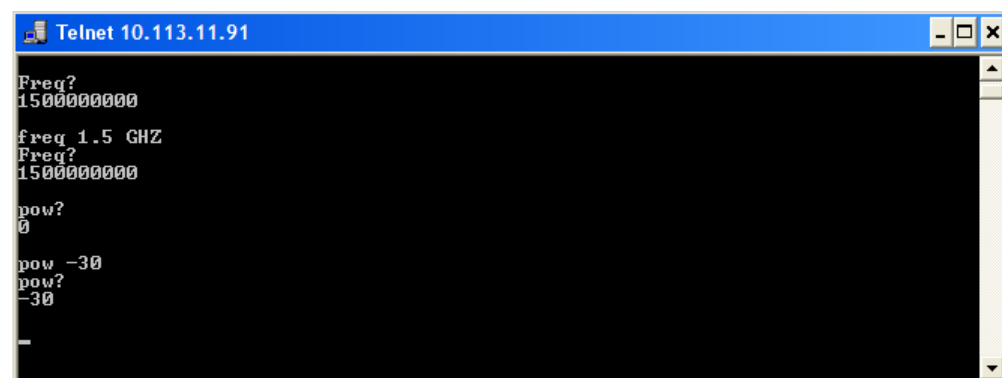

## 10.3 Advanced Remote Control Using PCIe

The PCIe bus is a high-speed serial bus, composed of point-to-point serial links. A pair of serial links, one transmitting and one receiving link, make up a lane.

### Fast settings

The PCIe interface can be utilized not only to transfer text messages e.g. SCPI commands but also to carry register based remote control messages. The latter mode is called fast settings mode. The specially for this purpose provided instrument's driver is mandatory for the instrument control with fast settings. This instrument driver contains special functions for fast setup.



To use the advantage of the fast settings, the following prerequisites must be fulfilled:

- Using the PCIe interface is mandatory (see also [Chapter 10.3.1, "Setting Up a Remote Control Connection via PCIe"](#), on page 173)
- The fast settings must be enabled with the function `rssgs_useFastSettings` (see also [Chapter 10.3.5, "Enabling Fast Settings"](#), on page 177).

The instrument driver automatically uses the fast settings method whenever possible - currently only for the parameters frequency, level, RF state, modulator state - and sends SCPI messages in all other cases.

Remote control programs written for PCIe will, without modifications, also run if one of the other control channels, LAN or USB is used.

## 10.3.1 Setting Up a Remote Control Connection via PCIe

To set up a remote control connection via PCIe, perform the following steps:

1. Download the drivers, see [10.3.2](#).
2. Configure the controller, see [10.3.3](#)
3. Connect the controller and the instrument, see [10.3.4](#)
4. Enable fast settings, see [10.3.5](#).

## 10.3.2 Download the Drivers

All required driver files are available for download on the product page at:

<http://www.rohde-schwarz.com/product/SGS100A.html> > "Downloads" > "Drivers"

Provided are the following files:

- LabWindows/CVI, Linux/OSX driver `rssgs (InstrumentDriver)` C source code files which provide a functional application programming interface (API) to R&S SGS instruments. Required if you want to control an instrument via PCIe.

- Low-Level SGS drivers

Archive file that contains the following:

- `KernelDriver`

C source code files from which you can build a Linux kernel mode driver for the R&S SGS PCIe remote control interface.

- `SgsDriverDemo`  
C source code module for a demo program using the instrument driver API.
- `SharedLibraries-Dlls`  
Shared libraries (Dlls) for remote control channels Socket and PCIe. To be used with the instrument driver.
- `VXIplug&play x64/x86 driver rssgs`

Download the required archive and extract the files on a remote PC.

### 10.3.3 Configuring the Controller

This section lists the steps necessary to configure a controller with Linux or Windows operating system.

#### 10.3.3.1 Building and Installing the Hardware Driver

The hardware driver defines the way to communicate with the instrument via PCIe interface.



For Windows operating systems, the hardware driver is installed automatically together with the installation of the R&S SGMA-GUI software.

See also section "Installation of R&S SGMA-GUI Software" in the getting started manual.

---

For Linux operating system, the source code of the driver is included in the `Low-Level SGS drivers` file.

To build and install this driver, root authority is required.

1. Copy folder `KernelDriver` to your `hdd`
2. Go to directory `host`.
3. On the command line, enter `make`.

The driver `sgshost.ko` is automatically built.

4. Enter `make install`.

Device nodes `sgsX` are created under the folder `/dev` (X from 0 to 31).  
The module `sgshost` is loaded.

5. Enter `lsmod` to verify the module.

### 10.3.3.2 Making Shared Libraries Accessible

Two library files per operating system are included in `SharedLibraries-Dlls` file:

- For Linux operating system  
`libsocketcontroller.so` and `libpciecontroller.so`
- For Windows operating system  
`SocketController.dll` and `PCIEController.dll`

These libraries act as the dynamic link libraries for programs using the socket or PCIe interface.

#### Linux operating system

- ▶ To make the libraries accessible, perform one of the following:
  - a) Append the environment variable `LD_LIBRARY_PATH` with the path of these two files e.g. by changing the `/etc/environment` file.
  - b) Move these two files to `/usr/lib` or `/lib` directory.

#### Windows operating system

- ▶ To make the libraries accessible, perform one of the following:
  - a) Copy these two files to the folder of your executable.
  - b) Copy these two files to the `WINDOWS\system32` folder.

### 10.3.3.3 Building a Program

The help file `rssgs_vxi.chm` shows all functions of the instrument which you can use in your own remote control program.

An example file is provided (`SgsDriverDemo.c`), too.

#### Building the example program (Linux)

1. Copy folders `InstrumentDriver` and `SgsDriverDemo` to your hard disk.
2. Go to folder `Build`
3. On the command line, enter `cmake ..`
4. Enter `make`  
Folder `Build` contains the executable `SgsDriverDemo`.

#### Building the example program (Windows)

1. Copy folders `InstrumentDriver` and `SgsDriverDemo` to your hard disk.
2. Open `SgsDriverDemo.vcproj` with Visual Studio.
3. Build the program.

### Running the example program

- On the command line, enter `./SgsDriverDemo RESOURCESTRING [cmd]`.

Where

- `RESOURCESTRING` is the (VISA) resource string of your instrument, e.g. `TCPIP::ipaddress::5025::SOCKET` or `PCIE::0x162f::0x132e::serialno::INSTR`.

Where `ipaddress` is the IP address or hostname of your instrument and `serialno` is its serial number.

- `cmd` is an optional command (see table).

The following table list the available commands.

Command	Description
?	Usage
q	Quit
f value	Set frequency
f?	Query frequency
l value	Set level
l?	Query level
r value	Set RF state (value = 0   1   ON   OFF)
r?	Query RF state

If you enter an additional optional command, `SgsDriverDemo` executes it and enters a loop waiting for further commands.

#### Example:

```
TCPIP::10.111.11.44::5025::SOCKET ?
```

Lists the available commands.

## 10.3.4 Connecting the Controller and the Instrument

A PCIe connector is provided on the rear panel of the instrument.

### NOTICE

#### Risk of device failure

The R&S SGS is equipped with a single lane PCIe interface that supports hot plugging. Do not connect an external PC to the PCIe connector of the instrument during operation if this external PC does not support hot-plugging!



### Permitted PCIe cables

PCIe extension cables must fulfill the following requirements:

- **Single lane connectors**
- **Max. cable length of 5 m.**

For example: OSS-PCIe-CBL-x1 cable from One Stop Systems or 74576-000x cable from Molex.

### Connecting an external PC that does not support hot-plugging

1. Switch off the external PC and the instrument.  
See also [Chapter 2.1.5, "Switching the Instrument On and Off"](#), on page 19.
2. Connect the instrument and the controller with the suitable cable.
3. Switch on the instrument.
4. Wait until the instrument has completed the booting (the "POWER" LED on the instrument's front panel is constantly on).
5. Switch on the external PC.

## 10.3.5 Enabling Fast Settings

- ▶ To enable the special PCI express feature fast settings, enable the function `rssgs_UseFastSettings` (`ViSession instrumentHandle`, `ViBoolean fastEnabled`, `ViBoolean asynchronousEnabled`) included in the instrument driver.

Settings for some parameters like level and frequency accelerate.

To disable the fast settings, call the function `rssgs_UseFastSettings` with argument `fastEnabled=false`.

## 10.4 Advanced Remote Control Using Fast Socket

### Fast settings

The socket interface can be utilized not only to transfer text messages e.g. SCPI commands but also to carry register based remote control messages. The latter mode is called fast settings mode. The fast socket communication is based on the Ethernet protocol which does not support routing. Therefore a controller PC can only control devices within its own network segment using the fast socket method.



To use the advantage of the fast settings, the following prerequisites must be fulfilled:

- On Windows operating systems, the fast socket driver must be installed.
- The application program must be run with root/administrator rights.
- The fast settings must be enabled with the function `rssgs_useFastSettings` (see also [Chapter 10.3.5, "Enabling Fast Settings"](#), on page 177).

The instrument driver uses the fast settings method whenever possible, currently for the parameters frequency, level, RF state, I/Q modulator state, IQ wideband state. In all other cases, SCPI messages are sent.

### 10.4.1 Setting Up a Remote Control Connection via Fast Socket

Download the required archive and extract the files on a remote PC, as described in [Chapter 10.3.2, "Download the Drivers"](#), on page 173.

#### Windows operating systems

To set up a remote control connection via fast socket for Windows operating systems, perform the following steps:

1. Connect the controller and the instrument, see [Chapter 2.3.2, "Connecting a Remote PC via LAN"](#), on page 24.
2. Install the protocol driver to the controller, see [Chapter 10.4.2, "Installing the Protocol Driver"](#), on page 179.
3. On the controller start the driver by using one of the following:
  - a) Start the Windows console user interface as an administrator.  
Execute the command `net start SGMANDISPROT`.
  - b) Use a program for opening the driver.  
See for example the example file `SgsDriverDemo.c`.
4. Start the application with administrator rights.
5. Enable fast settings, see [Chapter 10.4.3, "Enabling Fast Settings"](#), on page 179.

#### Linux operating systems

To set up a remote control connection via fast socket for Linux operating systems, perform the following steps:

1. Connect the controller and the instrument, see [Chapter 2.3.2, "Connecting a Remote PC via LAN"](#), on page 24.
2. Start the application as root.
3. Enable fast settings, see [Chapter 10.4.3, "Enabling Fast Settings"](#), on page 179.

## 10.4.2 Installing the Protocol Driver

The protocol driver defines the way to communicate with the instrument via the LAN fast socket interface.

For Linux operating system, no special driver is needed.

For Windows operating systems, the `SGMANDISPROT` driver is required. The protocol driver is installed automatically together with the installation of the R&S SGMA-GUI software. It is also provided in the `Low-Level SGS drivers` file.

To install the driver manually on a Windows operating system:

1. Open "Control Panel > Network and Sharing Center".
2. Select the network adapter on which you want to install the driver and click it. The "Local Area Connection Status" dialog opens.
3. Click "Properties" to open the "Local Area Connection Properties" dialog.
4. Click "Install" to open the "Select Network Feature Type" dialog.
5. Select "Protocol" and select "Add".
6. In the "Select Network Protocol" dialog, select "Have Disk".  
Navigate to the directory where the driver is saved and click "OK" to install the driver.

## 10.4.3 Enabling Fast Settings

- ▶ To enable the fast settings for the fast socket, call function `rssgs_UseFastSettings` (`ViSession instrumentHandle`, `ViBoolean fastEnabled`, `ViBoolean asynchronousEnabled`) included in the instrument driver.

Settings for some parameters like level and frequency accelerate.

To disable the fast settings, call the function `rssgs_UseFastSettings` with argument `fastEnabled=false`.

## 10.5 LXI Configuration

LAN eXtensions for Instrumentation (LXI) is an instrumentation platform for measuring instruments and test systems that is based on standard Ethernet technology. LXI is intended to be the LAN-based successor to GPIB, combining the advantages of Ethernet with the simplicity and familiarity of GPIB.

On the R&S SGS the LXI functionality is already installed and enabled. Thus, the instrument can be accessed via any web browser (like the Microsoft Internet Explorer) to perform the following tasks:

- Modifying network configurations
- Remote control of the instrument
- Performing SCPI remote diagnostics

### 10.5.1 Default State of the Network Settings

According to the LXI standard, an LCI must set the following parameters to a default state.

Parameter	Value
TCP/IP mode	DHCP + Auto IP Address
Dynamic DNS	Enabled
ICMP ping	Enabled
Password for LAN configuration	LxiWebIfc

The LAN reset also resets the following parameters for the R&S SGS:

Parameter	Value
Hostname	<Instrument-specific host name>
Description	Signal generator
Negotiation	Auto detect
VXI-11 discovery	Enabled

The LAN settings are configured using the instrument's [LXI Browser Settings](#).

### 10.5.2 LXI Browser Settings

To access the instrument via the web browser:

- ▶ Type in the instrument's host name or IP address in the address field of the browser on your PC, for example "http://10.111.0.125".  
**Note:** Do not add the missing zeros in the IP address, while opening the instrument home page.

The instrument home page (welcome page) opens.

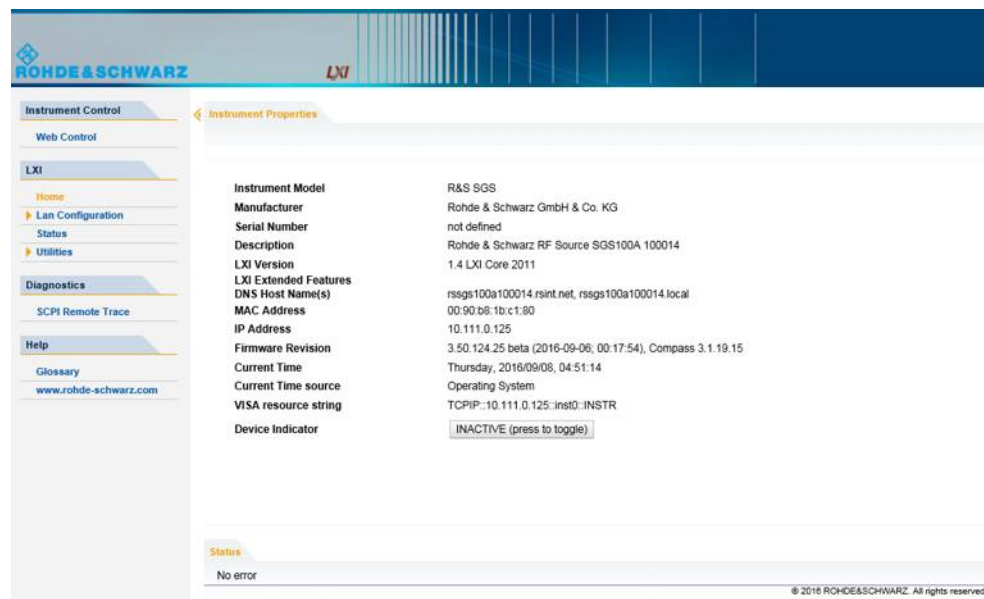

The navigation pane of the browser interface contains the following elements:

- "LXI"
  - "Home" opens the instrument home page.
 

The home page displays the device information required by the LXI standard, including the VISA resource string in read-only format.
  - "Device Indicator" activates or deactivates the LXI status indication.
 

When activated, the LXI LEDs flash in the browser dialog. A green LXI status symbol indicates that a LAN connection has been established; a red symbol indicates that no LAN cable is connected.
  - "Lan Configuration" allows you to configure LAN parameters and to initiate a ping, see [Chapter 10.5.3, "LAN Configuration"](#), on page 181.
  - "Status" displays information about the LXI status of the instrument.
  - "Utilities" provides access to the LXI event log functionality required by the LXI standard.
- "Instrument Control"
  - "Web Control" opens the R&S SGS Web-GUI for remote access to the instrument, see [Chapter 4.2, "Configuring a CW Signal with the R&S SGS100A Web-GUI"](#), on page 38.
- "Diagnostics"
  - "SCPI Remote Trace" records messages exchanged via the remote control interface, see [Chapter 10.5.3.4, "SCPI Remote Trace"](#), on page 184.
- "Help"
  - "Glossary" explains terms related to the LXI standard.
  - [www.rohde-schwarz.com](http://www.rohde-schwarz.com) opens the Rohde & Schwarz home page.

### 10.5.3 LAN Configuration

The "LAN Configuration" web page displays all mandatory LAN parameters and allows their modification.

It comprises the following navigation entries.

- [IP Configuration](#)..... 182
- [Advanced Config](#)..... 182
- [Ping Client](#)..... 183
- [SCPI Remote Trace](#)..... 184

### 10.5.3.1 IP Configuration

The "IP configuration" web page displays all mandatory LAN parameters and allows their modification.

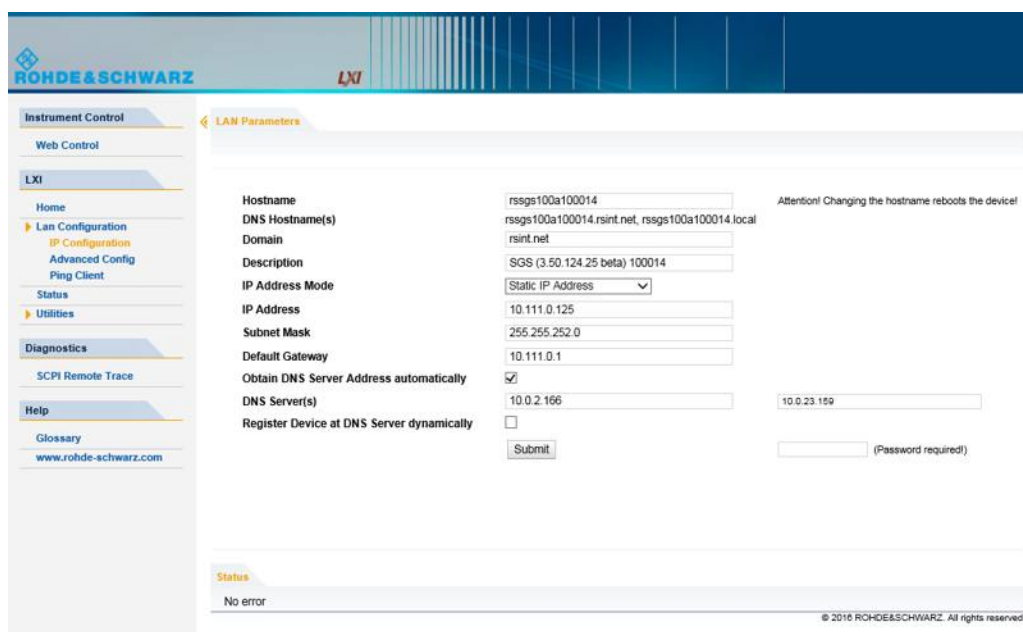

The "IP Address Mode" selects a configuration mode for the IP address of the instrument. With static configuration, the entered IP address, subnet mask, and default gateway are used. With dynamic configuration, DHCP or dynamic link local addressing (automatic IP) are used to obtain the instrument IP address.



#### Password protection

Changing the LAN configuration is password-protected and requires the security password. The default password is "instrument".

### 10.5.3.2 Advanced Config

The "Advanced Config" web page provides LAN settings that are not declared mandatory by the LXI standard.



The following advanced parameters are available:

- "mDNS and DNS-SD": The additional protocols "multicast DNS" and "DNS service discovery" are used for device communication in zero configuration networks, working without DNS and DHCP.
- "ICMP Ping": Must be enabled to use the ping utility. If you disable this setting, the instrument does not answer ping requests. The setting does not affect the LXI ping client. You can ping other hosts from the instrument, even if the setting is disabled.
- "VXI-11 Discovery": Must be enabled to detect the instrument in the LAN. If you disable this setting, the instrument cannot be detected by the VXI-11 discovery protocol mechanism. The setting does not affect other detection mechanisms. Setting up a VXI-11 connection via the IP address or the host name is independent of this setting.



### Password protection

Changing the LAN configuration is password-protected and requires the security password. The default password is "instrument".

#### 10.5.3.3 Ping Client

The "Ping Client" page provides the ping utility to verify the connection between the LXI-compliant instrument and another device.

The ping is initiated from the instrument. Using the `ICMP` echo request and echo reply packets, the function checks whether the communication with a device via LAN is working. Ping is useful for the diagnosis of IP network or router failures.

To initiate a ping at the instrument:

1. On the "Ping Client" page, enter the IP address of the host in the "Destination Address" field (for example 10.111.0.125).
2. Select "Submit".

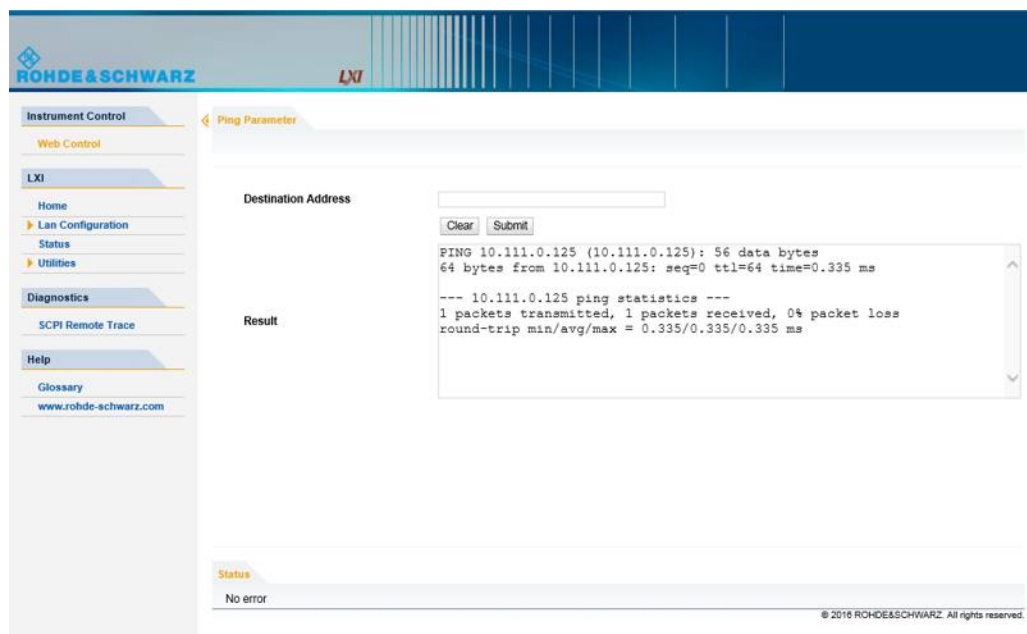

#### 10.5.3.4 SCPI Remote Trace

The remote trace functionality allows you to trace input and output strings at the remote control interface of the R&S SGS, see [Chapter 10.5.4, "How to Record SCPI Commands and Messages exchanged via the LXI Web Browser Interface"](#), on page 186.

A recorded trace (message log) can be evaluated directly in the dialog. Use the highlighting and navigation functions provided by the lower toolbar to locate error messages and messages containing arbitrary search strings. You can also export the message log to a \*.csv file and evaluate the file using a suitable program.

To trace and display messages, switch on "logging" and "live mode" in the toolbar.

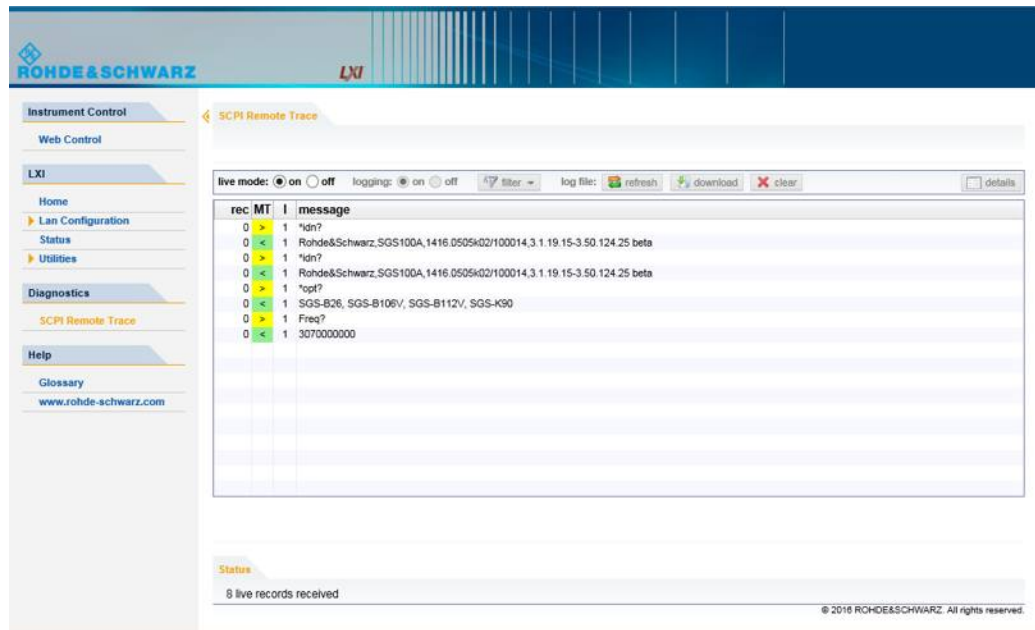

## Toolbars

The toolbar at the top of the dialog provides basic settings and functions.

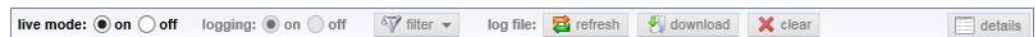

- "Live mode" / "logging": If logging is switched on, messages are traced. They are stored in an internal database and can be displayed upon request, using the refresh button (live mode off) or they can be displayed automatically (live mode on).
- "Filter": applies a filter to columns and/or rows when working (live mode off)
- "Refresh": reads the message log from the internal database and displays it
- "Download": stores the SCPI trace log to a \* .CSV file
- "Clear": deletes all message log entries in the database and at the screen
- "Details": displays details of the selected message, for example an SCPI command in hex format (also possible by double-clicking a message)

## Columns

The following columns are available if no column filter is applied:

- "Rec": record number of the message within the message log
- "MT": indicates the type of the message. Possible values and related message contents are:
  - > = incoming command
  - < = outgoing response to a query
  - E = error message, highlighted by red color
  - T = execution time, i.e. time required by the instrument to process the command internally

- I: number of the subinstrument
- "message": indicates the type of the message. Possible values and related message contents are:
  - > = incoming command
  - < = outgoing response to a query
  - E = error message, denoted in red
  - T = execution time, i.e. time required by the instrument to process the command internally

#### 10.5.4 How to Record SCPI Commands and Messages exchanged via the LXI Web Browser Interface

The remote trace functionality allows you to trace commands and messages exchanged via a remote control interface of the R&S SGS.

To activate the SCPI remote trace:

1. Start a web browser that supports html5 (W3C compliant).
2. Enter the IP address of the R&S SGS in the browser's address bar.  
The R&S SGS's welcome page is displayed.
3. In the navigation pane, select "Diagnostics > SCPI Remote Trace".
4. In the toolbar bar of the "SCPI Remote Trace" page, select "live mode > on" and "logging > on".  
"live mode > on" displays all commands and responses, and "logging > on" also traces messages.

If you now control the R&S SGS with SCPI commands, using an appropriate tool, the LXI function records the information sent and received.

Using the R&amp;S SGMA-GUI to Monitor the Remote Control Operation

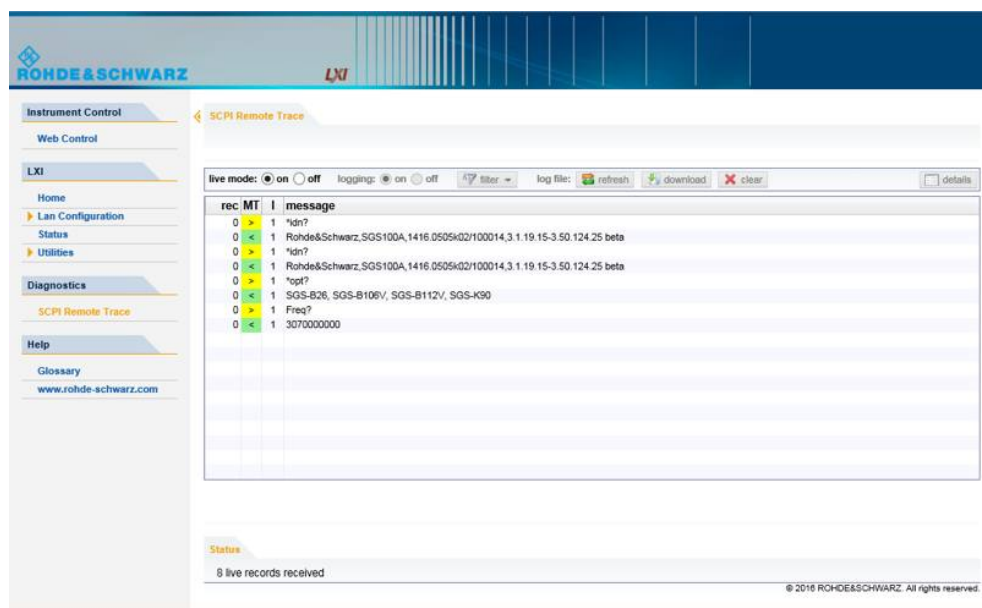

The function records all sent commands, received responses and messages, and stores them in an internal database. If "live mode" is disabled, you can display the recent traces upon request, using the "refresh" button. You can also store the log in a file.

## 10.6 Using the R&S SGMA-GUI to Monitor the Remote Control Operation

The R&S SGMA-GUI can be used to monitor the behavior of one or more instruments while they are remote controlled.

A typical configuration consists of one monitor, controllers and instruments. The monitor is the remote PC on which the R&S SGMA-GUI is installed and the controller is the remote PC on which the application program runs.

Simultaneous control of an instrument from a controller and a monitor may lead to collisions whenever both the controller and the monitor utilize the same remote channel. These collisions are indicated by an error message in the "Info" line, e.g. "Query interrupted" or "Resource locked". Simultaneous monitoring and control over the same remote channel is only possible, if the used protocols support `viLock()` / `viUnlock()` and the remote program use these functions.

The [Table 10-2](#) shows whether a collision-free communication over a particular combination of remote channels is possible or not and if there are any restrictions.

Table 10-2: Cross-reference between used remote channels and collision-free communication

Monitor/ Controller	LAN (VXI-11)	LAN (HiSLIP)	USB	LAN (Socket)	PCle
LAN (VXI-11)	OK*	OK	OK	OK	OK
LAN (HiSLIP)	OK	OK	OK	OK	OK
USB	OK	OK	viLock/viUnlock	OK	OK
LAN (Socket)	OK	OK	OK	X	OK
PCle	OK	OK	OK	OK	X

Where:

- **OK:** communication possible, no collisions  
\*) the R&S SGMA-GUI always uses the LAN device name **instr1**, see also [Chapter 10.1.2.3, "VXI-11 Protocol"](#), on page 168.
- **X:** communication is not possible without collisions
- **viLock/viUnlock:** communication is only possible, if the remote control commands are enclosed in a `viLock () - viUnlock ()` pair.



The R&S SGMA-GUI uses the `viLock () / viUnlock ()` functions.

The figure below shows an example of configuration where the monitor and the controller are two different computers, connected to the same instrument over two different hardware interfaces.

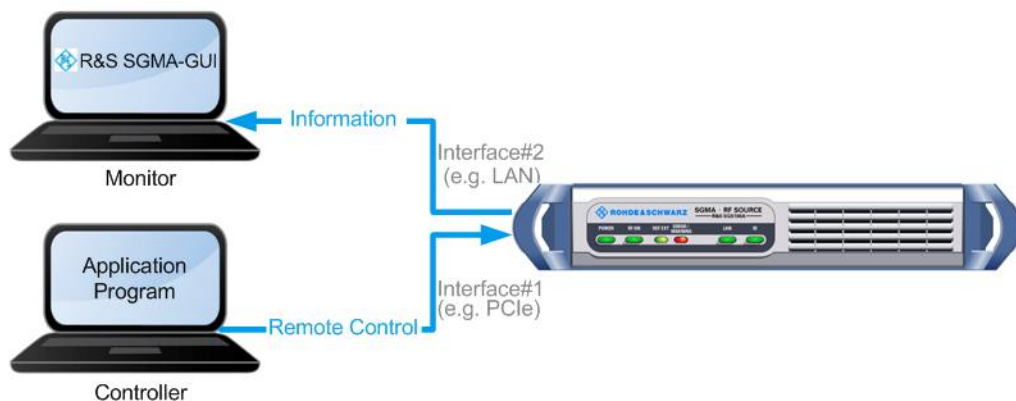

Figure 10-5: Example of a setup for remote control monitoring

### Connecting and configuring the monitoring PCs



In the "Setup > Security > Security Settings" dialog, check the state of the LAN and USB interfaces and enable them if necessary.

1. Connect the monitoring PC to the instrument.  
**Note:** Choose the hardware interface considering the limitations described in [Table 10-2](#).
2. Configure the instrument in the R&S SGMA-GUI, see [Chapter 6.4.2, "Handling Instruments in the R&S SGMA-GUI"](#), on page 68.
3. In the "SGMA-GUI > Setup > Instruments > Edit Instruments" dialog, disable "Exclusive Access".  
**Note:** The two functions "Exclusive Access" and monitoring are mutually exclusive.
4. Send remote control commands from the controller to the instrument.
5. Open the corresponding dialogs in the R&S SGMA-GUI. Observe the status of the parameters.

# 11 Remote Control Commands

In the following, all remote-control commands will be presented in detail with their parameters and the ranges of numerical values.

For an introduction to remote control and the status registers, refer to [Chapter A, "Remote Control Basics"](#), on page 291.

## Conventions used in SCPI Command Descriptions

Note the following conventions used in the remote command descriptions:

- **Command usage**  
If not specified otherwise, commands can be used both for setting and for querying parameters.  
If a command can be used for setting or querying only, or if it initiates an event, the usage is stated explicitly.
- **Parameter usage**  
If not specified otherwise, a parameter can be used to set a value and it is the result of a query.  
Parameters required only for setting are indicated as **Setting parameters**.  
Parameters required only to refine a query are indicated as **Query parameters**.  
Parameters that are only returned as the result of a query are indicated as **Return values**.
- **Conformity**  
Commands that are taken from the SCPI standard are indicated as **SCPI confirmed**. All commands used by the R&S SGS follow the SCPI syntax rules.
- **Asynchronous commands**  
A command which does not automatically finish executing before the next command starts executing (overlapping command) is indicated as an **Asynchronous command**.
- **Reset values (\*RST)**  
Default parameter values that are used directly after resetting the instrument (\*RST command) are indicated as **\*RST** values, if available.
- **Factory preset values**  
Default parameter values that are reset only by factory preset.
- **Default unit**  
The default unit is used for numeric values if no other unit is provided with the parameter.
- **Manual operation**  
If the result of a remote command can also be achieved in manual operation, a link to the description is inserted.

## 11.1 Programming Examples

This chapter provides simple programming examples for the R&S SGS. The purpose of the examples is to present **all** commands for a given task. In real applications, one would rather reduce the examples to an appropriate subset of commands.

The programming examples have been tested with a software tool which provides an environment for the development and execution of remote tests. To keep the examples as simple as possible, only the "clean" SCPI syntax elements are reported. Non-executable command lines (e.g. comments) start with two // characters.

At the beginning of most remote control program, an instrument (p)reset is recommended to set the R&S SGS to a defined state. The commands `*RST` and `SYSTem:PRESet` are equivalent for this purpose. `*CLS` also resets the status registers and clears the output buffer.

It is also recommended that you lock the instrument for remote control from the selected controller prior to further configuration. Use the `LOCK` command for this purpose.

We assume that the R&S SGS is fully equipped with all available options.

### 11.1.1 Performing General Task for Instrument Setup

In the following example we assume that a remote PC is connected to the instrument, the remote PC and the instrument are switched on and a connection between them is established.

```
// *****
// Reset instrument first
// *****

*RST; *CLS
// :SYSTem:PRESet
// :REStart
// :SYSTem:FPReset

// *****
// Lock the instrument to the controller
// *****

:LOCK? 72349234
// Lock instrument to avoid interference by other controllers
// Use an arbitrary number
// Response: 1
// Request granted, i.e. the instrument is locked
// Abort program if request is refused

// *****
// Launch selftest, diagnostic and internal adjustments and retrieve results
// *****
```

```

:TEST:ALL:START?
:TEST:ALL:RESult?
// Response: RUN
// Call :TEST:ALL:RESult? repeatedly until finished (0 or 1 is returned)

:DIAGNostic:POINt:CATalog?
// Response: D_TEMP_RFB,D_TEMP_CPU,D_TEMP_DBL,...
:DIAGNostic:MEASure:POINt? 'D_TEMP_RFB'

// Calibration functions may take several minutes
// Set timeout values of controller accordingly

:CALibration:ALL:MEASure?
// starts the adjustment of all functions for the entire instrument
// Response: 0 / 1
// i.e. adjustment has been performed successfully / adjustment failed
:CALibration:FREquency:MEASure?
// starts the adjustment of frequency and level
:CALibration:LEVel:MEASure?
// starts adjustments for maximum level accuracy

// Options R&S SGS-B106V or R&S SGS-B112V required for modulator functions
:CALibration:IQModulator:FULL?
:CALibration:IQModulator:LOCal

// *****
// Query the entries in the error queue
// *****

:SYSTem:SERRor?
// Query static errors
// :SYSTem:ERRor:CODE:COUNT?
// :SYSTem:ERRor:CODE:NEXT?
// :SYSTem:ERRor:NEXT?
// :STATus:QUEue:NEXT?
// :SYSTem:ERRor:CODE:ALL?
:SYSTem:ERRor:ALL?
// Query error queue

// *****
// Query system information
// *****

SYSTem:VERSion?

// *****
// Activate eco mode
// *****

```

```

:SYSTem:EMODe EM1

// *****
// Query the installed common assemblies and HW options
// *****

:SYSTem:SOFTware:OPTion1:NAME?
:SYSTem:SOFTware:OPTion1:DESignation?
:SYSTem:SOFTware:OPTion1:LICenses?
:SYSTem:SOFTware:OPTion1:EXPIration?

:SYSTem:HARDware:ASSEMBly1:NAME?
:SYSTem:HARDware:ASSEMBly1:PNUMber?
:SYSTem:HARDware:ASSEMBly1:SNUMber?
:SYSTem:HARDware:ASSEMBly1:REVIsion?

// *****
// Unlock the instrument
// *****

:UNL 72349234

```

### 11.1.2 Generating an I/Q Modulated Signal

In the following example we assume that a remote PC is connected to the instrument, the remote PC and the instrument are switched on and a connection between them is established. An external analog signal is provided at the I and Q connectors of the instrument.

```

// *****
// Reset instrument first
// *****

*RST; *CLS

// *****
// Lock the instrument to the controller
// *****

:LOCK? 72349234
// Lock instrument to avoid interference by other controllers
// Use an arbitrary number
// Response: 1
// Request granted, i.e. the instrument is locked
// Abort program if request is refused

// *****
// Select normal operation mode
// *****

```

```

:SOURce:OPMode NORMal

// *****
// Set RF frequency and level
// *****

:SOURce:FREQuency:CW 2 GHz
// :SOURce:PHASe 0
// :SOURce:PHASe:REFerence
:SOURce:POWer -10dBm
:SOURce:POWer:PEP?

// *****
// Enable internal reference frequency source
// *****

:SOURce:ROSCillator:SOURce INTernal

// *****
// Enable internal LO source
// *****

:SOURce:LOSCillator:SOURce INT

// *****
// Define and enable impairments
// Enable modulation
// *****

:SOURce:IQ:IMPairment:LEAKage:I -1
:SOURce:IQ:IMPairment:LEAKage:Q 1
:SOURce:IQ:IMPairment:IQRatio:MAGNitude 1
// Sets the gain imbalance to 1 %
:SOURce:IQ:IMPairment:IQRatio:MAGNitude?
// Response: 0.087 dB
:SOURce:IQ:IMPairment:QUADrature:ANGLE 2
:SOURce:IQ:WBState ON
:SOURce:IQ:CREStfactor 0.05

:SOURce:IQ:IMPairment:STATe ON
:SOURce:IQ:STATe ON

// *****
// Enable output of the generated signal at the RF connector
// *****

:OUTPut:STATe ON

// *****

```

```
// Unlock the instrument
// *****

:UNL 72349234
```

### 11.1.3 Adjusting Network and Remote Channel Settings

In the following example we assume that a remote PC is connected to the instrument, the remote PC and the instrument are switched on and a connection between them is established.

```
// *****
// Reset instrument first
// *****

*RST; *CLS

// *****
// Lock the instrument to the controller
// *****

:LOCK? 72349234
// Lock instrument to avoid interference by other controllers
// Use an arbitrary number
// Response: 1
// Request granted, i.e. the instrument is locked
// Abort program if request is refused

// *****
// Query the VISA resource strings
// *****

:SYSTem:COMMunicate:NETWork:RESource?
// Response: TCPIP::10.113.11.91::INSTR
:SYSTem:COMMunicate:SOCKet:RESource?
// Response: TCPIP:rssgs100a100021::5025::SOCKET
:SYSTem:COMMunicate:USB:RESource?
// Response: USB::0x0AAD::0x0088::100021::INSTR
:SYSTem:COMMunicate:PCIexpress:RESource?
// Response: PCIe::0x0AAD::4909::100021::INSTR

// *****
// Query network settings
// *****

:SYSTem:COMMunicate:NETWork:COMMon:HOSTname?
// Response: rssgs100a100021
:SYSTem:COMMunicate:NETWork:IPAddress:MODE?
// Response: AUTO
```

```

:SYSTem:COMMunicate:NETWork:IPAddress?
// Response: 10.113.11.91
:SYSTem:COMMunicate:NETWork:IPAddress:SUBNet:MASK?
//Response: 255.255.0.0
:SYSTem:COMMunicate:NETWork:IPAddress:GATeway?
//Response: 10.113.0.1

// *****
// Changing network settings
// *****

:SYSTem:PROTect1:STATe OFF,123456
// :SYSTem:COMMunicate:NETWork:COMMon:HOSTname "mySGS"
// :SYSTem:COMMunicate:NETWork:IPAddress:MODE STATic
// :SYSTem:COMMunicate:NETWork:IPAddress 9.8.7.6
:SYSTem:COMMunicate:NETWork:REStart

// *****
// Unlock the instrument
// *****

:UNL 72349234

```

#### 11.1.4 Advanced Task for Optimizing Performance

In the following example we assume that a remote PC is connected to the instrument, the remote PC and the instrument are switched on and a connection between them is established.

```

// *****
// Reset instrument first
// *****

*RST; *CLS
// :SYSTem:PRESet
// :REStart
// :SYSTem:FPReset

// *****
// Lock the instrument to the controller
// *****

:LOCK? 72349234
// Lock instrument to avoid interference by other controllers
// Use an arbitrary number
// Response: 1
// Request granted, i.e. the instrument is locked
// Abort program if request is refused

```

```

// *****
// Query and adjust the reference oscillator settings
// *****

:SOURce:ROSCillator:SOURce?
// Response: EXT
:SOURce:ROSCillator:EXTErnal:FREQuency?
// Response: 100MHZ
:SOURce:ROSCillator:EXTErnal:SBANdwidth?
//Response: WIDE
:SOURce:ROSCillator:SOURce INTernal
:SOURce:ROSCillator:OUTput:FREQuency 100MHZ
:SOURce:ROSCillator:INTernal:ADJust:STATe OFF
// uses the calibrated adjustment value of the internal ref. frequency
:SOURce:ROSCillator:INTernal:ADJust:VALue?
:CONNector:REFLo:OUTPut?
// Response: REF

// *****
// Optimizing the quality characteristics of the RF signal
// *****

:SOURce:POWer:LMODe LNO
// optimize the signal to noise ratio
:SOURce:POWer:SCHaracteristic AUTO
// ensure highest dynamic range and fastest setting time
:SOURce:POWer:LEVel:IMMediate:AMPLitude -30dBm
:SOURce:POWer:LIMit:AMPLitude 30dBm
:SOURce:POWer:ALC:SONCe
:OUTPut:STATe:PON UNCHanged

// *****
// Unlock the instrument
// *****

:UNL 72349234

```

### 11.1.5 Enabling and Configuring an Extension Mode

In the following example we assume that a remote PC is connected to the instrument, the remote PC and the instrument are switched on and a connection between them is established; the required application program is running on the remote PC. We assume that at least one R&S SGU is connected to the instrument, directly or over network/switch, i.e. there is a remote control connection between the instrument and the extension; we assume, that the required signal connections between the instrument and the extension are established, too.

```

// *****
// Reset instrument first

```

```

// *****

*RST; *CLS
// :SYSTem:PRESet
// :REStart
// :SYSTem:FPReset

// *****
// Lock the instrument to the controller
// *****

:LOCK? 72349234
// Lock instrument to avoid interference by other controllers
// Use an arbitrary number
// Response: 1
// Request granted, i.e. the instrument is locked
// Abort program if request is refused

// *****
// Confirm that there is no extension currently enabled for the instrument
// Scan the network for available extension instruments and
// query information on the available instruments:
// hostname/IP adress, serial number, used remote channel
// select and enable an extension
// *****
:EXTension:SElect?
// 0
// no extension is currently enabled

:EXTension:INSTRuments:SCAN:STATE 1
:EXTension:INSTRuments:SCAN:STATE?
// 1
// scan process is running
:EXTension:INSTRuments:SCAN:STATE?
// 0
// scan finished

:EXTension:INSTRuments:REMote:LAN:NAME?
// rsgu100a100002,rsgu100a101010
:EXTension:INSTRuments:REMote:CHANnel?
// LAN,LAN
:EXTension:INSTRuments:REMote:SERial?
// 100002,101010
// there are two available extensions

// select and enable the first extension (rsgu100a100002)
:EXTension:SElect 1
// determines the extension
// all further remote control commands are related to this extension
:EXTension:REMote:STATE?

```

```

// 1
:EXTension:BUSY:STATe?
// 0
// extension is connected and ready for operation

// *****
// Send remote commands to the extension to control it
// e.g. activate the RF optput of the extension and subsequently confirm this
// *****
:EXTension:SEND ":OUTP:STAT ON"
:EXTension:SEND? ":OUTP:STAT?"
// 1
// the RF ouptput of the extension is active

// *****
// Unlock the instrument
// *****

:UNL 72349234

```

## 11.2 Common Commands

Common commands are described in the IEEE 488.2 (IEC 625-2) standard. These commands have the same effect and are employed in the same way on different devices. The headers of these commands consist of "\*" followed by three letters. Many common commands are related to the Status Reporting System.

Available common commands:

*CLS.....	200
*ESE.....	200
*ESR?.....	200
*IDN?.....	200
*IST?.....	200
*OPC.....	201
*OPT?.....	201
*PRE.....	201
*PSC.....	201
*RCL.....	202
*RST.....	202
*SAV.....	202
*SRE.....	202
*STB?.....	202
*TRG.....	203
*TST?.....	203
*WAI.....	203

---

**\*CLS**

Clear status

Sets the status byte (STB), the standard event register (ESR) and the `EVENT` part of the `QUESTIONABLE` and the `OPERATION` registers to zero. The command does not alter the mask and transition parts of the registers. It clears the output buffer.

**Usage:**                   Setting only

---

**\*ESE <Value>**

Event status enable

Sets the event status enable register to the specified value. The query returns the contents of the event status enable register in decimal form.

**Parameters:****<Value>**                   Range:     0 to 255

---

**\*ESR?**

Event status read

Returns the contents of the event status register in decimal form and then sets the register to zero.

**Return values:****<Contents>**               Range:     0 to 255**Usage:**                   Query only

---

**\*IDN?**

Identification

Returns the instrument identification.

**Return values:****<ID>**                       "Rohde&Schwarz,<device type>,<part number>/<serial number>,<firmware version>"**Example:**               Rohde&Schwarz,SGS100A,  
1412.0000K02/000000,3.1.17.1-03.01.158**Usage:**                   Query only

---

**\*IST?**

Individual status query

Returns the contents of the IST flag in decimal form. The IST flag is the status bit which is sent during a parallel poll.

**Return values:**

&lt;ISTflag&gt; 0 | 1

**Usage:** Query only**\*OPC**

Operation complete

Sets bit 0 in the event status register when all preceding commands have been executed. This bit can be used to initiate a service request. The query writes a "1" into the output buffer when all preceding commands have been executed, which is useful for command synchronization.

**\*OPT?**

Option identification query

Queries the options included in the instrument. For a list of all available options and their description, refer to the data sheet.

**Return values:**

<Options> The query returns a list of options. The options are returned at fixed positions in a comma-separated string. A zero is returned for options that are not installed.

**Usage:** Query only**\*PRE <Value>**

Parallel poll register enable

Sets parallel poll enable register to the indicated value. The query returns the contents of the parallel poll enable register in decimal form.

**Parameters:**

&lt;Value&gt; Range: 0 to 255

**\*PSC <Action>**

Power on status clear

Determines whether the contents of the `ENABLE` registers are preserved or reset when the instrument is switched on. Thus a service request can be triggered when the instrument is switched on, if the status registers ESE and SRE are suitably configured. The query reads out the contents of the "power-on-status-clear" flag.

**Parameters:**

&lt;Action&gt; 0 | 1

**0**

The contents of the status registers are preserved.

**1**

Resets the status registers.

---

**\*RCL** <Number>

## Recall

Loads the instrument settings from an intermediate memory identified by the specified number. The instrument settings can be stored to this memory using the command **\*SAV** with the associated number.

It also activates the instrument settings which are stored in a file and loaded using the **MMEMory:LOAD** <number>, <file\_name.extension> command.

---

**\*RST**

## Reset

Sets the instrument to a defined default status. The default settings are indicated in the description of commands.

The command is equivalent to **SYSTEM:PRESet**.

**Usage:**                      Setting only

---

**\*SAV** <Number>

## Save

Stores the current instrument settings under the specified number in an intermediate memory. The settings can be recalled using the command **\*RCL** with the associated number.

To transfer the stored instrument settings in a file, use the command **:MMEMory:STORe:STATe**.

---

**\*SRE** <Contents>

## Service request enable

Sets the service request enable register to the indicated value. This command determines under which conditions a service request is triggered.

**Parameters:**

<Contents>                      Contents of the service request enable register in decimal form.  
Bit 6 (MSS mask bit) is always 0.

Range:                      0 to 255

---

**\*STB?**

## Status byte query

Reads the contents of the status byte in decimal form.

**Usage:** Query only

---

### \*TRG

Trigger

Triggers all actions waiting for a trigger event. In particular, \*TRG generates a manual trigger signal. This common command complements the commands of the TRIGger subsystem.

**Usage:** Event

---

### \*TST?

Self-test query

Initiates self-tests of the instrument and returns an error code.

**Return values:**

<ErrorCode>	<b>integer &gt; 0 (in decimal format)</b> An error occurred. (For details, see the Service Manual supplied with the instrument).
	<b>0</b> No errors occurred.

**Usage:** Query only

---

### \*WAI

Wait to continue

Prevents servicing of the subsequent commands until all preceding commands have been executed and all signals have settled (see also command synchronization and \*OPC).

**Usage:** Event

## 11.3 General Commands

:LOCK?.....	203
:UNLock.....	204

---

**:LOCK? <LockRequestId>**

Sends a lock request ID which uniquely identifies the controller to the instrument.

**Parameters:**

<LockRequestId>	Number
-----------------	--------

**0**

test query to prove whether the instrument is locked

**Controller ID**

request lock from the controller with the specified Controller ID

**Return values:**

&lt;Value&gt;

Number

**0**

request refused; the instrument is already locked to other &lt;Lock Request Id&gt;, i.e. to another controller

**1**

request granted

**Example:**

:LOCK? 12345

Response: 1

:UNL 12345

**Usage:**

Query only

**Manual operation:** See ["Exclusive Access"](#) on page 58**:UNLock <UnlockId>**

Unlocks an instrument locked to a controller with Controller ID = &lt;Unlock Id&gt;.

**Setting parameters:**

&lt;UnlockId&gt;

Number

Unlock ID which uniquely identifies the controller to the instrument. The value must match the Controller ID <Lock Request Id> set with the command [:LOCK?](#).**0**

Clear lock regardless of locking state

**Usage:**

Setting only

**Manual operation:** See ["Exclusive Access"](#) on page 58

## 11.4 Preset Commands

The preset commands are not bundled into one subsystem. Therefore, they are listed separately in this section. In addition, a specific preset command is provided for each digital standard and for the fader. These specific commands are described in the associated subsystems.

The following presetting actions are available:

- Activating the default state of all internal instrument functions ([\\*RST](#) on page 202). Functions that concern the integration of the instrument into a measurement setup are not changed, e.g. TCP/IP address or reference oscillator source settings.

- Activating the original state of delivery (factory reset, `:SYSTem:FPReset` on page 205). Only functions that are protected by a password remain unchanged as well as the passwords themselves.

---

**:SOURce<hw>:PRESet**
**:SYSTem:PRESet**

Triggers an instrument reset. It has the same effect as:

- The `*RST` command
- The "SGMA-GUI > Instrument Name > Preset" function

For an overview of the settings affected by the preset function, see [Chapter 7.9, "Preset"](#), on page 123.

**Example:**

```
SYST:PRES
```

All instrument settings (also the settings that are not currently active) are reset to their default values.

**Usage:**

Setting only

---

**:SYSTem:FPReset**

Triggers an instrument reset to the original state of delivery.

**Example:**

```
SYST:FPR
```

all instrument settings (also those that are not currently active) are reset to the factory values.

**Usage:**

Event

**Manual operation:** See ["Execute Factory Preset"](#) on page 143

## 11.5 CALibration Subsystem

<a href="#">:CALibration:ALL[:MEASure]?</a> .....	205
<a href="#">:CALibration:FREQUency[:MEASure]?</a> .....	206
<a href="#">:CALibration:IQModulator:FULL?</a> .....	206
<a href="#">:CALibration:IQModulator:LOCal?</a> .....	206
<a href="#">:CALibration:LEVel[:MEASure]?</a> .....	206
<a href="#">:CALibration:LEVel:TEMPerature?</a> .....	207
<a href="#">:CALibration:FREQUency:TEMPerature?</a> .....	207
<a href="#">:CALibration:IQModulator:TEMPerature?</a> .....	207
<a href="#">:CALibration:OEXTension</a> .....	207
<a href="#">:CALibration:ROSCillator:DATA:MODE</a> .....	207
<a href="#">:CALibration:ROSCillator[:DATA]</a> .....	208

---

**:CALibration:ALL[:MEASure]?**

Starts all internal adjustments for which no external measuring equipment is needed.

**Return values:**

<All> 0 | 1 | OFF | ON

**Example:**

See [Chapter 11.1.1, "Performing General Task for Instrument Setup"](#), on page 191.

**Usage:**

Query only

**Manual operation:**

See ["Adjust All"](#) on page 129

---

**:CALibration:FREQuency[:MEASure]?**

Performs all adjustments which affect the frequency.

**Return values:**

<Synthesis> 0 | 1 | OFF | ON

**Example:**

See [Chapter 11.1.1, "Performing General Task for Instrument Setup"](#), on page 191.

**Usage:**

Query only

**Manual operation:**

See ["Synthesis"](#) on page 129

---

**:CALibration:IQModulator:FULL?**

Starts the adjustment of the I/Q modulator for the entire frequency range. The I/Q modulator is adjusted with respect to carrier leakage, I/Q imbalance and quadrature.

**Return values:**

<Modulator> 0 | 1

**Example:**

See [Chapter 11.1.1, "Performing General Task for Instrument Setup"](#), on page 191.

**Usage:**

Query only

**Manual operation:**

See ["I/Q Modulator"](#) on page 130

---

**:CALibration:IQModulator:LOCal?**

Starts the adjustment of the I/Q modulator for the current frequency. The I/Q modulator is adjusted with respect to carrier leakage, I/Q imbalance and quadrature.

**Example:**

See [Chapter 11.1.1, "Performing General Task for Instrument Setup"](#), on page 191.

**Usage:**

Query only

**Manual operation:**

See ["Adjust I/Q Modulator at Current Frequency"](#) on page 129

---

**:CALibration:LEVel[:MEASure]?**

Starts all adjustments which affect the level.

**Return values:**

<Level> 0 | 1 | OFF | ON

**Example:**

See [Chapter 11.1.1, "Performing General Task for Instrument Setup"](#), on page 191.

**Usage:**

Query only

**Manual operation:** See "[Level](#)" on page 129

**:CALibration:LEVel:TEMPerature?****:CALibration:FREQuency:TEMPerature?****:CALibration:IQModulator:TEMPerature?**

Queries the delta temperature since the last performed adjustment.

**Return values:**

<Temperature> string

**Usage:**

Query only

**Manual operation:** See "[Delta Temperature](#)" on page 130

**:CALibration:OEXTension <OExtension>**

This SCPI command is used when the instrument is in extension mode.

Enables you to run an internal adjustment only on the extension instrument.

**Parameters:**

<OExtension> 0 | 1 | OFF | ON

\*RST: 0

**Example:**

:CAL:OEXT ON

activates the mode for calibrating only the extension instrument

:CAL:LEV:MEAS?

calibrates only the extension instrument

:CAL:OEXT OFF

deactivates the mode for calibrating only the extension instrument

**:CALibration:ROSCillator:DATA:MODE <Mode>**

Defines whether the factory provided or a custom defined calibration value is used to adjust the reference oscillator.

**Parameters:**

<Mode> FACTory | CUSTomer

\*RST: FACTory

**Example:**

:CALibration1:ROSCillator:DATA:MODE CUSTomer

:CALibration1:ROSCillator:DATA 35600

**Manual operation:** See "[Active Adjustment Data](#)" on page 146

**:CALibration:ROSCillator[:DATA] <Data>**

Sets the calibration value for the custom defined external adjustment.

**Parameters:**

<Data> integer  
 Range: 0 to INT\_MAX  
 \*RST: 0

**Example:** See [:CALibration:ROSCillator:DATA:MODE](#) on page 207

**Manual operation:** See ["Calibration Value"](#) on page 146

## 11.6 CONNector Subsystem

<a href="#">:CONNector:REFLo:OUTPut</a> .....	208
<a href="#">:CONNector:TRIGger:OMODE</a> .....	208

**:CONNector:REFLo:OUTPut <Output>**

Determines the signal provided at the output connector [REF/LO OUT] (rear of the instrument).

**Parameters:**

<Output> REF | LO | OFF  
 \*RST: REF

**Manual operation:** See ["REF/LO Output"](#) on page 84

**:CONNector:TRIGger:OMODE <Mode>**

Sets the operating mode of the trigger connector.

The parameters `PVOut` | `PETRigger` | `PEMSource` are available only with option R&S SGS-K22.

**Parameters:**

<Mode> SVALid | SNValid | PVOut | PETRigger | PEMSsource  
**SVALid|SNValid**  
 signal valid /not valid  
**PVOut**  
 pulse generator video out  
**PETRigger**  
 pulse generator external trigger  
**PEMSsource**  
 external pulse modulator source

**Manual operation:** See ["Trigger Connector Mode"](#) on page 116

## 11.7 DIAGnostic Subsystem

:DIAGnostic:POINt:CATalog?	209
:DIAGnostic[:MEASure]:POINt?	209

---

### :DIAGnostic:POINt:CATalog?

Queries the test points available in the instrument.

For description of the test points, see the service manual.

**Example:** See [Chapter 11.1.1, "Performing General Task for Instrument Setup"](#), on page 191.

**Usage:** Query only

---

### :DIAGnostic[:MEASure]:POINt? <Name>

Triggers voltage or temperature measurement at the specified test point and returns the measured value.

Use the command `:DIAGnostic:POINt:CATalog?` to retrieve a list of the available test points.

For description of the test points, see the service manual.

#### Query parameters:

<Name> string

#### Return values:

<Value> number  
Default unit: V or °C

**Example:** See [Chapter 11.1.1, "Performing General Task for Instrument Setup"](#), on page 191.

**Usage:** Query only

## 11.8 EXTension Subsystem

:EXTension:REMOte:STATe?	210
:EXTension:INSTruments:NAME?	210
:EXTension:INSTruments:SCAN[:STATe]	210
:EXTension:INSTruments:REMOte:CHANnel?	210
:EXTension:INSTruments:REMOte:LAN:NAME?	211
:EXTension:INSTruments:REMOte:SERial?	211
:EXTension:BUSY[:STATe]?	211
:EXTension:SELect	212
:TEST:EXTension:CONNection?	212
:TEST:EXTension:CONNection:RF?	212

---

**:EXTension:REMOte:STATe?**

Queries the state of the remote control connection to the extension.

**Return values:**

<State>            0 | 1 | OFF | ON  
                      **1|ON**  
                      Connected  
                      **0|OFF**  
                      Not connected

**Example:**            See [Chapter 11.1.5, "Enabling and Configuring an Extension Mode"](#), on page 197.

**Usage:**                Query only

**Manual operation:** See "[Available Instruments](#)" on page 126

---

**:EXTension:INSTruments:NAME?**

Queries the list of the symbolic names of the available extension devices.

**Usage:**                Query only

**Manual operation:** See "[Available Instruments](#)" on page 126

---

**:EXTension:INSTruments:SCAN[:STATe] <State>**

Starts a scan for the available extension instruments.

**Parameters:**

<State>            0 | 1 | OFF | ON  
                      **1**  
                      Starts scan.  
                      **0**  
                      Aborts scan.  
                      \*RST:        OFF

**Example:**            See [Chapter 11.1.5, "Enabling and Configuring an Extension Mode"](#), on page 197.

**Manual operation:** See "[Available Instruments](#)" on page 126

---

**:EXTension:INSTruments:REMOte:CHANnel?**

Queries the remote channels of the available extension instruments. Possible interfaces are: LAN, USB, SOCKet, PCIE.

**Parameters:**

<Channel> <Channellnstr#1>[,<Channellnstr#2>,...]

Returns a list of the used remote channels of the available extensions, one interface per instrument. If an extension uses more than one remote channels, the fastest one is returned.

**Example:**

See [Chapter 11.1.5, "Enabling and Configuring an Extension Mode"](#), on page 197.

**Usage:**

Query only

**Manual operation:**

See "[Available Instruments](#)" on page 126

**:EXTension:INSTRuments:REMote:LAN:NAME?**

Queries the IP addresses/instrument names of the available extension instruments.

**Return values:**

<IPAddress> <IPAdr\_Inst#1>[,<IPAdr\_Inst#2>,...]

**Example:**

See [Chapter 11.1.5, "Enabling and Configuring an Extension Mode"](#), on page 197.

**Usage:**

Query only

**Manual operation:**

See "[Available Instruments](#)" on page 126

**:EXTension:INSTRuments:REMote:SERial?**

Queiries the serial numbers of the available extension instruments.

**Parameters:**

<Serial> <SerialNumberInstr#1>[, <SerialNumberInstr#2>,...]

**Example:**

See [Chapter 11.1.5, "Enabling and Configuring an Extension Mode"](#), on page 197.

**Usage:**

Query only

**Manual operation:**

See "[Available Instruments](#)" on page 126

**:EXTension:BUSY[:STATe]?**

Queries the state of the extension instrument.

**Return values:**

<State> 0 | 1 | OFF | ON

**0**

The extension is connected to the master instrument and can be remotely operated.

**1**

The extension is busy, i.e. in standby or locked state, or is performing a time consuming operation.

**Example:** See [Chapter 11.1.5, "Enabling and Configuring an Extension Mode"](#), on page 197.

**Usage:** Query only

**Manual operation:** See ["Available Instruments"](#) on page 126

#### **:EXTension:SElect <SelNr>**

Selects an extension by its index number. The subsequent SCPI commands are related to this extension.

#### **Parameters:**

<SelNr>	float
	<b>0</b>
	no selection

**Example:** See [Chapter 11.1.5, "Enabling and Configuring an Extension Mode"](#), on page 197.

#### **:TEST:EXTension:CONNECTION?**

Returns the results of a test to all signal connections between the instrument and the extension.

#### **Return values:**

<State>	0   1   OFF   ON
	0: no error detected
	1: error detected

**Usage:** Query only

**Manual operation:** See ["Test Signal Connections"](#) on page 126

#### **:TEST:EXTension:CONNECTION:RF?**

Returns the results of a test of the RF signal connection to the extension. This query does not report errors to the SCPI error queue.

You can use this SCPI to detect which extension is physically connected to a device.

#### **Return values:**

<State>	0   1   OFF   ON
	0: no error detected
	1: error detected

**Usage:** Query only

**Manual operation:** See ["Test Signal Connections"](#) on page 126

## 11.9 MMEMory Subsystem

The MMEMory subsystem (**Mass Memory**) contains the commands for managing files and directories as well as for loading and storing complete instrument settings in files.

The files are stored on the internal flash memory of the instrument or on external USB memory devices.

The default directory is determined using the command `MMEMory:CDIR`.



Use the command `:SYSTEM:MMEMory:PATH:USER?` to query the path of the directory for user-defined data.

---



The `/opt` directory is a protected and therefore a not accessible system directory. The files on this directory contain data that must not be changed. Therefore, this directory should not be accessed, since reconstruction of the system partition will lead to data loss.

---

### 11.9.1 File Naming Conventions

To enable files in different file systems to be used, the following file naming conventions should be observed.

The file name can be of any length and is case-sensitive, meaning it is distinguished between uppercase and lowercase letters.

The file and the optional file extension are separated by a dot. All letters and numbers are permitted (numbers are, however, not permitted at the beginning of the file name). If possible, special characters should not be used. The use of the slashes "\" and "/" should be avoided since they are used in file paths. A number of names are reserved for the operating system, e.g. `CLOCK$`, `CON`, `AUX`, `COM1 . . . COM4`, `LPT1 . . . LPT3`, `NUL` and `PRN`.

In the R&S SGS all files in which lists and settings are stored are given a characteristic extension. The extension is separated from the actual file name by a dot (see [Chapter 11.9.2, "Extensions for User Files"](#), on page 214 for an overview of the file types).

The two characters "\*" and "?" function as "wildcards", meaning they are used for selecting several files. The "?" character represents exactly one character, while the "\*" character represents all characters up to the end of the file name. "\*.\*" therefore stands for all files in a directory.

When used in conjunction with the commands, the parameter `<file_name>` is specified as a string parameter with quotation marks. It can contain either the complete path including the drive, only the path and the file name, or only the file name. The file name must include the file extension. The same applies for the parameters `<directory_name>` and `<path>`.

Depending on how much information is provided, either the values specified in the parameter or the values specified with the command `MMEM:CDIR` (default directory) are used for the path and the drive settings in the commands.

Before the instrument settings can be stored in a file, they have to be stored in an intermediate memory using common command `*SAV <number>`. The specified number is subsequently used in the `:MMEMory:STORe:STATe` on page 221 command. Also, subsequently to loading a file with instrument settings with command `:MMEMory:LOAD:STATe` on page 219, these settings have to be activated with the common command `*RCL <number>`.

## 11.9.2 Extensions for User Files

The following table lists all available file extensions for user files.

*Table 11-1: Automatically assigned file extensions in the instrument*

Function	Contents	File suffix
R&S SGMA-GUI Save As/Open	Software settings	*.savrcl

## 11.9.3 Examples

In these examples, the current instrument setting is stored in the file `test.savrcltxt` in the directory `/var/sgs/..`

### Storing and Loading Current Settings

1. Store the current setting in an intermediate memory with the number 4. This setting can be called using command `*RCL` and the associated number of the memory, for example `*RCL 4`.  
`*SAV 4`
2. To store the settings in a file in a specific directory, specify the complete path.  
`MMEM:STOR:STAT 4, "/var/sgs/test.savrcltxt"`
3. To store the settings in a file in the default drive, set the default drive and specify only the file name.  
`MMEM:CDIR '/var/sgs/'*SAV 4`  
`MMEM:STOR:STAT 4, "test.savrcltxt"`
4. Load the file `test.savrcltxt` in the user directory.  
`MMEM:LOAD:STAT 4, '/var/sgs/test.savrcltxt'`
5. Activate the instrument setting of the file `test.savrcltxt`.  
`*RCL 4`

### Working with Files and Directories

1. Read out all files in the specified directory.  
`MMEM:CAT? 'usbuser'`

**Response:** 127145265,175325184,"test,DIR,0","temp,DIR,0",  
 "readme.txt,ASC,1324","state.savrcltxt,STAT,5327",  
 "waveform.wv,BIN,2342"

the directory `usbuser` contains the subdirectories `test` and `temp` as well as the files `readme.txt`, `state.savrcltxt` and `waveform.wv` which have different file types.

**Tip:** To query only the subdirectories of the current or specified directory, perform:  
 MMEM:DCAT? 'usbuser'

**Response:** 'test', 'temp'

To query only the number of subdirectories in the current or specified directory, perform:

MMEM:DCAT:LENG? 'usbuser'

**Response:** 2

2. To query the number of files in the current or specified directory, perform:

MMEM:CAT:LENG? 'usbuser'

**Response:** 3

3. Create a new subdirectory for mass memory storage in the specified directory.

MMEM:MDIR 'usbnew'

4. Copy the file `state` to a new file.

MMEM:COPY '/var/sgs/state.savrcltxt','usbnew'

5. Rename the file `state`.

MMEM:MOVE 'state.savrcltxt','state\_new.savrcltxt'

6. Remove the `test` directory.

MMEM:RDIR 'usbtest'

## 11.9.4 Remote Control Commands

:MMEMory:CATalog?	216
:MMEMory:CATalog:LENGth?	216
:MMEMory:CDIRectory	216
:MMEMory:COPI	217
:MMEMory:DATA	217
:MMEMory:DCATalog?	218
:MMEMory:DCATalog:LENGth?	218
:MMEMory:DELe	219
:MEMory:HFRee?	219
:MMEMory:LOAD:STATe	219
:MMEMory:MDIRectory	220
:MMEMory:MOVE	220
:MMEMory:MSIS	220
:MMEMory:RDIRectory	220
:MMEMory:STORe:STATe	221

---

**:MMEMory:CATalog?** <path>

Returns the content of a particular directory.

**Query parameters:**

<path>	string
--------	--------

String parameter to specify the directory. If you leave out the path, the command returns the contents of the directory selected with `:MMEMory:CDIRectory`. The path may be relative or absolute.

**Return values:**

<UsedDiskSpace>	Byte size of all files in the directory.
<FreeDiskSpace>	Remaining disk space in bytes.
<FileInfo>	<NameFileN>,<SuffixFileN>,<SizeFileN> List of files, separated by commas

**<NameFileN>**  
Name of the file.

**<SuffixFileN>**  
Type of the file. Possible suffixes are: ASCii, BINary, DIRectory

**<SizeFileN>**  
Size of the file in bytes.

**Example:** See "[Working with Files and Directories](#)" on page 214.

**Usage:** Query only

---

**:MMEMory:CATalog:LENGth?** <Path>

Returns the number of files in the current or in the specified directory.

**Query parameters:**

<Path>	string
--------	--------

String parameter to specify the directory. If the directory is omitted, the command queries the content of the current directory, queried with `:MMEMory:CDIRectory` command.

**Return values:**

<FileCount>	integer
-------------	---------

Number of files.

**Example:** See "[Working with Files and Directories](#)" on page 214.

**Usage:** Query only

---

**:MMEMory:CDIRectory** <Directory>

Changes the default directory for mass memory storage. The directory is used for all subsequent `MMEM` commands if no path is specified with them.

**Parameters:**

<Directory> <directory\_name>  
String containing the path to another directory. The path can be relative or absolute.  
To change to a higher directory, use two dots '..'.

**Example:** See ["Working with Files and Directories"](#) on page 214.

**Usage:** SCPI confirmed

**:MMEMory:COPY** <SourceFile>[,<DestinationFile>]

Copies an existing file to a new file. Instead of just a file, this command can also be used to copy a complete directory together with all its files.

**Setting parameters:**

<SourceFile> string  
String containing the path and file name of the source file

<DestinationFile> string  
String containing the path and name of the target file. The path can be relative or absolute.  
If <DestinationFile> is not specified, the <SourceFile> is copied to the current directory, queried with the [:MMEMory:CDIRectory](#) command.

**Note:** Existing files with the same name in the destination directory are overwritten without an error message.

**Example:** See ["Working with Files and Directories"](#) on page 214.

**Usage:** Setting only  
SCPI confirmed

**:MMEMory:DATA** <Filename>, <BinaryBlock>**:MMEMory:DATA?** <Filename>

The setting command writes the block data <BinaryBlock> to the file identified by <Filename>.

**Tip:** Use this command to read/transfer stored instrument settings or waveforms directly from/to the instrument.

**Parameters:**

<BinaryBlock> #<number><length\_entry><data>  
#: Hash sign; always comes first in the binary block  
<number>: the first digit indicates how many digits the subsequent length entry has  
<length\_entry>: indicates the number of subsequent bytes  
<data>: binary block data for the specified length.

For files with a size with more than nine digits (gigabytes), the instrument allows the syntax #(<Length>), where <Length> is the file size in decimal format.

**Parameters for setting and query:**

<Filename> string  
String parameter to specify the name of the file.

**Example:**

```
MMEMory:DATA '/var/sgs/test.txt',#15hallo
```

Writes the block data to the file `test.txt`.

The digit 1 indicates a length entry of one digit; the digit 5 indicate a length of the binary data (`hallo`) in bytes.

```
MMEMory:DATA? '/var/sgs/test.txt'
```

Sends the data of the file `test.txt` from the instrument to the controller in the form of a binary block.

```
Response: #15hallo
```

**Usage:** SCPI confirmed

**:MMEMory:DCATalog? <path>**

Returns the subdirectories of a particular directory.

**Query parameters:**

<path> String parameter to specify the directory. If the directory is omitted, the command queries the content of the current directory, queried with `:MMEMory:CDIRectory` command.

**Return values:**

<Catalog> <file\_entry>  
Names of the subdirectories separated by colons. The first two strings are related to the parent directory.

**Example:** See "[Working with Files and Directories](#)" on page 214.

**Usage:** Query only

**:MMEMory:DCATalog:LENGth? [<Path>]**

Returns the number of subdirectories in the current or specified directory.

**Query parameters:**

<Path> String parameter to specify the directory. If the directory is omitted, the command queries the contents of the current directory, to be queried with `:MMEMory:CDIRectory` command.

**Return values:**

<DirectoryCount> integer  
Number of parent and subdirectories.

**Example:** See "[Working with Files and Directories](#)" on page 214.

**Usage:** Query only

---

**:MMEMory:DELeTe** <Filename>

Removes a file from the specified directory.

**Setting parameters:**

<Filename> string  
String parameter to specify the name and directory of the file to be removed.

**Example:** See "[Working with Files and Directories](#)" on page 214.

**Usage:** Event  
SCPI confirmed

---

**:MEMory:HFRee?**

Returns the used and available memory in Kb.

**Return values:**

<TotalPhysMemKb> integer  
Total physical memory.

<ApplicMemKb> integer  
Application memory.

<HeapUsedKb> integer  
Used heap memory.

<HeapAvailableKb> integer  
Available heap memory.

**Usage:** Query only

---

**:MMEMory:LOAD:STATe** <SavRclStateNumb>, <file\_name>

Loads the specified file stored under the specified name in an internal memory.

After the file has been loaded, the instrument setting must be activated using an \*RCL command.

**Setting parameters:**

<SavRclStateNumb> Determines to the specific <number> to be used with the \*RCL command, e.g. \*RCL 4.

<file\_name> String parameter to specify the file name with extension \*.savrcltxt.

**Example:** See "[Storing and Loading Current Settings](#)" on page 214.

**Usage:** Setting only

---

**:MMEMory:MDIRectory** <Directory>

Creates a subdirectory for mass memory storage in the specified directory. If no directory is specified, a subdirectory is created in the default directory. This command can also be used to create a directory tree.

**Setting parameters:**

<Directory>                    string  
String parameter to specify the new directory.

**Example:**                    See "[Working with Files and Directories](#)" on page 214.

**Usage:**                      Event

---

**:MMEMory:MOVE** <SourceFile>, <DestinationFile>

Moves an existing file to a new location or, if no path is specified, renames an existing file.

**Setting parameters:**

<SourceFile>                    string  
String parameter to specify the name of the file to be moved.

<DestinationFile>                string  
String parameters to specify the name of the new file.

**Example:**                    See "[Working with Files and Directories](#)" on page 214.

**Usage:**                      Event  
SCPI confirmed

---

**:MMEMory:MSIS** <Msis>

Defines the drive or network resource (in the case of networks) for instruments with windows operating system, using `msis` (MSIS = Mass Storage Identification String).

**Note:** Instruments with Linux operating system ignore this command, since Linux does not use drive letter assignment.

**Usage:**                      SCPI confirmed

---

**:MMEMory:RDIRectory** <Directory>

Removes an existing directory from the mass memory storage system. If no directory is specified, the subdirectory with the specified name is deleted in the default directory.

**Setting parameters:**

<Directory>                    string  
String parameter to specify the directory to be deleted.

**Example:**                    See "[Working with Files and Directories](#)" on page 214.

**Usage:**                      Event

---

**:MMEMory:STORe:STATe** <savrcl\_state\_nr>, <file\_name>

Stores the current instrument setting in the specified file.

The instrument setting must first be stored in an internal memory with the same number using the common command \*SAV.

**Setting parameters:**

<savrcl\_state\_nr>      Corresponds to the specific <number> defined with the \*SAV command, e.g. \*SAV 4.

<file\_name>            String parameter to specify the file name with extension \*.savrcltxt.

**Example:**            See ["Storing and Loading Current Settings"](#) on page 214.

**Usage:**              Event

## 11.10 Fast Speed Commands

This section describes special commands that allow a fast frequency and level setting.

[:FFASt](#)..... 221  
[:PFAST](#)..... 221

---

**:FFASt** <Freq>

Special command to set the RF output frequency with minimum latency. No unit (e.g. Hz) allowed.

Bypasses the status system so command \*OPC? cannot be appended.

**Parameters:**

<Freq>                  float

**Example:**            FFAST 12750000000

---

**:PFAST** <Pow>

Special command to set the RF output level with minimum latency at the RF output connector. This value does not consider a specified offset. No unit (e.g. dBm) allowed.

Bypasses the status system so command \*OPC? cannot be appended.

**Parameters:**

<Pow>                    float

**Example:**            :PFAST -20

## 11.11 OUTPut Subsystem

:OUTPut:AFIXed:RANGe:LOWer?	222
:OUTPut:AFIXed:RANGe:UPPer?	222
:OUTPut:AMODe	222
:OUTPut[:STATe]:PON	223
:OUTPut[:STATe]	223

---

### :OUTPut:AFIXed:RANGe:LOWer?

Queries the minimum level which can be set without the attenuator being adjusted (Attenuator FIXed).

**Return values:**

<Lower> float  
Default unit: dBm

**Example:** See [Chapter 11.1.2, "Generating an I/Q Modulated Signal"](#), on page 193.

**Usage:** Query only

**Manual operation:** See "[Level Range](#)" on page 91

---

### :OUTPut:AFIXed:RANGe:UPPer?

Queries the maximum level which can be set without the attenuator being adjusted (Attenuator FIXed).

**Return values:**

<Upper> float  
Default unit: dBm

**Example:** See [Chapter 11.1.2, "Generating an I/Q Modulated Signal"](#), on page 193.

**Usage:** Query only

**Manual operation:** See "[Level Range](#)" on page 91

---

### :OUTPut:AMODe <AMode>

Switches the mode of the attenuator at the RF output.

**Parameters:**

<AMode> AUTO | FIXed | APASSive

**AUTO**

The attenuator is switched automatically. The level settings are made in the full range.

**APASsive**

The attenuator is switched automatically. The level settings are made only for the passive reference circuits. The high-level ranges are not available.

**FIXed**

The level settings are made without switching the attenuator. When this operating mode is switched on, the attenuator is fixed to its current position and the resulting variation range is defined.

\*RST: AUTO

**Example:** See [Chapter 11.1.2, "Generating an I/Q Modulated Signal"](#), on page 193.

**Manual operation:** See ["Mode"](#) on page 90

**:OUTPut[:STATe]:PON <Pon>**

Selects the state which the RF output assumes when the instrument is switched on.

**Parameters:**

<Pon> OFF | UNCHanged  
\*RST: UNCHanged

**Example:** See [Chapter 11.1.4, "Advanced Task for Optimizing Performance"](#), on page 196.

**Manual operation:** See ["Power-On State"](#) on page 92

**:OUTPut[:STATe] <State>**

Activates/ deactivates the RF output.

**Parameters:**

<State> 0 | 1 | OFF | ON

**Example:** See [Chapter 11.1.2, "Generating an I/Q Modulated Signal"](#), on page 193.

**Manual operation:** See ["RF On/Off"](#) on page 66

## 11.12 SENSe, READ, INITiate and SLISt Subsystems

These subsystems contain the commands for configuring the power measurements with R&S NRP power sensor connected to the R&S SGS.



The local state is set with the `INIT` command. Switching off the local state enhances the measurement performance. Measurements results can be retrieved in local state on or off.

Sensor parameters are set with the `SENSe` commands.

To start the measurement and retrieve the result, use the `:READ<ch>[:POWer]?` command.

Suffix	Value range	Description
SENSe<ch>	[1] to 4	Indicates the sensor Use the <code>:SLISt</code> commands to change the sensor mapping
READ<ch>	[1] to 4	Sensor assignment
INIate<hw>	[1] to 4	Sensor assignment
ELEMent<ch>	[1] to 25	Sensor mapping list

### Programming examples

#### Example: Detecting and assigning a power sensor

```
SLISt:LIST?
// Response: "NRP33SN-V-900007-USB Legacy","NRP-Z211-900001-USB Legacy"
// list of automatically detected sensors

SLISt:SCAN:STATE 1
// searches for sensors connected in the LAN or via the USBTMC protocol

SLISt:LIST?
// Response:
// "NRP33SN-V-900007-USB Legacy","NRP-Z211-900001-USB Legacy",
// "NRP33SN-V-900005-USBTMC","NRP33SN-V-900011-LAN"
// list of automatically detected sensors
// the list can contain more entries

SLISt:ELEMent3:MAPPING SENS1
// maps the third sensor from the list to the first sensor channel

SLISt:SENSor:MAP "NRPS18S-100654-USB Legacy", SENS3
// maps the sensor directly to channel 3
```

#### Example: Performing a simple power measurement

Prerequisite: The sensor is connected to the instrument and mapped to the first sensor channel.

```
:INITiate1:CONTinuous ON
//Switches the continous power measurement on

:READ1?
// Triggers the measurement and displays the results
```

**Example: Performing a power measurement with a fixed filter**

**Prerequisite:** The sensor is connected to the instrument and mapped to the first sensor channel.

```

SENSe1:SOURce RF
//Sensor measures the power of the RF signal

SENSe1:FILTer:TYPE NSRatio
//Selects fixed noise filter mode

SENSe1:FILTer:NSRatio 0.02 DB
//Sets the maximum noise component in the result to 0.02 DB

SENSe1:FILTer:NSRatio:MTIME 10
//Limits the settling time to 10 seconds.

:SENSe1:APERTure:DEFault:STATe 0
// Deactivates the default aperture time of the sensor

:SENSe1:APERTure:TIME 10e-6
// Sets the aperture time to 10 us

SENSe1:UNIT DBM
//Selects unit dBm for the measured value

:INITiate:CONTinuous ON
//Switches the continous power measurement on

:READ?
//Triggers the measurement and displays the results

```

:SLISt[:LIST]?.....	226
:SLISt:SCAN[:STATe].....	226
:SLISt:ELEMent<ch>:MAPPing.....	226
:SLISt:SENSor:MAP.....	227
:INITiate<hw>[:POWer]:CONTinuous.....	227
:READ<ch>[:POWer]?.....	227
:SENSe<ch>:UNIT[:POWer].....	228
:SENSe<ch>[:POWer]:APERTure:DEFault:STATe.....	228
:SENSe<ch>[:POWer]:APERTure:TIME.....	229
:SENSe<ch>[:POWer]:CORRection:SPDevice:SElect.....	229
:SENSe<ch>[:POWer]:CORRection:SPDevice:STATe.....	229
:SENSe<ch>[:POWer]:CORRection:SPDevice:LIST?.....	229
:SENSe<ch>[:POWer]:FILTer:LENGth:AUTO?.....	230
:SENSe<ch>[:POWer]:FILTer:LENGth[:USER].....	230
:SENSe<ch>[:POWer]:FILTer:NSRatio.....	231
:SENSe<ch>[:POWer]:FILTer:NSRatio:MTIME.....	231
:SENSe<ch>[:POWer]:FILTer:SONCe.....	231
:SENSe<ch>[:POWer]:FILTer:TYPE.....	232
:SENSe<ch>[:POWer]:FREQuency.....	232

:SENSe<ch>[:POWer]:LOGGing:STATe.....	233
:SENSe<ch>[:POWer]:OFFSet.....	233
:SENSe<ch>[:POWer]:OFFSet:STATe.....	233
:SENSe<ch>[:POWer]:SNUMber?.....	233
:SENSe<ch>[:POWer]:SOURce.....	234
:SENSe<ch>[:POWer]:STATus[:DEVice]?.....	234
:SENSe<ch>[:POWer]:SVERsion?.....	234
:SENSe<ch>[:POWer]:TYPE?.....	235
:SENSe<ch>[:POWer]:ZERO.....	235

---

### :SLISt[:LIST]?

Returns a list of all detected sensors in a comma-separated string.

#### Return values:

<SensorList>                      String of comma-separated entries

Each entry contains information on the sensor type, serial number and interface.

The order of the entries does not correspond to the order the sensors are displayed in the "NRP Sensor Mapping" dialog.

**Example:**                      See [Example "Detecting and assigning a power sensor"](#) on page 224.

**Usage:**                          Query only

**Manual operation:**    See " [Sensor Mapping List](#) " on page 104

---

### :SLISt:SCAN[:STATe] <State>

Starts the search for R&S NRP power sensors, connected in the LAN or via the USBTMC protocol.

#### Parameters:

<State>                              0 | 1 | OFF | ON

\*RST:                                0

**Example:**                      See [Example "Detecting and assigning a power sensor"](#) on page 224.

**Manual operation:**    See " [Scan](#) " on page 105

---

### :SLISt:ELEMent<ch>:MAPPING <Mapping>

Assigns an entry from the [:SLISt\[:LIST\]?](#) to one of the four sensor channels.

#### Parameters:

<Mapping>                            SENS1 | SENSor1 | SENS2 | SENSor2 | SENS3 | SENSor3 | SENS4 | SENSor4 | UNMapped

Sensor channel.

\*RST:                                UNMapped

**Example:** See [Example "Detecting and assigning a power sensor"](#) on page 224.

**Manual operation:** See "[Sensor Mapping List](#)" on page 104

**:SLISt:SENSor:MAP** <SensorId>, <Mapping>

Assigns a sensor directly to one of the sensor channels, using the sensor name and serial number.

To find out the the sensor name and ID, you can get it from the label of the R&S NRP, or using the command `:SLISt:SCAN[:STATe]`. This command detects all R&S NRP power sensors connected in the LAN or via 'USBTMC protocol.

**Setting parameters:**

<SensorId> string

<Mapping> enum

**Example:** See [Example "Detecting and assigning a power sensor"](#) on page 224.

**Usage:** Setting only

**Manual operation:** See "[Sensor Mapping List](#)" on page 104

**:INITiate<hw>[:POWER]:CONTInuous** <Continuous>

Switches the local state of the continuous power measurement by R&S NRP power sensors on and off. Switching off local state enhances the measurement performance during remote control.

The remote measurement is triggered with `:READ<ch>[:POWER]?`). This command also returns the measurement results. The local state is not affected, measurement results can be retrieved with local state on or off.

**Parameters:**

<Continuous> 0 | 1 | OFF | ON

\*RST: 0

**Example:** `INIT1:CONT ON`  
Switches local state of continuous power measurement on.

**Manual operation:** See "[State](#)" on page 109

**:READ<ch>[:POWER]?**

Triggers power measurement and displays the results.

**Note:** This command does not affect the local state, i.e. you can get results with local state on or off. For long measurement times, we recommend that you use an SRQ for command synchronization (MAV bit).

**Suffix:**

<ch> 1 to 3

**Return values:**

<Power> float or float,float

The sensor returns the result in the unit set with command :

[SENSe<ch>:UNIT\[:POWer\]](#)

Certain power sensors, such as the R&S NRP-Z81, return two values, first the value of the average level and - separated by a comma - the peak value.

**Example:**

```
SENS1:UNIT DBM
// Selects unit dBm for presentation of measurement result
READ1?
// Queries the measurement result of the sensor
// -45.6246576745440230
// -45.6 dBm were measured at the given frequency
```

**Example:**

```
R&S NRP-Z81
READ1?
-55.62403263352178,-22.419472478812476
-55.6 dBm is the measured average level, -22.4 dBm is the measured peak
```

**Usage:**

Query only

**Manual operation:** See "[Level \(Peak\) / Level \(Average\)](#)" on page 109

**:SENSe<ch>:UNIT[:POWer] <Power>**

Selects the unit (Watt, dBm or dBµV) of measurement result display, queried with :  
[READ<ch>\[:POWer\]?](#).

**Parameters:**

<Power> DBM | DBUV | WATT  
\*RST: DBM

**Example:**

```
SENS2:UNIT DBM
Selects dBm as unit for the measured value returned by com-
mand READ.
READ2?
Response: 7.34
7.34 dBm are measured by sensor 2.
```

**Manual operation:** See "[Level \(Peak\) / Level \(Average\)](#)" on page 109

**:SENSe<ch>[:POWer]:APERTure:DEFault:STATe <UseDefAp>**

Deactivates the default aperture time of the respective sensor.

To specify a user-defined value, use the command [:SENSe<ch>\[:POWer\]:APERTure:TIME](#) on page 229.

**Parameters:**

<UseDefAp> 0 | 1 | OFF | ON  
\*RST: 1

**Example:** See [Example "Performing a power measurement with a fixed filter"](#) on page 225.

**Manual operation:** See ["Default Aperture Time"](#) on page 111

**:SENSe<ch>[:POWer]:APERture:TIME <ApTime>**

Defines the aperture time (size of the acquisition interval) for the corresponding sensor.

**Parameters:**

<ApTime> float  
 Range: depends on connected power sensor  
 Increment: 1E-9  
 \*RST: depends on connected power sensor

**Example:** See [Example "Performing a power measurement with a fixed filter"](#) on page 225.

**Manual operation:** See ["Aperture Time"](#) on page 112

**:SENSe<ch>[:POWer]:CORRection:SPDevice:SELEct <Select>**

Several S-parameter tables can be stored in a sensor. The command selects a loaded data set for S-parameter correction for the corresponding sensor.

**Parameters:**

<Select> float  
 \*RST: 0

**Manual operation:** See [" S-Parameter "](#) on page 112

**:SENSe<ch>[:POWer]:CORRection:SPDevice:STATe <State>**

Activates the use of the S-parameter correction data.

**Note:** If you use power sensors with attenuator, the instrument automatically activates the use of S-parameter data.

**Parameters:**

<State> 0 | 1 | OFF | ON  
 \*RST: 0

**Example:** `SENSe1:POWer:CORRection:SPDevice:STATe 1`  
 Activates the use of the S-parameters correction data.

**Manual operation:** See [" S-Parameter "](#) on page 112

**:SENSe<ch>[:POWer]:CORRection:SPDevice:LIST?**

Queries the list of the S-parameter data sets that have been loaded to the power sensor.

**Return values:**

<List> string list  
 \*RST: 0

**Usage:** Query only

**Manual operation:** See "S-Parameter" on page 112

**:SENSe<ch>[:POWer]:FILTer:LENGth:AUTO?**

Queries the current filter length in filter mode AUTO (:SENSe<ch>[:POWer]:FILTer:TYPE)

**Return values:**

<Auto> float  
 Range: 1 to 65536

**Example:**

```
SENS1:FILT:TYPE AUTO
Selects auto filter.
SENS1:FILT:LENG:AUTO?
Queries the automatically set filter length.
Response: 1024
```

**Usage:** Query only

**Manual operation:** See "Filter Length" on page 111

**:SENSe<ch>[:POWer]:FILTer:LENGth[:USER] <User>**

Selects the filter length for SENS:POW:FILT:TYPE USER. As the filter length works as a multiplier for the time window, a constant filter length results in a constant measurement time (see also "About the measuring principle, averaging filter, filter length, and achieving stable results" on page 105).

The R&S NRP power sensors provide different resolutions for setting the filter length, depending on the used sensor type:

- Resolution = 1 for R&S NRPxx power sensors
- Resolution = 2<sup>n</sup> for sensors of the R&S NRP-Zxx family, with n = 1 to 16

**Parameters:**

<User> float  
 Range: 1 to 65536  
 \*RST: 1

**Example:**

```
SENS1:FILT:TYPE USER
Selects user filter mode.
SENS1:FILT:LENG 16
Sets a filter length of 16. E.g. using a sensor with 20 ms time window, the resulting measurement time is 640 ms (2x16x20 ms)
```

**Manual operation:** See "Filter Length" on page 111

**:SENSe<ch>[:POWer]:FILTer:NSRatio <NSRatio>**

Sets an upper limit for the relative noise content in fixed noise filter mode (:SENSe<ch>[:POWer]:FILTer:TYPE). This value determines the proportion of intrinsic noise in the measurement results.

**Parameters:**

<NSRatio> float  
 Range: 0.001 to 1  
 Increment: 0.001  
 \*RST: 0.01

**Example:** See [Example "Performing a power measurement with a fixed filter"](#) on page 225.

**Manual operation:** See ["Noise Content"](#) on page 111

**:SENSe<ch>[:POWer]:FILTer:NSRatio:MTIME <MTime>**

Sets an upper limit for the settling time of the auto-averaging filter in the NSRatio mode and thus limits the length of the filter. The filter type is set with command :SENSe<ch>[:POWer]:FILTer:TYPE.

**Parameters:**

<MTime> float  
 Range: 1 to 999.99  
 Increment: 0.01  
 \*RST: 4

**Example:** See [Example "Performing a power measurement with a fixed filter"](#) on page 225.

**Manual operation:** See ["Timeout"](#) on page 111

**:SENSe<ch>[:POWer]:FILTer:SONCe**

Starts searching the optimum filter length for the current measurement conditions. You can check the result with command :SENS1:POW:FILT:LENG:USER? in filter mode USER (:SENSe<ch>[:POWer]:FILTer:TYPE).

**Example:**

```
SENS1:FILT:TYPE USER
Selects user filter mode.
SENS1:FILT:SONC
Activates the search for the optimum filter length.
SENS1:FILT:LENG?
Returns the found optimum filter length.
Response: 128
```

**Usage:** Event

**Manual operation:** See ["Auto Once"](#) on page 111

**:SENSe<ch>[:POWer]:FILTer:TYPE <Type>**

Selects the filter mode. The filter length is the multiplier for the time window and thus directly affects the measurement time.

**Parameters:**

&lt;Type&gt;

AUTO | USER | NSRatio

**AUTO**

Automatically selects the filter length, depending on the measured value. The higher the power, the shorter the filter length, and vice versa.

**USER**

Allows you to set the filter length manually. As the filter-length takes effect as a multiplier of the measurement time, you can achieve constant measurement times.

**NSRatio**

Selects the filter length (averaging factor) according to the criterion that the intrinsic noise of the sensor (2 standard deviations) does not exceed the specified noise content. You can define the noise content with command `:SENSe<ch>[:POWer]:FILTer:NSRatio`.

**Note:** To avoid long settling times when the power is low, you can limit the averaging factor limited with the "timeout" parameter (`:SENSe<ch>[:POWer]:FILTer:NSRatio:MTIME`).

\*RST: AUTO

**Example:** See [Example "Performing a power measurement with a fixed filter"](#) on page 225.

**Manual operation:** See ["Filter"](#) on page 110

**:SENSe<ch>[:POWer]:FREQuency <Frequency>**

Sets the RF frequency of the signal, if signal source "USER" is selected (`:SENSe<ch>[:POWer]:SOURce`).

**Parameters:**

&lt;Frequency&gt;

float

\*RST: 1 GHz

**Example:**

SENS1:SOUR USER

Selects user-defined source.

SENS1:FREQ 2.44GHz

Sets the RF frequency of the source which is 2.44 GHz.

**Manual operation:** See ["Frequency"](#) on page 110

**:SENSe<ch>[:POWer]:LOGGing:STATe <State>**

Activates the recording of the power values, measured by a connected R&S NRP power sensor.

**Parameters:**

<State> 0 | 1 | OFF | ON  
\*RST: 0

**Example:**

SENS:LOGG:STAT ON  
Activates recording of the power measurement of the first sensor.

**Manual operation:** See ["Enable Logging"](#) on page 112

**:SENSe<ch>[:POWer]:OFFSet <Offset>**

Sets a level offset which is added to the measured level value after activation with command `:SENSe<ch>[:POWer]:OFFSet:STATe`. The level offset allows, e.g. to consider an attenuator in the signal path.

**Parameters:**

<Offset> float  
Range: -100.0 to 100.0  
\*RST: 0  
Default unit: dB

**Example:**

SENS1:POW:OFFS 10.0  
Sets a level offset of 10 dB

**Manual operation:** See ["Level Offset State,Level Offset"](#) on page 110

**:SENSe<ch>[:POWer]:OFFSet:STATe <State>**

Activates the addition of the level offset to the measured value. The level offset value is set with command `:SENSe<ch>[:POWer]:OFFSet`.

**Parameters:**

<State> 0 | 1 | OFF | ON  
\*RST: 0

**Example:**

SENS1:POW:OFFS 0.4dB  
Sets a level offset of 0.4 dB  
SENS1:POW:OFFS:STAT ON  
A level offset of 0.4 dB is added to the measured value.

**Manual operation:** See ["Level Offset State,Level Offset"](#) on page 110

**:SENSe<ch>[:POWer]:SNUMber?**

Queries the serial number of the sensor.

**Return values:**

<SNumber> string

**Example:**

SENS1:SNUM?  
Queries the serial number.

**Usage:**

Query only

**Manual operation:** See "[Sensor type and serial number](#)" on page 109

**:SENSe<ch>[:POWer]:SOURce <Source>**

Determines the signal to be measured.

**Note:** When measuring the RF signal, the sensor considers the corresponding correction factor at that frequency, and uses the level setting of the instrument as reference level.

**Parameters:**

<Source> A | USER | RF  
\*RST: A

**Example:**

See [Example "Performing a power measurement with a fixed filter"](#) on page 225.

**Manual operation:** See "[Source](#)" on page 110

**:SENSe<ch>[:POWer]:STATus[:DEVice]?**

Queries if a sensor is connected to the instrument.

**Return values:**

<Status> 0 | 1 | OFF | ON  
\*RST: 0

**Example:**

SENS1:STAT?  
Response: 1  
A sensor is connected.

**Usage:**

Query only

**Manual operation:** See "[State](#)" on page 109

**:SENSe<ch>[:POWer]:SVERsion?**

Queries the software version of the connected R&S NRP power sensor.

**Return values:**

<SVersion> string

**Example:**

SENS1:POW:SVER?  
Queries the software version of the power sensor.

**Usage:**

Query only

**:SENSe<ch>[:POWer]:TYPE?**

Queries the sensor type. The type is automatically detected.

**Return values:**

<Type> string

**Example:**

SENS1:TYPE?

Queries the type of sensor.

Response: NRP-Z21

The R&S NRP-Z21 sensor is used.

**Usage:** Query only

**Manual operation:** See " [Sensor type and serial number](#) " on page 109

**:SENSe<ch>[:POWer]:ZERO**

Performs zeroing of the sensor.

Zeroing is required after warm-up, i.e. after connecting the sensor.

**Note:** Switch off or disconnect the RF power source from the sensor before zeroing.

We recommend that you zero in regular intervals (at least once a day), if:

- The temperature has varied more than about 5 °C.
- The sensor has been replaced.
- You want to measure very low power.

**Example:**

SENS1:ZERO

Executes zeroing.

**Usage:** Event

**Manual operation:** See " [Zero](#) " on page 109

## 11.13 SOURce Subsystem

<a href="#">[:SOURce]:OPMode</a> .....	235
<a href="#">[:SOURce]:FREQuency[:CW FIXed]</a> .....	236
<a href="#">[:SOURce]:FREQuency:OFFSet</a> .....	236
<a href="#">[:SOURce]:LOSCillator:SOURce</a> .....	236
<a href="#">[:SOURce]:PATH:COUNT?</a> .....	237

**[:SOURce]:OPMode <OpMode>**

Sets the operation mode.

**Parameters:**

<OpMode> NORMal | BBBypass

**NORMal**

normal operation

**BBBypass**

Baseband bypass mode

\*RST: NORMal

**Example:** See [Chapter 11.1.2, "Generating an I/Q Modulated Signal"](#), on page 193.

**Manual operation:** See ["Operation Mode"](#) on page 80

**[ :SOURce]:FREQuency[:CW|FIXed] <Cw>**

Sets the RF frequency at the RF output connector of the selected instrument.

**Note:** Enabled frequency offset affects the result of this query. The query returns the frequency, including frequency offset.

See [\[:SOURce\]:FREQuency:OFFSet](#) on page 236.

**Parameters:**

<Cw> float  
\*RST: 1 GHz

**Example:** See [Chapter 11.1.2, "Generating an I/Q Modulated Signal"](#), on page 193.

**Manual operation:** See ["Freq/Freq \(Offs\)"](#) on page 66

**[ :SOURce]:FREQuency:OFFSet <Offset>**

Sets a frequency offset, for example include the frequency shift of downstream instrument.

**Note:** Enabled frequency offset affects the result of the query [:SOURce:FREQuency:CW?](#)

The query returns the frequency, including frequency offset.

**Parameters:**

<Offset> float  
Range: -3e9 to 3e9  
Increment: 0.001  
\*RST: 0

**Example:**

```
SOURce:FREQuency:OFFSet 0
SOURce:FREQuency:CW 6000000000
SOURce:FREQuency:OFFSet 20000000
SOURce:FREQuency:CW?
// 6020000000
```

**Manual operation:** See ["Offset"](#) on page 81

**[ :SOURce]:LOSCillator:SOURce <Source>**

Selects the source of the local oscillator signal.

**Parameters:**

<Source> INTernal | EXTernal  
 INT: use built in oscillator; EXT: use signal at [REF/LO IN] connector

**Example:** See [Chapter 11.1.2, "Generating an I/Q Modulated Signal"](#), on page 193.

**Manual operation:** See "[Source](#)" on page 83

**[[:SOURce]:]PATH:COUNT?**

Queries the number of installed RF paths.

**Return values:**

<Count> integer  
 Range: 1 to INT\_MAX  
 \*RST: 1

**Example:** PATH:COUN?  
 Queries the number of RF paths.  
 Response: 1  
 The instrument is equipped with one RF path.

**Usage:** Query only

## 11.14 SOURce:CORRection Subsystem

The output level is corrected in the CORRection subsystem. Correction is performed by user-defined table values being added to the output level for the respective RF frequency. In the R&S SGS, this subsystem is used to select, transfer and activate user correction tables.

Each list is stored as a file. The name of the user correction file can be freely selected. The file extension \*.uco is assigned automatically and cannot be changed.

The files can be stored in a freely selectable directory and opened from there. The default directory is set using command :MMEMory:CDIRectory on page 216. In the case of files which are stored in the default directory, only the file name has to be specified in commands. Otherwise, the complete absolute path has to be specified with every command. The extension can be omitted in any case.



In the following command examples, the files are stored in the default directory.

<a href="#">[:SOURce]:CORRection:CSET:CATalog?</a> .....	238
<a href="#">[:SOURce&lt;hw&gt;]:CORRection:CSET:DATA:FREQUency</a> .....	238
<a href="#">[:SOURce&lt;hw&gt;]:CORRection:CSET:DATA:FREQUency:POINts?</a> .....	239
<a href="#">[:SOURce&lt;hw&gt;]:CORRection:CSET:DATA:POWer</a> .....	239

<code>[SOURce&lt;hw&gt;]:CORRection:CSET:DATA:POWer:POINts?</code>	239
<code>[SOURce&lt;hw&gt;]:CORRection:CSET:DATA[:SENSor&lt;ch&gt;][:POWer]:SONCe</code>	240
<code>[SOURce]:CORRection:CSET:DELete</code>	240
<code>[SOURce&lt;hw&gt;]:CORRection:DEXChange:AFILe:CATalog?</code>	240
<code>[SOURce&lt;hw&gt;]:CORRection:DEXChange:AFILe:EXTension</code>	241
<code>[SOURce&lt;hw&gt;]:CORRection:DEXChange:AFILe:SELect</code>	241
<code>[SOURce&lt;hw&gt;]:CORRection:DEXChange:AFILe:SEParator:COLumn</code>	242
<code>[SOURce&lt;hw&gt;]:CORRection:DEXChange:AFILe:SEParator:DECimal</code>	242
<code>[SOURce&lt;hw&gt;]:CORRection:DEXChange:EXECute</code>	243
<code>[SOURce&lt;hw&gt;]:CORRection:DEXChange:MODE</code>	243
<code>[SOURce&lt;hw&gt;]:CORRection:DEXChange:SELect</code>	244
<code>[SOURce&lt;hw&gt;]:CORRection:CSET[:SELect]</code>	244
<code>[SOURce&lt;hw&gt;]:CORRection[:STATe]</code>	245
<code>[SOURce&lt;hw&gt;]:CORRection:VALue?</code>	245
<code>[SOURce&lt;hw&gt;]:CORRection:ZERoing:STATe</code>	245

---

### `[SOURce]:CORRection:CSET:CATalog?`

Requests a list of user correction tables. The individual lists are separated by commas.

The lists are stored with the fixed file extensions `*.uco` in a directory of the user's choice. The directory applicable to the commands is defined with the command `MMEMoRY:CDIR`.

#### Return values:

<Catalog> string

#### Example:

```
MMEM:CDIR '/var/sgs/ucor'
```

selects the directory for the user correction files.

```
CORR:CSET:CAT?
```

queries which correction tables are available.

```
Response:UCOR1,UCOR2,UCOR3
```

the correction tables `UCOR1`, `UCOR2` and `UCOR3` are available.

**Usage:** Query only

---

### `[SOURce<hw>]:CORRection:CSET:DATA:FREQUency <Frequency>`

Transfers the frequency data to the table selected with `:CORRection:CSET:SELect`.

The numerical suffix at `SOURce` must not be used for this command.

#### Parameters:

<Frequency> Frequency#1[, Frequency#2, ...]  
 Range: 300 kHz to RFmax (depending on model)

#### Example:

```
CORR:CSET '/var/sgs/ucor1'
```

selects the table `ucor1`.

```
CORR:CSET:DATA:FREQ 100MHz,102MHz,103MHz,...
```

enters the frequency value in the table `ucor1`.

**Manual operation:** See " [Edit User Cor. Data](#) " on page 95

**[ :SOURce<hw>]:CORRection:CSET:DATA:FREQuency:POINts?**

Queries the number of frequency values in the selected table.

The numerical suffix at SOURce must not be used for this command.

**Return values:**

<Points>                    integer  
                               Range:     0 to 10000  
                               \*RST:     0

**Example:**

```
CORR:CSET '/var/sgs/'
selects the table ucor1.
CORR:CSET:DATA:FREQ:POIN?
queries the number of frequency values in the table ucor1.
Response: 440
the table ucor1 contains 440 frequency values.
```

**Usage:**                    Query only

**[ :SOURce<hw>]:CORRection:CSET:DATA:POWer <Power>**

Transfers the level data to the table selected with [ :SOURce<hw>]:CORRection:CSET[:SELEct].

\*RST does not affect data lists. The numerical suffix at SOURce must not be used for this command.

**Parameters:**

<Power>                    Power#1[, Power#2, ...]

**Example:**

```
CORR:CSET '/var/sgs/ucor1'
selects the table ucor1.
CORR:CSET:DATA:POW 1dB, 0.8dB, 0.75dB,...
enters the level values in the table ucor1.
```

**Manual operation:**    See " [Edit User Cor. Data](#) " on page 95

**[ :SOURce<hw>]:CORRection:CSET:DATA:POWer:POINts?**

Queries the number of level values in the selected table.

The numerical suffix at SOURce must not be used for this command.

**Return values:**

<Points>                    integer  
                               Range:     0 to 10000  
                               \*RST:     0

**Example:**           CORR:CSET '/var/sgs/ucor1'  
selects the table ucor1.  
CORR:CSET:DATA:POW:POIN?  
queries the number of level values in the table ucor1.  
Response: 440  
the table ucor1 contains 440 level values.

**Usage:**             Query only

#### **[:SOURce<hw>]:CORRection:CSET:DATA[:SENSor<ch>][:POWER]:SONCe**

The command fills the selected user correction list with the level values measured by the power sensor for the given frequencies.

To select the used power sensor set the suffix in key word `SENSe`.

**Example:**           CORR:CSET:DATA:SENS:POW:SONC  
fills the user correction list with level values acquired by the power sensor connector to the [SENSOR] connector.

**Usage:**             Event

**Manual operation:** See "[Fill User Correction Data with Sensor](#)" on page 100

#### **[:SOURce]:CORRection:CSET:DELeTe <Filename>**

Deletes the specified table.

The lists are stored with the fixed file extensions `*.uco` in a directory of the user's choice. The directory applicable to the commands is defined with the command `MMEMory:CDIR`. A path can also be specified in command `SOUR:CORR:CSET:CAT?`, in which case the file in the specified directory is deleted.

#### **Setting parameters:**

<Filename>           <table name>

**Example:**           MMEM:CDIR '/var/sgs/ucor'  
selects the directory for the user correction files.  
CORR:CSET:DEL 'UCOR1'  
deletes the table ucor1.

**Usage:**             Setting only

**Manual operation:** See "[User Cor. Data](#)" on page 95

#### **[:SOURce<hw>]:CORRection:DEXChange:AFILe:CATalog?**

Requests a list of available ASCII files for export/import of user correction data. The individual files are separated by commas.

The ASCII files are stored with the fixed file extensions `*.txt` or `*.csv` in a directory of the user's choice. The directory applicable to the commands is defined with the command `MMEMory:CDIR`.

**Return values:**

<Catalog> string

**Example:**

```
MMEM:CDIR '/var/sgs/import'
```

selects the directory for the ASCII files with frequency and level value pairs.

```
CORR:DEXC:AFIL:EXT TXT
```

selects that ASCII files with extension \*.txt are listed.

```
CORR:DEXC:AFIL:CAT?
```

queries the available files with extension \*.txt.

```
Response: 'ucor1,ucor2'
```

the ASCII files ucor1.txt and ucor2.txt are available.

**Usage:**

Query only

**[:SOURce<hw>]:CORRection:DEXChange:AFIL:EXTension <Extension>**

Selects the file extension of the ASCII file to be imported or exported. Selection TXT (text file) or CSV (Excel file) is available.

**Parameters:**

<Extension> TXT | CSV

```
*RST:      TXT
```

**Example:**

```
MMEM:CDIR '/var/sgs/import'
```

selects the directory for the ASCII files with frequency and level value pairs.

```
CORR:DEXC:AFIL:EXT TXT
```

selects that ASCII files with extension \*.txt are listed.

```
CORR:DEXC:AFIL:CAT?
```

queries the available files with extension \*.txt.

```
Response: 'list1,list2'
```

the ASCII files ucor1.txt and ucor2.txt are available.

**Manual operation:** See "[Extension](#)" on page 97

**[:SOURce<hw>]:CORRection:DEXChange:AFIL:SElect <Filename>**

Selects the ASCII file to be imported or exported.

The ASCII files are stored with the fixed file extensions \*.txt or \*.csv in a directory of the user's choice. The directory applicable to the commands is defined with the command MMEMory:CDIR. A path can also be specified in command SOUR:CORR:DEXC:AFIL:SEL, in which case the files are stored or loaded in the specified directory.

**Parameters:**

<Filename> <ascii file name>

**Example:** `CORR:DEXC:MODE IMP`  
 selects that ASCII files with frequency and level value pairs are imported and transferred into user correction lists.  
`CORR:DEXC:AFIL:SEL '/var/sgs/import_ucor.csv'`  
 selects that ASCII file `ucor.csv` is imported.  
`CORR:DEXC:SEL '/var/sgs/import_ucor_imp'`  
 selects that the ASCII file `ucor.csv` is imported into user correction list `ucor_imp`.

**Manual operation:** See "[Select ASCII Source/Destination](#)" on page 98

**[:SOURCE<hw>]:CORREction:DEXChange:AFILe:SEParator:COLumn <Column>**

Selects the separator between the frequency and level column of the ASCII table.

**Parameters:**

<Column> TABulator | SEMicolon | COMMa | SPACe  
 \*RST: COMMa

**Example:** `CORR:DEXC:MODE EXP`  
 selects that the user correction list is exported into an ASCII file.  
`CORR:DEXC:AFIL:SEL '/var/sgs/import_ucor.csv'`  
 selects ASCII file `ucor.csv` as destination for the user correction list data.  
`CORR:DEXC:AFIL:SEP:COL TAB`  
 the pairs of frequency and level values are separated by a tabulator.  
`CORR:DEXC:AFIL:SEP:DEC DOT`  
 selects the decimal separator dot.  
`CORR:DEXC:SEL '/var/sgs/import_ucor_imp'`  
 selects that the user correction list `ucor_imp` is imported into ASCII file `ucor.csv`.

**Manual operation:** See "[Column Separator](#)" on page 97

**[:SOURCE<hw>]:CORREction:DEXChange:AFILe:SEParator:DECimal <Decimal>**

Selects the decimal separator used in the ASCII data between '.' (decimal point) and ',' (comma) with floating-point numerals.

**Parameters:**

<Decimal> DOT | COMMa  
 \*RST: DOT

**Example:**

```
CORR:DEXC:MODE EXP
```

selects that the user correction list is exported into an ASCII file.

```
CORR:DEXC:AFIL:SEL '/var/sgs/import_ucor.csv'
```

selects ASCII file ucor.csv as destination for the user correction list data.

```
CORR:DEXC:AFIL:SEP:COL TAB
```

the pairs of frequency and level values are separated by a tabulator.

```
CORR:DEXC:AFIL:SEP:DEC DOT
```

selects the decimal separator dot.

```
CORR:DEXC:SEL '/var/sgs/import_ucor_imp'
```

selects that the user correction list ucor\_imp is imported into ASCII file ucor.csv.

**Manual operation:** See "[Decimal Point](#)" on page 97

#### **[:SOURCE<hw>]:CORREction:DEXChange:EXECute**

Starts the export or import of the selected file. When import is selected, the ASCII file is imported as user correction list. When export is selected, the user correction list is exported into the selected ASCII file.

**Example:**

```
CORR:DEXC:MODE IMP
```

selects that ASCII files with frequency and level value pairs are imported and transferred into user correction lists.

```
CORR:DEXC:AFIL:SEL '/var/sgs/import_ucor.csv'
```

selects that ASCII file ucor.csv is imported.

```
CORR:DEXC:SEL '/var/sgs/import_ucor_imp'
```

selects that the ASCII file ucor.csv is imported into user correction list ucor\_imp.

```
CORR:DEXC:EXEC
```

starts the import of the ASCII file data into the user correction file.

**Usage:** Event

**Manual operation:** See "[Import/Export](#)" on page 98

#### **[:SOURCE<hw>]:CORREction:DEXChange:MODE <Mode>**

Selects if user correction lists should be imported or exported. Depending on the selection here, the file select command defines either the source or the destination for user correction lists and ASCII files.

**Parameters:**

```
<Mode>          IMPort | EXPort
*RST:           IMPort
```

**Example:**

```
CORR:DEXC:MODE IMP
selects that ASCII files with frequency and level value pairs are
imported and transferred into user correction lists.
CORR:DEXC:AFIL:SEL '/var/sgs/ucor.csv'
selects that ASCII file ucor.csv is imported.
CORR:DEXC:SEL '/var/sgs/ucor_imp'
selects that the ASCII file ucor.csv is imported into user cor-
rection list ucor_imp.
```

**Manual operation:** See "[Mode](#)" on page 97

### **[ :SOURCE<hw>]:CORREction:DEXChange:SElect <Filename>**

Selects the user correction list to be imported or exported.

The user correction files are stored with the fixed file extensions \*.uco in a directory of the user's choice. The directory applicable to the commands is defined with the command `MMEMORY:CDIR`. A path can also be specified in command `SOUR:CORR:DEXC:SEL`, in which case the files are stored or loaded in the specified directory.

**Parameters:**

<Filename>                    string

**Example:**

```
CORR:DEXC:MODE IMP
selects that ASCII files with frequency and level value pairs are
imported and transferred into user correction lists.
CORR:DEXC:AFIL:SEL '/var/sgs/import_ucor.csv'
selects that ASCII file ucor.csv is imported.
CORR:DEXC:SEL '/var/sgs/import_ucor_imp'
selects that the ASCII file ucor.csv is imported into user cor-
rection list ucor_imp.
```

**Manual operation:** See "[Select Destination/Source](#)" on page 98

### **[ :SOURCE<hw>]:CORREction:CSET[:SElect] <Filename>**

Selects or creates a file for the user correction data.

If the file does not exist, the instrument automatically creates a new file with the name you assigned. Note the predefined file extensions under [Chapter 11.9.2, "Extensions for User Files"](#), on page 214.

To determine the file location (directory/path) you can either enter it with the command directly, or use the command `MMEMORY:CDIR`.

To activate level correction use the command `[ :SOURCE<hw>]:CORREction[: STATE]`.

**Parameters:**

<Filename>                    <table name>

**Example:**           CORR:CSET '/var/sgs/ucor1'  
selects the table ucor1.  
CORR ON  
activates level correction. Correction is performed using the  
table ucor1.

**Manual operation:** See " [User Cor. Data](#) " on page 95

#### **[:SOURce<hw>]:CORRection[:STATe] <State>**

Activates/deactivates level correction. Level correction is performed using the table which has been selected with the command `[ :SOURce<hw> ]:CORRection:CSET[ :SElect ]`.

**Parameters:**

<State>           0 | 1 | OFF | ON  
\*RST:            0

**Example:**           SOUR:CORR:CSET '/var/sgs/ucor1'  
selects the table ucor1.  
SOUR:CORR ON  
activates user correction.

**Manual operation:** See " [State](#) " on page 94

#### **[:SOURce<hw>]:CORRection:VALue?**

Queries the current value for user correction.

**Return values:**

<Value>           float  
Range:           -100 to 100  
Increment:       0.01  
\*RST:            0

**Example:**           CORR:VAL?  
queries the value currently used for level correction.  
Response: -3  
the correction value is - 3 dB.

**Usage:**            Query only

**Manual operation:** See " [User Correction](#) " on page 94

#### **[:SOURce<hw>]:CORRection:ZERoing:STATe <State>**

Activates the zeroing procedure before filling the user correction data acquired by a sensor.

**Parameters:**

<State>           0 | 1 | OFF | ON  
\*RST:            1

**Manual operation:** See "Fill User Correction Data with Sensor" on page 100

## 11.15 SOURce:IQ Subsystem

<a href="#">[:SOURce]:IQ:STATe</a> .....	246
<a href="#">[:SOURce]:IQ:IMPAirment:IQRatio[:MAGNitude]</a> .....	246
<a href="#">[:SOURce]:IQ:IMPAirment:LEAKage:I</a> .....	246
<a href="#">[:SOURce]:IQ:IMPAirment:LEAKage:Q</a> .....	246
<a href="#">[:SOURce]:IQ:IMPAirment:QUADrature[:ANGLE]</a> .....	247
<a href="#">[:SOURce]:IQ:IMPAirment[:STATe]</a> .....	247
<a href="#">[:SOURce]:IQ:CRESTfactor</a> .....	247
<a href="#">[:SOURce]:IQ:WBSTate</a> .....	248

---

### **[:SOURce]:IQ:STATe <State>**

Switches the I/Q modulation on and off.

**Parameters:**

<State>                    0 | 1 | OFF | ON  
 \*RST:                    0

**Example:** See [Chapter 11.1.2, "Generating an I/Q Modulated Signal"](#), on page 193.

**Manual operation:** See "[Mod State](#)" on page 66

---

### **[:SOURce]:IQ:IMPAirment:IQRatio[:MAGNitude] <IqRatio>**

Sets the ratio of I modulation to Q modulation (amplification "imbalance"). The input may be either in dB or %. The resolution is 0.001 dB, an input in percent is rounded to the closest valid value in dB. A query returns the value in dB.

**Parameters:**

<IqRatio>                    float  
 Range:                    -1 to 1  
 Increment:                1E-3  
 \*RST:                    0

**Example:** See [Chapter 11.1.2, "Generating an I/Q Modulated Signal"](#), on page 193.

**Manual operation:** See "[Gain Imbalance](#)" on page 122

---

### **[:SOURce]:IQ:IMPAirment:LEAKage:I <I>**

### **[:SOURce]:IQ:IMPAirment:LEAKage:Q <Q>**

Sets the carrier leakage amplitude for the I-signal/ Q-signal component.

**Parameters:**

<Q> float  
 Range: -5 to 5  
 Increment: 0.01  
 \*RST: 0  
 Default unit: PCT

**Example:** See [Chapter 11.1.2, "Generating an I/Q Modulated Signal"](#), on page 193.

**Manual operation:** See ["Offset"](#) on page 122

**[:SOURce]:IQ:IMPairment:QUADrature[:ANGLE] <Angle>**

Sets the quadrature offset for the digital I/Q signal.

**Parameters:**

<Angle> float  
 Range: -8 to 8  
 Increment: 0.01  
 \*RST: 0  
 Default unit: DEG

**Example:** See [Chapter 11.1.2, "Generating an I/Q Modulated Signal"](#), on page 193.

**Manual operation:** See ["Quadrature Offset"](#) on page 123

**[:SOURce]:IQ:IMPairment[:STATE] <State>**

Activates/ deactivates the three impairment or correction values LEAKage, QUADrature and IQRatio for the baseband signal prior to input into the I/Q modulator.

**Parameters:**

<State> 0 | 1 | OFF | ON  
 \*RST: 0

**Example:** See [Chapter 11.1.2, "Generating an I/Q Modulated Signal"](#), on page 193.

**Manual operation:** See ["State"](#) on page 122

**[:SOURce]:IQ:CREStfactor <CrestFactor>**

Sets the crest factor of the IQ modulation signal.

**Parameters:**

<CrestFactor> float  
 Range: 0 to 80  
 Increment: 0.01  
 \*RST: 0  
 Default unit: dB

**Example:** see [Chapter 11.1.2, "Generating an I/Q Modulated Signal"](#), on page 193

**Manual operation:** See "[Crest Factor](#)" on page 121

**[ :SOURce]:IQ:WBStAtE <State>**

Selects optimized settings for wideband modulation signals.

**Parameters:**

<State> 0 | 1 | OFF | ON  
\*RST: 0

**Example:** See [Chapter 11.1.2, "Generating an I/Q Modulated Signal"](#), on page 193.

**Manual operation:** See "[I/Q Wideband](#)" on page 121

## 11.16 SOURce:PHASe Subsystem

[\[:SOURce\]:PHASe.....](#) 248

[\[:SOURce\]:PHASe:REFerence.....](#) 248

**[ :SOURce]:PHASe <Phase>**

Specifies the phase variation relative to the current phase.

**Parameters:**

<Phase> float  
Range: -360 to 360  
Increment: 0.1  
\*RST: 0  
Default unit: DEG

**Example:** See [Chapter 11.1.2, "Generating an I/Q Modulated Signal"](#), on page 193.

**Manual operation:** See "[Delta Phase](#)" on page 82

**[ :SOURce]:PHASe:REFerence**

Adopts the phase set with command `[ :SOURce ] : PHASe` as the current phase.

**Example:** See [Chapter 11.1.2, "Generating an I/Q Modulated Signal"](#), on page 193.

**Usage:** Event

**Manual operation:** See "[Reset Delta Phase Display](#)" on page 82

## 11.17 SOURce:POWer Subsystem

<a href="#">[:SOURce]:POWer:ALC:DSEnsitivity</a> .....	249
<a href="#">[:SOURce]:POWer:ALC[:STATe]</a> .....	249
<a href="#">[:SOURce]:POWer:ALC:SONCe</a> .....	249
<a href="#">[:SOURce]:POWer:ATTenuation:RFOFF:MODE</a> .....	250
<a href="#">[:SOURce]:POWer:ATTenuation:SOVer[:OFFSet]</a> .....	250
<a href="#">[:SOURce]:POWer:LMODe</a> .....	250
<a href="#">[:SOURce]:POWer:POWer</a> .....	250
<a href="#">[:SOURce]:POWer:SCHaracteristic</a> .....	251
<a href="#">[:SOURce]:POWer[:LEVel][:IMMediate][:AMPLitude]</a> .....	251
<a href="#">[:SOURce]:POWer[:LEVel][:IMMediate]:OFFSet</a> .....	252
<a href="#">[:SOURce]:POWer:LIMit[:AMPLitude]</a> .....	252
<a href="#">[:SOURce]:POWer:PEP?</a> .....	252
<a href="#">[:SOURce]:POWer:RANGe:LOWer?</a> .....	253
<a href="#">[:SOURce]:POWer:RANGe:UPPer?</a> .....	253

---

### **[:SOURce]:POWer:ALC:DSEnsitivity** <Sensitivity>

Sets the power detector sensitivity. Used for compatibility reasons only.

#### **Parameters:**

<Sensitivity>            OFF | LOW | MED | HIGH  
 \*RST:                  OFF

**Manual operation:**    See "[Detector Sensitivity](#)" on page 93

---

### **[:SOURce]:POWer:ALC[:STATe]** <State>

Activates/deactivates automatic level control.

#### **Parameters:**

<State>                  1 | OFFTable | OFF | ONTable | AUTO | ON  
 \*RST:                  ONTable

**Example:**                See [Chapter 11.1.2, "Generating an I/Q Modulated Signal"](#),  
 on page 193.

**Manual operation:**    See "[State](#)" on page 93

---

### **[:SOURce]:POWer:ALC:SONCe**

Briefly activates level control for correction purposes.

**Usage:**                  Event

**Manual operation:**    See "[Readjust](#)" on page 90

---

**[:SOURce]:POWer:ATTenuation:RFOff:MODE <Mode>**

Determines the attenuator's state after the instrument is switched on.

**Parameters:**

<Mode> MAX | FATTenuated | FIXed | UNCHanged

**MAX = FATTenuated**

Sets attenuation to maximum when the RF signal is switched off. This setting is recommended for applications that require a high level of noise suppression.

**FIXed = UNCHanged**

Retains the current setting and keeps the output impedance constant during RF off.

\*RST: n.a. (factory preset: MAX)

**Manual operation:** See "[RF-Off-Mode](#)" on page 91

---

**[:SOURce]:POWer:ATTenuation:SOVer[:OFFSet] <Offset>**

Sets the switch-over offset value of the attenuator.

**Parameters:**

<Offset> float  
Range: -10 to 10  
Increment: 0.1  
\*RST: 0

**Manual operation:** See "[SATT Switch-Over Offset](#)" on page 91

---

**[:SOURce]:POWer:LMODe <LevMode>**

Selects the level mode.

**Parameters:**

<LevMode> NORMal | LNOise | LDISTortion  
**NORM**  
automatic selection of the best settings  
**LNOISE**  
settings for lowest noise  
**LDISTortion**  
settings for lowest distortions

**Example:** See [Chapter 11.1.4, "Advanced Task for Optimizing Performance"](#), on page 196.

**Manual operation:** See "[Mode](#)" on page 89

---

**[:SOURce]:POWer:POWer <Amplitude>**

Sets the level at the RF output connector.

This value does not consider a specified offset. The command `[ :SOURce ] :POWer [ :LEVel ] [ :IMMediate ] [ :AMPLitude ]` sets the level of the "Level" display, that means the level containing offset.

**Parameters:**

<Amplitude> float  
 Range: -20 to 25  
 Increment: 0.01  
 \*RST: -10

**Example:**

POW:POW 15  
 sets the RF level at output to 15 dBm.

**Manual operation:** See "[Level/Level Offset](#)" on page 66

**[ :SOURce ] :POWer :SCHaracteristic <Characteristic>**

Selects the characteristic for the level setting.

**Parameters:**

<Characteristic> AUTO | UNINterrupted | CVSWr | USER | MONotone  
**UNINterrupted**  
 uninterrupted level setting  
**CVSWr**  
 constant-VSWR  
**MONotone**  
 strictly monotone  
 \*RST: AUTO

**Example:**

See [Chapter 11.1.4, "Advanced Task for Optimizing Performance"](#), on page 196.

**Manual operation:** See "[Setting Characteristic](#)" on page 89

**[ :SOURce ] :POWer [ :LEVel ] [ :IMMediate ] [ :AMPLitude ] <Amplitude>**

Sets the RF level at the RF output connector of the instrument.

**Parameters:**

<Amplitude> float  
 Range: -20 to 25  
 Increment: 0.01  
 \*RST: -10

**Example:**

See [Chapter 11.1.4, "Advanced Task for Optimizing Performance"](#), on page 196.

**Manual operation:** See "[Level/Level Offset](#)" on page 66

---

**[ :SOURce]:POWer[:LEVel][:IMMediate]:OFFSet <Offset>**

**Note:** The level offset is also effective for level sweeps!

The command specifies the constant level offset of a downstream attenuator/amplifier. If a level offset is entered, the level entered with `[ :SOURce] :POWer :POWer` no longer corresponds to the RF output level.

The following correlation applies:

$$:POWer = \text{RF output level} + :POWer:OFFSet.$$

Entering a level offset does not change the RF output level, but rather the query value of `:POWer`.

**Parameters:**

<Offset>	float
Range:	-100 to 100
Increment:	0.1
*RST:	0

**Manual operation:** See ["Offset"](#) on page 88

---

**[ :SOURce]:POWer:LIMit[:AMPLitude] <Amplitude>**

Sets the upper limit of the RF signal power.

The value is not affected by an instrument preset and \*RST function. This parameter is influenced only by the factory preset (`SYST:FPR`) and its factory value is equal to the upper limit.

**Parameters:**

<Amplitude>	float
Range:	-120 to 25
Increment:	0.01
Default unit:	dBm

**Example:** See [Chapter 11.1.4, "Advanced Task for Optimizing Performance"](#), on page 196.

**Manual operation:** See ["Limit"](#) on page 90

---

**[ :SOURce]:POWer:PEP?**

Queries the RF signal's peak envelope power.

**Return values:**

<PEP>	float
-------	-------

**Example:** see [Chapter 11.1.2, "Generating an I/Q Modulated Signal"](#), on page 193

**Usage:** Query only

**Manual operation:** See ["PEP"](#) on page 66

**[:SOURce]:POWer:RANGe:LOWer?**

**[:SOURce]:POWer:RANGe:UPPer?**

Queries the minimum/maximum level range in the current level mode

**Return values:**

<Upper> float

**Usage:** Query only

**Manual operation:** See "[Level Range](#)" on page 89

## 11.18 SOURce:PULM Subsystem

This subsystem contains the commands for setting the pulse modulation.

### Programming Examples

#### Example: Performing pulse modulation

This example shows a command sequence to perform pulse modulation.

```
// *****
// Reset the instrument to start from an initial state
// *****
*RST; *CLS

// *****
// Set the RF signal frequency and level
// *****
SOURce:FREQuency:CW 4000000000
SOURce:POWer:LEVel:IMMediate:AMPLitude -25

// *****
// Configure the pulse modulation settings
// *****
// Select the internal modulation generator
SOURce:PULM:SOURce INT
// Set trigger mode
SOURce:PULM:TRIGger:MODE AUTO
// Select pulse mode
SOURce:PULM:MODE DOUB

// *****
// Alternatively configure the pulse modulation settings for
// external modulation source
// *****
// Select the external modulation source
SOURce:PULM:SOURce EXT
```

```

// Set the polarity of the externally applied modulation signal.
SOURce:PULM:POLarity NORMal
// Select the impedance for the external pulse modulation trigger input
SOURce:PULM:TRIGger:EXTernal:IMPedance G10K

// *****
// Configure the pulse generator settings
// *****
// Set pulse period
SOURce:PULM:PERiod 10 us
// Set pulse width
SOURce:PULM:WIDTH 8 us
// Set double pulse width
SOURce:PULM:DOUBle:WIDTH 0.0000012
// Set double pulse delay
SOURce:PULM:DOUBle:DELay 0.0000045

// *****
// Activate the signal output
// *****
SOURce:PGENERator:OUTPut:STATe 1
SOURce:PULM:STATe 1
OUTPut1:STATe 1

```

### Example: Generating a pulse train signal

This example shows a command sequence to create a pulse train signal.



Prior to the selection of the pulse train mode make sure that you have generated and selected a pulse train data list. Otherwise, the instrument generates an error.

```

// *****
// Reset the instrument to start from an initial state
// *****
*RST; *CLS

// *****
// Set the RF signal frequency and level
// *****
SOURce:FREQuency:CW 4000000000
SOURce:POWer:LEVel:IMMediate:AMPLitude -25

// *****
// Create a pulse train data list
// *****
// Select the directory
MMEM:CDIR '/var/user/Lists/'
// Create and/or select the pulse train data file

```

```

SOURce:PULM:TRain:SEL `P_FIVE`
// Enter the pulse train data
SOURce:PULM:TRain:ONTime 10ns,30ns,40ns,20ns,10ns
SOURce:PULM:TRain:OFFTime 30ns,40ns,50ns,40ns,30ns
SOURce:PULM:TRain:REPetition 10,1,3,10,6

// *****
// Select pulse train mode
// *****
// Select the internal modulation generator and the pulse mode
SOURce:PULM:SOURce INTernal
SOURce:PULM:MODE PTRain

// *****
// Activate the signal output
// *****
SOURce:PGENerator:OUTPut:STATe 1
SOURce:PULM:STATe 1
OUTPut1:STATe 1
    
```

[:SOURce<hw>]:PULM:DELay.....	255
[:SOURce<hw>]:PULM:DOUBle:DELay.....	256
[:SOURce<hw>]:PULM:DOUBle:WIDTh.....	256
[:SOURce<hw>]:PULM:MODE.....	256
[:SOURce<hw>]:PULM:PERiod.....	256
[:SOURce<hw>]:PULM:POLarity.....	257
[:SOURce<hw>]:PULM:SOURce.....	257
[:SOURce<hw>]:PULM:STATe.....	257
[:SOURce<hw>]:PULM:TRIGger:EXTernal:GATE:POLarity.....	258
[:SOURce<hw>]:PULM:TRIGger:EXTernal:IMPedance.....	258
[:SOURce<hw>]:PULM:TRIGger:EXTernal:SLOPe.....	258
[:SOURce<hw>]:PULM:TRIGger:MODE.....	258
[:SOURce<hw>]:PULM:WIDTh.....	259

**[:SOURce<hw>]:PULM:DELay <Delay>**

Sets the pulse delay.

**Parameters:**

<Delay>	float
	Range: 0 to 100 s
	Increment: 10 ns
	*RST: 10 ns

**Example:**

PULM:DEL 13 us  
 13 us elapse after a trigger before the first pulse is generated.

**Manual operation:** See "Pulse Delay" on page 116

---

**[:SOURce<hw>]:PULM:DOUBLE:DELay <Delay>**

Sets the delay from the start of the first pulse to the start of the second pulse.

**Parameters:**

<Delay> float  
 Range: 40 ns to 100 s  
 Increment: 10 ns  
 \*RST: 1 ns

**Example:** PULM:DOUB:DEL 22 us  
 22 us elapse between the beginning of the first pulse and the beginning of the second pulse in double-pulse mode.

**Manual operation:** See ["Double Pulse Delay"](#) on page 116

---

**[:SOURce<hw>]:PULM:DOUBLE:WIDTh <Width>**

Sets the width of the second pulse in case of double pulse generation.

**Example:** PULM:DOUB:WIDT 33 us  
 sets a width of 33 us for the second pulse.

**Manual operation:** See ["Double Pulse Width"](#) on page 115

---

**[:SOURce<hw>]:PULM:MODE <Mode>**

Sets the mode of the pulse generator.

**Parameters:**

<Mode> SINGle | DOUBle  
**SINGle**  
 Enables single pulse generation.  
**DOUBle**  
 Enables double pulse generation. The two pulses are generated in one pulse period.  
 \*RST: SINGle

**Example:** PULM:MODE DOUB  
 enables double pulse generation.

**Manual operation:** See ["Pulse Mode"](#) on page 115

---

**[:SOURce<hw>]:PULM:PERiod <Period>**

Sets the period of the generated pulse. The period determines the repetition frequency of the internal signal.

**Example:** PULM:PER 220 us  
 the pulse period is 220 us.

**Manual operation:** See ["Pulse Period"](#) on page 115

---

**[:SOURce<hw>]:PULM:POLarity <Polarity>**

Sets the polarity of the pulse modulator signal. This command is effective only for an external modulation signal.

**Parameters:**

<Polarity>                    NORMal | INVerted

**NORMal**

The RF signal is suppressed during the pulse pause.

**INVerted**

The RF signal is suppressed during the pulse.

\*RST:            NORMal

**Example:**

PULM:SOUR EXT

selects the external modulation source.

**Example:**

PULM:POL INV

selects inverted polarity.

**Manual operation:** See "[Polarity](#)" on page 114

---

**[:SOURce<hw>]:PULM:SOURce <Source>**

Selects the source for pulse modulation.

**Parameters:**

<Source>                    INTernal | EXTernal

**INTernal**

The internal pulse generator is used for the pulse modulation.

**EXTernal**

The signal applied externally via the trigger connector is used for the pulse modulation.

\*RST:            INTernal

**Manual operation:** See "[Source](#)" on page 114

---

**[:SOURce<hw>]:PULM:STATe <State>**

Activates the pulse modulation.

**Parameters:**

<State>                    0 | 1 | OFF | ON

\*RST:            0

**Example:**

PULM:STAT ON

activates pulse modulation.

**Manual operation:** See "[State](#)" on page 114

---

**[:SOURce<hw>]:PULM:TRIGger:EXTernal:GATE:POLarity <Polarity>**

Selects the polarity of the Gate signal.

**Parameters:**

<Polarity>            NORMal | INVerted  
\*RST:                NORMal

**Example:**

PULM:TRIG:EXT:GATE:POL NORM  
The pulse signal is generated while the gate signal is high.

**Manual operation:** See "[Gate Input Polarity](#)" on page 117

---

**[:SOURce<hw>]:PULM:TRIGger:EXTernal:IMPedance <Impedance>**

Selects the impedance for external pulse trigger.

**Parameters:**

<Impedance>        G50 | G10K  
\*RST:                G50

**Example:**

SOUR:PULM:TRIG:EXT:IMP G50  
selects 50 Ohm as the trigger impedance for the external pulse trigger.

**Manual operation:** See "[External Impedance](#)" on page 114

---

**[:SOURce<hw>]:PULM:TRIGger:EXTernal:SLOPe <Slope>**

Sets the polarity of the active slope of an externally applied trigger signal.

**Parameters:**

<Slope>             NEGative | POSitive  
\*RST:                POSitive

**Example:**

PULM:TRIG:EXT:SLOP NEG  
The pulse generator is triggered on the negative slope of the external trigger signal.

**Manual operation:** See "[Ext. Trigger Input Slope](#)" on page 117

---

**[:SOURce<hw>]:PULM:TRIGger:MODE <Mode>**

Selects the trigger mode for pulse modulation.

**Parameters:**

<Mode>              AUTO | EXTernal | EGATe

**AUTO**

The pulse modulation is generated continuously.

**EXTernal**

The pulse modulation is triggered by an external trigger event.  
The trigger signal is supplied via the trigger connector.

**EGATe**

The pulse modulation is gated by an external gate signal. The trigger signal is supplied via the trigger connector.

\*RST: AUTO

**Example:**

```
PULM:TRIG:MODE EXT
selects triggering by an external trigger event.
```

**Manual operation:** See ["Trigger Mode"](#) on page 117

**[SOURce<hw>]:PULM:WIDTh <Width>**

Sets the width of the generated pulse. The width determines the pulse length. The pulse width must be at least 20ns less than the set pulse period.

**Parameters:**

<Width>	float
Range:	20 ns to 100 s
Increment:	10 ns
*RST:	2 us

**Example:**

```
PULM:WIDTh 33 us
sets a width of 33 us for the pulse.
```

**Manual operation:** See ["Pulse Width"](#) on page 115

## 11.19 SOURce:ROSCillator Subsystem

<a href="#">[:SOURce]:ROSCillator:EXTernal:FREQUency</a> .....	259
<a href="#">[:SOURce]:ROSCillator:OUTPut:FREQUency</a> .....	260
<a href="#">[:SOURce]:ROSCillator:SOURce</a> .....	260
<a href="#">[:SOURce]:ROSCillator[:INTernal]:ADJust:VALue</a> .....	260
<a href="#">[:SOURce]:ROSCillator[:INTernal]:ADJust[:STATe]</a> .....	260
<a href="#">[:SOURce]:ROSCillator:EXTernal:SBANdwidth</a> .....	261

**[SOURce]:ROSCillator:EXTernal:FREQUency <ExtFreq>**

Selects the frequency of the external reference.

**Parameters:**

<ExtFreq>	10MHZ   100MHZ   1000MHZ   13MHZ
-----------	----------------------------------

13MHZ requires RF board with part number 1419.5308.02.  
 To find out the RF board installed in the instrument:  
 Select "SGMA-GUI > instrument name > Setup > Hardware Config" > ["RF Assembly"](#)  
 Observe the part number of the assembly "RfBoard".

**Example:**

See [Chapter 11.1.4, "Advanced Task for Optimizing Performance"](#), on page 196.

**Manual operation:** See ["Ext. Ref. Input Frequency"](#) on page 85

---

**[[:SOURce]:ROSCillator:OUTPut:FREQuency <OutputFreq>**

Selects the output for the reference oscillator signal.

**Parameters:**

<OutputFreq> 10MHZ | 100MHZ | 1000MHZ | 13MHZ  
13MHZ requires RF board with part number 1419.5308.02.

**Example:** See [Chapter 11.1.4, "Advanced Task for Optimizing Performance"](#), on page 196.

**Manual operation:** See ["Output Frequency"](#) on page 86

---

**[[:SOURce]:ROSCillator:SOURce <Source>**

Select the reference oscillator signal source.

**Parameters:**

<Source> INTernal | EXTernal

**Example:** See [Chapter 11.1.2, "Generating an I/Q Modulated Signal"](#), on page 193.

**Manual operation:** See ["Ref. Oscillator Source/Ext Ref On/Off"](#) on page 67

---

**[[:SOURce]:ROSCillator[:INTernal]:ADJust:VALue <Value>**

Allows an application to shift the reference oscillator frequency by a small amount.

The setting range depends on the reference oscillator type and its factory calibration value. Allowed are the following ranges:

- For TCXO oscillator: Max - Min = 1023
- For OCXO oscillator: Max - Min = 65535 (option R&S SGS-B1 required.)

**Parameters:**

<Value> integer  
Range: Min to Max  
\*RST: 0

**Example:** See [Chapter 11.1.4, "Advanced Task for Optimizing Performance"](#), on page 196.

**Manual operation:** See ["DAC Value"](#) on page 87

---

**[[:SOURce]:ROSCillator[:INTernal]:ADJust[:STATe] <State>**

Determines whether the calibrated (OFF) or a user-defined (ON) adjustment value is used for fine adjustment of the frequency.

If user-defined values are used, the instrument is no longer in the calibrated state. However, the calibration value is not changed and the instrument resumes the calibrated state after sending the com-

mand :SOURce:ROSCillator:INTernal:ADJust:STATe OFF.

**Parameters:**

<State> 0 | 1 | OFF | ON  
 \*RST: n.a. (factory preset: 0)

**Example:**

ROSC:SOUR INT  
 Selects the internal source.  
 ROSC:ADJ ON  
 Activates use of a user-defined adjustment value.  
 ROSC:ADJ:VAL 1400  
 Sets the adjustment value to 1400.

**Manual operation:** See ["Adjustment Active"](#) on page 87

**[:SOURce]:ROSCillator:EXTernal:SBANdwidth <SBandwidth>**

Sets the synchronization bandwidth for an external reference signal.

**Parameters:**

<SBandwidth> WIDE | NARRow  
**NARRow**  
 The synchronization bandwidth is 40 Hz.  
**WIDE**  
 Synchronization bandwidth is 250 Hz.  
 \*RST: n.a. (factory preset)

**Example:**

ROSC:SOUR EXT  
 Selects the external source.  
 ROSC:EXT:FREQ 10 MHz  
 Informs the instrument that the external reference has a frequency of 10 MHz.  
 ROSC:EXT:SBAN WID  
 Selects wideband setting for synchronization bandwidth.

**Manual operation:** See ["Synchronization Bandwidth"](#) on page 85

## 11.20 STATus Subsystem

This system contains the commands for the status reporting system. See also [Chapter A.5, "Status Reporting System"](#), on page 302 for detailed information.

\*RST on page 202 has no effect on the status registers.

**Value ranges**

- Queries return the current value of the respective register, which permits a check of the device status.  
 Return values: A decimal value in the range 0 to 32767 ( $=2^{15}-1$ )
- The configuration commands set the respective register thus determining which status changes of the R&S SGS cause the status registers to be changed.

Setting values: A decimal value in the range 0 to 32767 ( $=2^{15}-1$ )

:STATus:OPERation:CONDition?	262
:STATus:OPERation:ENABle	262
:STATus:OPERation[:EVENT]	262
:STATus:OPERation:NTRansition	263
:STATus:OPERation:PTRansition	263
:STATus:PRESet	263
:STATus:QUEStionable:CONDition	263
:STATus:QUEStionable:ENABle	264
:STATus:QUEStionable[:EVENT]	264
:STATus:QUEStionable:NTRansition	264
:STATus:QUEStionable:PTRansition	264
:STATus:QUEue[:NEXT]?	265

---

### :STATus:OPERation:CONDition?

Queries the content of the CONDition part of the STATus:OPERation register.

This part contains information on the action currently being performed in the instrument. The content is not deleted after being read out because it indicates the current hardware status.

#### Return values:

<Condition>                    string

**Example:**                    :STATus:OPERation:CONDition?

**Usage:**                        Query only

---

### :STATus:OPERation:ENABle <Enable>

Sets the bits of the ENABle part of the STATus:OPERation register. This setting determines which events of the Status-Event part are forwarded to the sum bit in the status byte. These events can be used for a service request.

#### Parameters:

<Enable>                        string

**Example:**                    :STAT:OPER:ENAB 32767  
all events are forwarded to the sum bit of the status byte.

---

### :STATus:OPERation[:EVENT] <Event>

Queries the content of the EVENT part of the STATus:OPERation register. This part contains information on the actions performed in the instrument since the last readout. The content of the EVENT part is deleted after being read out.

#### Parameters:

<Event>                         string

**Example:**                    :STAT:OPER:EVEN?  
queries the STATus:OPERation:EVENT register.

**:STATus:OPERation:NTRansition** <Ntransition>

Sets the bits of the NTRansition part of the STATus:OPERation register. If a bit is set, a transition from 1 to 0 in the condition part causes an entry to be made in the EVENT part of the register. The disappearance of an event in the hardware is thus registered, for example the end of an adjustment.

**Parameters:**

<Ntransition>            string

**Example:**

`:STAT:OPER:NTR 0`

a transition from 1 to 0 in the condition part of the Status:Operation register does not cause an entry to be made in the EVENT part.

**:STATus:OPERation:PTRansition** <Ptransition>

Sets the bits of the PTRansition part of the STATus:OPERation register. If a bit is set, a transition from 0 to 1 in the condition part causes an entry to be made in the EVENT part of the register. A new event in the hardware is thus registered, for example the start of an adjustment.

**Parameters:**

<Ptransition>            string

**Example:**

`:STAT:OPER:PTR 32767`

all transitions from 0 to 1 in the condition part of the Status:Operation register cause an entry to be made in the EVENT part.

**:STATus:PRESet** <Preset>

Resets the status registers. All PTRansition parts are set to FFFFh (32767), i.e. all transitions from 0 to 1 are detected. All NTRansition parts are set to 0, i.e. a transition from 1 to 0 in a CONDition bit is not detected. The ENABLE parts of STATus:OPERation and STATus:QUEStionable are set to 0, i.e. all events in these registers are not passed on.

**Parameters:**

<Preset>                string

**Example:**

`STAT:PRES`

resets the status registers.

**:STATus:QUEStionable:CONDition** <Condition>

Queries the content of the CONDition part of the STATus:QUEStionable register. This part contains information on the action currently being performed in the instrument. The content is not deleted after being read out since it indicates the current hardware status.

**Parameters:**

<Condition>            string

**Example:**                   :STATus:QUEStionable:CONDition?  
queries the Status:Questionable:Condition register.

**:STATus:QUEStionable:ENABle** <Enable>

Sets the bits of the ENABle part of the STATus:QUEStionable register. The enable part determines which events of the STATus:EVENT part are enabled for the summary bit in the status byte. These events can be used for a service request.

If a bit in the ENABle part is 1, and the corresponding EVENT bit is true, a positive transition occurs in the summary bit. This transition is reported to the next higher level.

**Parameters:**

<Enable>                   string

**Example:**                   STAT:QUES:ENAB 1  
Problems when performing an adjustment cause an entry to be made in the sum bit.

**:STATus:QUEStionable[:EVENT]** <Event>

Queries the content of the EVENT part of the STATus:QUEStionable register. This part contains information on the actions performed in the instrument since the last readout. The content of the EVENT part is deleted after being read out.

**Parameters:**

<Event>                   string

**Example:**                   STAT:QUES:EVENT?  
queries the Status:Questionable:Event register.

**:STATus:QUEStionable:NTRansition** <Ntransition>

Sets the bits of the NTRansition part of the STATus:QUEStionable register. If a bit is set, a transition from 1 to 0 in the condition part causes an entry to be made in the EVENT part of the register.

**Parameters:**

<Ntransition>           string

**Example:**                   STAT:QUES:NTR 0  
a transition from 1 to 0 in the condition part of the STATus:QUEStionable register does not cause an entry to be made in the EVENT part

**:STATus:QUEStionable:PTRansition** <PTransition>

Sets the bits of the PTRansition part of the STATus:QUEStionable register. If a bit is set, a transition from 1 to 0 in the condition part causes an entry to be made in the EVENT part of the register.

**Parameters:****<PTransition>** string**Example:**

STAT:QUES:PTR 32767

all transitions from 0 to 1 in the condition part of the STATus:QUESTionable register cause an entry to be made in the EVENT part

**:STATus:QUEue[:NEXT]?**

Queries the oldest entry in the error queue and then deletes it. Positive error numbers denote device-specific errors, and negative error numbers denote error messages defined by SCPI. If the error queue is empty, 0 ("No error") is returned.

The command is identical to :SYSTem:ERRor[:NEXT]? on page 268.

**Return values:****<Next>** string**Example:**

:STATus:QUEue?

queries the oldest entry in the error queue.

Response: 0, 'no error'

no errors have occurred since the error queue was last read out

**Usage:**

Query only

## 11.21 SYSTem Subsystem

The SYSTem subsystem contains a series of commands for general functions which do not directly affect signal generation.

:SYSTem:EMODE.....	266
:SYSTem:ERRor:ALL?.....	266
:SYSTem:ERRor:CODE:ALL?.....	267
:SYSTem:ERRor:CODE[:NEXT]?.....	267
:SYSTem:ERRor:COUNT?.....	268
:SYSTem:ERRor[:NEXT]?.....	268
:SYSTem:SERRor?.....	268
:SYSTem:VERSion?.....	269
:SYSTem:COMMunicate:NETWork:IPAdDress.....	269
:SYSTem:COMMunicate:NETWork:IPAdDress:MODE.....	269
:SYSTem:COMMunicate:NETWork:MACAdDress.....	270
:SYSTem:COMMunicate:NETWork:STATus?.....	270
:SYSTem:COMMunicate:NETWork:RESart.....	270
:SYSTem:COMMunicate:NETWork[:COMMon]:HOSTname.....	270
:SYSTem:COMMunicate:NETWork[:IPAdDress]:GATeway.....	270
:SYSTem:COMMunicate:NETWork[:IPAdDress]:SUBNet:MASK.....	271
:SYSTem:COMMunicate:NETWork:RESource?.....	271
:SYSTem:COMMunicate:SERial:BAUD.....	271
:SYSTem:COMMunicate:SERial:PARity.....	271

:SYSTem:COMMunicate:SERial:RESource?	272
:SYSTem:COMMunicate:SERial:SBITS	272
:SYSTem:COMMunicate:HISLip:RESource?	272
:SYSTem:COMMunicate:PClexpress:RESource?	272
:SYSTem:COMMunicate:SOCKet:PORT	273
:SYSTem:COMMunicate:SOCKet:RESource?	273
:SYSTem:COMMunicate:USB:RESource?	273
:SYSTem:REBoot	273
:SYSTem:REStart	274
:SYSTem:SHUTdown	274
:SYSTem:STARtup:COMPLetE?	274
:SYSTem:PROTect<ch>[:STATe]	274
:SYSTem:HARDware:ASSEMBly<dir>:NAME?	275
:SYSTem:HARDware:ASSEMBly<dir>:PNUMber?	275
:SYSTem:HARDware:ASSEMBly<dir>:REVision?	275
:SYSTem:HARDware:ASSEMBly<dir>:SNUMber?	276
:SYSTem:SOFTware:OPTion<dir>:DESignation?	276
:SYSTem:SOFTware:OPTion<dir>:EXPIration?	276
:SYSTem:SOFTware:OPTion<dir>:LICenses?	277
:SYSTem:SOFTware:OPTion<dir>:NAME?	277
:SYSTem:MMEMory:PATH:USER?	277
:SYSTem:OSYStem?	277

---

#### :SYSTem:EMODe <Mode>

Enables and selects the Eco Mode. With enabled eco mode `EM1` the doubler stage in a 12 GHz instrument is permanently switched off to reduce power consumption and the maximum frequency is limited to 6 GHz.

#### Parameters:

<Mode>                    OFF | EM1  
 \*RST:                    OFF

**Example:**                see [Chapter 11.1.1, "Performing General Task for Instrument Setup"](#), on page 191

---

#### :SYSTem:ERRor:ALL?

Queries the error/event queue for all unread items and removes them from the queue.

#### Return values:

<All>                      string  
 Error/event\_number,"Error/event\_description>[;Device-depend-ent info]"  
 A comma separated list of error number and a short description of the error in FIFO order.  
 If the queue is empty, the response is 0, "No error"  
 Positive error numbers are instrument-dependent. Negative error numbers are reserved by the SCPI standard.

Volatile errors are reported once, at the time they appear. Identical errors are reported repeatedly only if the original error has already been retrieved from (and hence not any more present in) the error queue.

**Example:** `SYST:ERR:ALL?`  
 Queries all entries in the error queue.  
 Response: 0, 'no error'  
 No errors have occurred since the error queue was last read out.

**Usage:** Query only

#### **:SYSTem:ERRor:CODE:ALL?**

Queries the error numbers of all entries in the error queue and then deletes them.

##### **Return values:**

<All> string  
 Returns the error numbers. To retrieve the entire error text, send the command `:SYSTem:ERRor:ALL?`.

**0**  
 "No error", i.e. the error queue is empty

**Positive value**  
 Positive error numbers denote device-specific errors

**Negative value**  
 Negative error numbers denote error messages defined by SCPI.

**Example:** `SYST:ERR:CODE:ALL`  
 Queries all entries in the error queue.  
 Response: 0  
 No errors have occurred since the error queue was last read out.

**Usage:** Query only

#### **:SYSTem:ERRor:CODE[:NEXT]?**

Queries the error number of the oldest entry in the error queue and then deletes it.

##### **Return values:**

<Next> string  
 Returns the error number. To retrieve the entire error text, send the command `:SYSTem:ERRor:ALL?`.

**0**  
 "No error", i.e. the error queue is empty

**Positive value**  
 Positive error numbers denote device-specific errors

**Negative value**  
 Negative error numbers denote error messages defined by SCPI.

**Example:**            `SYST:ERR:CODE`  
 Queries the oldest entry in the error queue.  
 Response: 0  
 No errors have occurred since the error queue was last read out.

**Usage:**            Query only

#### **:SYSTEM:ERROR:COUNT?**

Queries the number of entries in the error queue.

**Return values:**

<Count>            integer

**0**

The error queue is empty.

**Example:**            `SYST:ERR:COUN`  
 Queries the number of entries in the error queue.  
 Response: 1  
 One error has occurred since the error queue was last read out.

**Usage:**            Query only

#### **:SYSTEM:ERROR[:NEXT]?**

Queries the error/event queue for the oldest item and removes it from the queue.

**Return values:**

<Next>            string

Error/event\_number,"Error/event\_description>[;Device-dependent info]"

Error number and a short description of the error.

If the queue is empty, the response is 0, "No error"

Positive error numbers are instrument-dependent. Negative error numbers are reserved by the SCPI standard.

Volatile errors are reported once, at the time they appear. Identical errors are reported repeatedly only if the original error has already been retrieved from (and hence not any more present in) the error queue.

**Example:**            `SYST:ERR?`  
 Queries the oldest entry in the error queue.  
 Response: 0, 'no error'  
 No errors have occurred since the error queue was last read out.

**Usage:**            Query only

#### **:SYSTEM:SERROR?**

Returns a list of all errors existing at the time when the query is started. This list corresponds to the display on the info page under manual control.

**Return values:**

<Serror> string

**Example:**

SYST:SErr

queries all errors existing in the error queue.

**Example:**

Response: -221, 'Settings conflict', 153,  
'Input voltage out of range'

The two returned errors have occurred since the error queue was last queried.

**Usage:**

Query only

**:SYSTem:VERSion?**

Queries the SCPI version the instrument's command set complies with.

**Return values:**

<Version> string

**Example:**

SYST:VERS

queries the SCPI version.

Response: "1996"

The instrument complies with the SCPI version from 1996.

**Usage:**

Query only

**:SYSTem:COMMunicate:NETWork:IPAddress <IpAddress>**

Sets the IP address.

**Parameters:**

<IpAddress> string

Range: 0.0.0.0. to ff.ff.ff.ff

**Example:**

SYSTem:COMMunicate:NETWork:IPAddress "7.8.9.10"  
sets the IP address of the instrument.

**Manual operation:** See ["IP Address"](#) on page 141

**:SYSTem:COMMunicate:NETWork:IPAddress:MODE <Mode>**

Selects manual or automatic setting of the IP address.

**Parameters:**

<Mode> AUTO | STATic

\*RST: n.a. (factory preset: AUTO)

**Example:**

SYSTem:COMMunicate:NETWork:IPAddress:MODE AUTO

The IP address is assigned automatically (DHCP)

**Manual operation:** See ["Address Mode"](#) on page 140

---

**:SYSTem:COMMunicate:NETWork:MACAddress <MacAddress>**

Queries the MAC address of the network adapter.

**Parameters:**

<MacAddress>            string

**Example:**

SYST:COMM:NETW:MAC  
queries the MAC address.

---

**:SYSTem:COMMunicate:NETWork:STATus?**

Queries the network configuration state.

**Return values:**

<State>                    0 | 1 | OFF | ON

**Usage:**

Query only

---

**:SYSTem:COMMunicate:NETWork:REStart**

Restarts the network connection to the instrument, terminates the connection and sets it up again.

**Example:**

SYSTem:COMMunicate:NETWork:REStart

**Usage:**

Event

---

**:SYSTem:COMMunicate:NETWork[:COMMOn]:HOSTname <Hostname>**

Sets the individual host name of the R&S SGS.

**Note:** it is recommended that you do not change the host name in order to avoid problems with the network connection. However, if you change the host name be sure to use an unique name.

The host name is a protected parameter, To change it, first disable protection level 1 with command `:SYSTem:PROTECT<ch>[:STATe]` on page 274.

**Parameters:**

<Hostname>                string

**Example:**

SYSTem:PROTECT1:STATe OFF,123456  
SYSTem:COMMunicate:NETWork:HOSTname 'SIGGEN'  
sets the individual computer name of the R&S SGS.

**Manual operation:** See "[Hostname](#)" on page 140

---

**:SYSTem:COMMunicate:NETWork[:IPADdress]:GATeway <Gateway>**

Sets the IP address of the default gateway.

**Parameters:**

<Gateway> string  
 Range: 0.0.0.0 to ff.ff.ff

**Example:**

SYSTem:COMMunicate:NETWork:IPAddress:GATeway  
 '1.2.3.4'  
 sets the IP address of the default gateway.

**Manual operation:** See ["Default Gateway"](#) on page 141

**:SYSTem:COMMunicate:NETWork[:IPAddress]:SUBNet:MASK <Mask>**

Sets the subnet mask.

**Parameters:**

<Mask> string

**Example:**

SYSTem:COMMunicate:NETWork:IPAddress:SUBNet:  
 MASK '255.255.0.0'  
 determines the subnet mask.

**Manual operation:** See ["Subnet Mask"](#) on page 141

**:SYSTem:COMMunicate:NETWork:RESource?**

Queries the VISA resource string, used for remote control of the instrument with VXI-11 protocol.

**Return values:**

<Resource> string

**Example:**

SYSTem:COMMunicate:NETWork:RESource?  
 Response: "TCPIP::192.1.2.3::INSTR"

**Usage:**

Query only

**Manual operation:** See ["Visa Resource Strings"](#) on page 142

**:SYSTem:COMMunicate:SERial:BAUD <Baud>**

Sets the baudrate for the serial remote control interface.

**Parameters:**

<Baud> 2400 | 4800 | 9600 | 19200 | 38400 | 57600 | 115200  
 \*RST: n.a. (factory preset: 115200)

**Example:**

SYSTem:COMMunicate:SERial:BAUD 115200  
 Sets 115200 baudrate.

**:SYSTem:COMMunicate:SERial:PARity <Parity>**

Sets the parity for the serial remote control interface.

**Parameters:**

<Parity> NONE | ODD | EVEN  
 \*RST: n.a. (factory preset: NONE)

**Example:**

SYST:COMM:SER:PAR NONE  
 Selects parity NONE.

**:SYSTem:COMMunicate:SERial:RESource?**

Queries the VISA resource string for the serial remote control interface. This string is used for remote control of the instrument.

**Return values:**

<Resource> string

**Example:**

SYSTem:COMMunicate:SERial:RESource?  
 queries the VISA resource string.  
 Response: "ASRL1::INSTR"

**Usage:**

Query only

**:SYSTem:COMMunicate:SERial:SBITs <SBits>**

Sets the number of stop bits for the serial remote control interface.

**Parameters:**

<SBits> 1 | 2  
 \*RST: n.a. (factory preset: 1)

**Example:**

SYST:COMM:SER:SBIT 2  
 Selects 2 stop bits.

**:SYSTem:COMMunicate:HISLip:RESource?**

Queries the VISA resource string, used for remote control of the instrument with HiSLIP protocol.

**Return values:**

<Resource> string

**Example:**

SYSTem:COMMunicate:HISLip:RESource?  
 Response: "TCPIP::192.1.2.3::hislip0::INSTR"

**Usage:**

Query only

**Manual operation:**

See "[Visa Resource Strings](#)" on page 142

**:SYSTem:COMMunicate:PClExpress:RESource?**

Queries the visa resource string for remote control via the PCIe interface.

**Return values:**

<Resource> string

**Usage:** Query only  
**Manual operation:** See "[Visa Resource Strings](#)" on page 142

#### **:SYSTem:COMMunicate:SOCKet:PORT <ScpiEthPort>**

Sets the port number for remote control via socket communication.

**Parameters:**

<ScpiEthPort> integer  
 Range: 1000 to 65535  
 \*RST: n.a. (factory preset: 5025)

**Example:** `SYSTem:COMMunicate:SOCKet:PORT 5030`  
`// specifies the socket port number.`

**Manual operation:** See "[SCPI Port](#)" on page 61

#### **:SYSTem:COMMunicate:SOCKet:RESource?**

Queries the VISA resource string for remote control via LAN interface, using TCP/IP socket protocol.

**Return values:**

<Resource> string

**Example:** `SYSTem:COMMunicate:SOCKet:RESource?`  
 Response: "TCPIP::10.113.1.150::5025::SOCKET"

**Usage:** Query only

**Manual operation:** See "[Visa Resource Strings](#)" on page 142

#### **:SYSTem:COMMunicate:USB:RESource?**

Queries the VISA resource string for remote control via the USB interface.

**Return values:**

<Resource> string

**Example:** `SYSTem:COMMunicate:USB:RESource?`  
 queries the VISA resource string for remote control via the USB interface.  
 Response: "USB::72::000000::INSTR"

**Usage:** Query only

**Manual operation:** See "[Visa Resource Strings](#)" on page 142

#### **:SYSTem:REBoot**

Restarts the firmware and the operating system.

**Usage:** Event

---

**:SYSTem:REStart**

Restarts the firmware. The operating system remains active.

**Usage:** Event

---

**:SYSTem:SHUTdown**

Shuts down the instrument.

**Usage:** Event

---

**:SYSTem:STARtup:COMPLet?**

Queries if the startup of the instrument is completed.

**Return values:**

<Complete> 0 | 1 | OFF | ON  
\*RST: 0

**Example:**

```
SYST:STAR:COMP?  
// 1  
// the startup of the instrument is completed
```

**Usage:** Query only

---

**:SYSTem:PROTect<ch>[:STATe] <State>[, <Key>]**

Activates and deactivates the specified protection level.

**Suffix:**

<ch> Indicates the protection level.

**Parameters:**

<State> select  
\*RST: n.a. (factory preset: 1)

**Setting parameters:**

<Key> integer

The respective functions are disabled when the protection level is activated. No password is required for activation of a level. A password must be entered to deactivate the protection level. The password for the first level is 123456.

**Example:**

```
// to activate protection level  
SYSTem:PROTect1:STATe 1  
// internal adjustments or hostname cannot be changed  
// to unlock protection level 1  
SYSTem:PROTect1:STATe 0,123456  
// internal adjustments are accessible
```

---

**:SYSTem:HARDware:ASSEMBly<dir>:NAME?**

The query returns a list of hardware assembly names.

**Suffix:**

<dir> 1..2  
Defines the section: 1 = common assembly, 2 = RF assembly.

**Return values:**

<Name> string

**Example:** See [Chapter 11.1.1, "Performing General Task for Instrument Setup"](#), on page 191.

**Usage:** Query only

**Manual operation:** See ["Assembly"](#) on page 131

---

**:SYSTem:HARDware:ASSEMBly<dir>:PNUMBER?**

The query returns the list of hardware module part numbers.

**Suffix:**

<dir> 1..2  
Defines the section: 1 = common assembly, 2 = RF assembly.

**Return values:**

<PNumber> string

**Example:** See [Chapter 11.1.1, "Performing General Task for Instrument Setup"](#), on page 191.

**Usage:** Query only

**Manual operation:** See ["Assembly"](#) on page 131

---

**:SYSTem:HARDware:ASSEMBly<dir>:REVISION?**

Queries the list of hardware module revisions.

**Suffix:**

<dir> 1..2  
Defines the section: 1 = common assembly, 2 = RF assembly.

**Return values:**

<Revision> string

**Example:** See [Chapter 11.1.1, "Performing General Task for Instrument Setup"](#), on page 191.

**Usage:** Query only

**Manual operation:** See ["Assembly"](#) on page 131

---

**:SYSTem:HARDware:ASSEMBly<dir>:SNUMber?**

Queries the list of hardware module serial numbers.

**Suffix:**

<dir> 1..2  
Defines the section: 1 = common assembly, 2 = RF assembly.

**Return values:**

<SNumber> string

**Example:** See [Chapter 11.1.1, "Performing General Task for Instrument Setup"](#), on page 191.

**Usage:** Query only

**Manual operation:** See ["Assembly"](#) on page 131

---

**:SYSTem:SOFTware:OPTion<dir>:DESignation?**

Queries the list of option descriptions.

**Suffix:**

<dir> 1..2  
Defines the section: 1 = hardware, 2 = software.

**Return values:**

<Designation> string

**Example:** See [Chapter 11.1.1, "Performing General Task for Instrument Setup"](#), on page 191.

**Usage:** Query only

**Manual operation:** See ["Hardware / Software/WinIQSIM"](#) on page 133

---

**:SYSTem:SOFTware:OPTion<dir>:EXPIration?**

Queries the list of option expiration informations.

**Suffix:**

<dir> 1..2  
Defines the section: 1 = hardware, 2 = software.

**Return values:**

<Expiration> string

**Example:** See [Chapter 11.1.1, "Performing General Task for Instrument Setup"](#), on page 191.

**Usage:** Query only

**Manual operation:** See ["Hardware / Software/WinIQSIM"](#) on page 133

---

**:SYSTem:SOFTware:OPTion<dir>:LICenses?**

Queries the list of option license counts.

**Suffix:**

<dir> 1..2  
Defines the section: 1 = hardware, 2 = software.

**Return values:**

<Licenses> string

**Example:** See [Chapter 11.1.1, "Performing General Task for Instrument Setup"](#), on page 191.

**Usage:** Query only

**Manual operation:** See "[Hardware / Software/WinIQSIM](#)" on page 133

---

**:SYSTem:SOFTware:OPTion<dir>:NAME?**

Queries the list of option names.

**Suffix:**

<dir> 1..2  
Defines the section: 1 = hardware, 2 = software.

**Return values:**

<Name> string

**Example:** See [Chapter 11.1.1, "Performing General Task for Instrument Setup"](#), on page 191.

**Usage:** Query only

**Manual operation:** See "[Hardware / Software/WinIQSIM](#)" on page 133

---

**:SYSTem:MMEMory:PATH:USER?**

Queries the user directory, that means the directory the instrument stores user files on.

**Return values:**

<PathUser> string

**Example:** SYSTem:MMEMory:PATH:USER?  
Response: "/var/sgs/"

**Usage:** Query only

---

**:SYSTem:OSYSstem?**

Queries the operating system of the instrument.

**Return values:**

<OperSystem> string

**Example:**           SYSTem:OSYSem?  
                  Response: "Linux"

**Usage:**            Query only

## 11.22 TEST Subsystem

The TEST system contains the commands for performing the routines as well as for direct manipulation of the hardware assemblies (:TEST:DIReCt).

The self tests return a "0" if the test is performed successfully, otherwise a value other than "0" is returned. None of the commands of this system have an \*RST value.

### NOTICE

#### Improper use can destroy the assembly

The respective hardware assembly responds directly to the :TEST:DIReCt command; any safety mechanisms are bypassed. The command is intended for servicing purposes and should be used only by the Rohde & Schwarz service personnel.

:TEST:ALL:START.....	278
:TEST:ALL:RESult?.....	278
:TEST:KEYBoard[:STATe].....	278

#### :TEST:ALL:START

Starts the selftest. Use the command :TEST:ALL:RESult? to query the result.

**Example:**           See [Chapter 11.1.1, "Performing General Task for Instrument Setup"](#), on page 191.

**Usage:**            Event

#### :TEST:ALL:RESult?

Queries the result of the performed selftest. Start the selftest with :TEST:ALL:START.

#### Return values:

<Result>            0 | 1 | RUNning | STOPped  
                      \*RST:       STOPped

**Example:**           See [Chapter 11.1.1, "Performing General Task for Instrument Setup"](#), on page 191.

**Usage:**            Query only

#### :TEST:KEYBoard[:STATe] <State>

Enable/disable keyboard and LED test state.

**Parameters:**  
 <State>                    0 | 1 | OFF | ON

## 11.23 UNIT Subsystem

The `UNIT` subsystem contains the commands specifying which units are valid if no unit is indicated in a command. These settings are valid for the entire instrument.

---

**:UNIT:ANGLE** <Angle>

Sets the default angle unit for remote control. Does not influence the manual control parameter units and the display.

**Parameters:**  
 <Angle>                    DEGRee | RADian  
 \*RST:                    RADian

**Example:**                    `UNIT:ANGL DEG`  
 sets DEG as a default unit for all commands which determine angle values.

---

**:UNIT:POWer** <Power>

Defines the default unit for power parameters. This setting affects the GUI, as well as all remote control commands that determine power values.

**Parameters:**  
 <Power>                    V | DBUV | DBM  
 \*RST:                    DBM

**Example:**                    `UNIT:POW V`  
 sets V as a default unit for all commands which determine power values.

## 11.24 List of R&S SGS Commands

<code>:CALibration:ALL[:MEASure]?</code> .....	205
<code>:CALibration:FREQuency:TEMPerature?</code> .....	207
<code>:CALibration:FREQuency[:MEASure]?</code> .....	206
<code>:CALibration:IQModulator:FULL?</code> .....	206
<code>:CALibration:IQModulator:LOCal?</code> .....	206
<code>:CALibration:IQModulator:TEMPerature?</code> .....	207
<code>:CALibration:LEVel:TEMPerature?</code> .....	207
<code>:CALibration:LEVel[:MEASure]?</code> .....	206
<code>:CALibration:OEXTension</code> .....	207
<code>:CALibration:ROSCillator:DATA:MODE</code> .....	207
<code>:CALibration:ROSCillator[:DATA]</code> .....	208

:CONNector:REFLo:OUTPut.....	208
:CONNector:TRIGger:OMODE.....	208
:DIAGnostic:POINt:CATalog?.....	209
:DIAGnostic[:MEASure]:POINt?.....	209
:EXTension:BUSY[:STATe]?.....	211
:EXTension:INSTruments:NAME?.....	210
:EXTension:INSTruments:REMote:CHANnel?.....	210
:EXTension:INSTruments:REMote:LAN:NAME?.....	211
:EXTension:INSTruments:REMote:SERial?.....	211
:EXTension:INSTruments:SCAN[:STATe].....	210
:EXTension:REMote:STATe?.....	210
:EXTension:SELect.....	212
:FFASt.....	221
:INITiate<hw>[:POWer]:CONTinuous.....	227
:LOCK?.....	203
:MEMory:HFRee?.....	219
:MMEMory:CATalog:LENGth?.....	216
:MMEMory:CATalog?.....	216
:MMEMory:CDIRectory.....	216
:MMEMory:COPI.....	217
:MMEMory:DATA.....	217
:MMEMory:DCATalog:LENGth?.....	218
:MMEMory:DCATalog?.....	218
:MMEMory:DELeTe.....	219
:MMEMory:LOAD:STATe.....	219
:MMEMory:MDIRectory.....	220
:MMEMory:MOVE.....	220
:MMEMory:MSIS.....	220
:MMEMory:RDIRectory.....	220
:MMEMory:STORe:STATe.....	221
:OUTPut:AFIXed:RANGe:LOWer?.....	222
:OUTPut:AFIXed:RANGe:UPPer?.....	222
:OUTPut:AMODE.....	222
:OUTPut[:STATe].....	223
:OUTPut[:STATe]:PON.....	223
:PFAST.....	221
:READ<ch>[:POWer]?.....	227
:SENSe<ch>:UNIT[:POWer].....	228
:SENSe<ch>[:POWer]:APERture:DEFault:STATe.....	228
:SENSe<ch>[:POWer]:APERture:TIME.....	229
:SENSe<ch>[:POWer]:CORRection:SPDeVice:LIST?.....	229
:SENSe<ch>[:POWer]:CORRection:SPDeVice:SELect.....	229
:SENSe<ch>[:POWer]:CORRection:SPDeVice:STATe.....	229
:SENSe<ch>[:POWer]:FILTer:LENGth:AUTO?.....	230
:SENSe<ch>[:POWer]:FILTer:LENGth[:USER].....	230
:SENSe<ch>[:POWer]:FILTer:NSRatio.....	231
:SENSe<ch>[:POWer]:FILTer:NSRatio:MTIME.....	231
:SENSe<ch>[:POWer]:FILTer:SONCe.....	231
:SENSe<ch>[:POWer]:FILTer:TYPE.....	232
:SENSe<ch>[:POWer]:FREQUency.....	232

:SENSe<ch>[:POWer]:LOGGing:STATe.....	233
:SENSe<ch>[:POWer]:OFFSet.....	233
:SENSe<ch>[:POWer]:OFFSet:STATe.....	233
:SENSe<ch>[:POWer]:SNUMber?	233
:SENSe<ch>[:POWer]:SOURce.....	234
:SENSe<ch>[:POWer]:STATus[:DEVice]?	234
:SENSe<ch>[:POWer]:SVERsion?	234
:SENSe<ch>[:POWer]:TYPE?	235
:SENSe<ch>[:POWer]:ZERO.....	235
:SLISt:ELEMent<ch>:MAPPing.....	226
:SLISt:SCAN[:STATe].....	226
:SLISt:SENSor:MAP.....	227
:SLISt[:LIST]?	226
:SOURce<hw>:PRESet.....	205
:STATus:OPERation:CONDition?	262
:STATus:OPERation:ENABle.....	262
:STATus:OPERation:NTRansition.....	263
:STATus:OPERation:PTRansition.....	263
:STATus:OPERation[:EVENT]	262
:STATus:PRESet.....	263
:STATus:QUESTionable:CONDition.....	263
:STATus:QUESTionable:ENABle.....	264
:STATus:QUESTionable:NTRansition.....	264
:STATus:QUESTionable:PTRansition.....	264
:STATus:QUESTionable[:EVENT]	264
:STATus:QUEEue[:NEXT]?	265
:SYSTem:COMMunicate:HISLip:RESourCe?	272
:SYSTem:COMMunicate:NETWork:IPADdress.....	269
:SYSTem:COMMunicate:NETWork:IPADdress:MODE.....	269
:SYSTem:COMMunicate:NETWork:MACaddress.....	270
:SYSTem:COMMunicate:NETWork:RESourCe?	271
:SYSTem:COMMunicate:NETWork:REStart.....	270
:SYSTem:COMMunicate:NETWork:STATus?	270
:SYSTem:COMMunicate:NETWork[:COMMON]:HOSTname.....	270
:SYSTem:COMMunicate:NETWork[:IPADdress]:GATeway.....	270
:SYSTem:COMMunicate:NETWork[:IPADdress]:SUBNet:MASK.....	271
:SYSTem:COMMunicate:PClexpress:RESourCe?	272
:SYSTem:COMMunicate:SERial:BAUD.....	271
:SYSTem:COMMunicate:SERial:PARity.....	271
:SYSTem:COMMunicate:SERial:RESourCe?	272
:SYSTem:COMMunicate:SERial:SBITs.....	272
:SYSTem:COMMunicate:SOCKet:PORT.....	273
:SYSTem:COMMunicate:SOCKet:RESourCe?	273
:SYSTem:COMMunicate:USB:RESourCe?	273
:SYSTem:EMODE.....	266
:SYSTem:ERRor:ALL?	266
:SYSTem:ERRor:CODE:ALL?	267
:SYSTem:ERRor:CODE[:NEXT]?	267
:SYSTem:ERRor:COUNt?	268
:SYSTem:ERRor[:NEXT]?	268

:SYSTem:FPReset.....	205
:SYSTem:HARDware:ASSEMBly<dir>:NAME?.....	275
:SYSTem:HARDware:ASSEMBly<dir>:PNUMBER?.....	275
:SYSTem:HARDware:ASSEMBly<dir>:REVISION?.....	275
:SYSTem:HARDware:ASSEMBly<dir>:SNUMBER?.....	276
:SYSTem:MMEMory:PATH:USER?.....	277
:SYSTem:OSYSem?.....	277
:SYSTem:PRESet.....	205
:SYSTem:PROTect<ch>[:STATE].....	274
:SYSTem:REBoot.....	273
:SYSTem:REStart.....	274
:SYSTem:SERRor?.....	268
:SYSTem:SHUTdown.....	274
:SYSTem:SOFTware:OPTion<dir>:DESignation?.....	276
:SYSTem:SOFTware:OPTion<dir>:EXPIration?.....	276
:SYSTem:SOFTware:OPTion<dir>:LICenses?.....	277
:SYSTem:SOFTware:OPTion<dir>:NAME?.....	277
:SYSTem:STARtup:COMPLete?.....	274
:SYSTem:VERSIon?.....	269
:TEST:ALL:RESult?.....	278
:TEST:ALL:STARt.....	278
:TEST:EXTension:CONNectiOn:RF?.....	212
:TEST:EXTension:CONNectiOn?.....	212
:TEST:KEYBord[:STATE].....	278
:UNIT:ANGLE.....	279
:UNIT:POWer.....	279
:UNLock.....	204
[:SOURce]:CORRection:CSET:CATalog?.....	238
[:SOURce]:CORRection:CSET:DELeTe.....	240
[:SOURce]:FREQuency:OFFSet.....	236
[:SOURce]:FREQuency[:CW FIXed].....	236
[:SOURce]:IQ:CREStfactor.....	247
[:SOURce]:IQ:IMPairment:IQRatio[:MAGNitude].....	246
[:SOURce]:IQ:IMPairment:LEAKage:I.....	246
[:SOURce]:IQ:IMPairment:LEAKage:Q.....	246
[:SOURce]:IQ:IMPairment:QUADrature[:ANGLE].....	247
[:SOURce]:IQ:IMPairment[:STATE].....	247
[:SOURce]:IQ:STATe.....	246
[:SOURce]:IQ:WBState.....	248
[:SOURce]:LOSCillator:SOURce.....	236
[:SOURce]:OPMode.....	235
[:SOURce]:PATH:COUNT?.....	237
[:SOURce]:PHASe.....	248
[:SOURce]:PHASe:REFerence.....	248
[:SOURce]:POWer:ALC:DSENSitivity.....	249
[:SOURce]:POWer:ALC:SONCe.....	249
[:SOURce]:POWer:ALC[:STATE].....	249
[:SOURce]:POWer:ATTenuation:RFOFF:MODE.....	250
[:SOURce]:POWer:ATTenuation:SOVer[:OFFSet].....	250
[:SOURce]:POWer:LIMit[:AMPLitude].....	252

[:SOURce]:POWer:LMODe.....	250
[:SOURce]:POWer:PEP?.....	252
[:SOURce]:POWer:POWer.....	250
[:SOURce]:POWer:RANGe:LOWer?.....	253
[:SOURce]:POWer:RANGe:UPPer?.....	253
[:SOURce]:POWer:SCHaracteristic.....	251
[:SOURce]:POWer[:LEVel][:IMMediate]:OFFSet.....	252
[:SOURce]:POWer[:LEVel][:IMMediate][:AMPLitude].....	251
[:SOURce]:ROSCillator:EXTernal:FREQuency.....	259
[:SOURce]:ROSCillator:EXTernal:SBANdwidth.....	261
[:SOURce]:ROSCillator:OUTPut:FREQuency.....	260
[:SOURce]:ROSCillator:SOURce.....	260
[:SOURce]:ROSCillator[:INTernal]:ADJJust:VALue.....	260
[:SOURce]:ROSCillator[:INTernal]:ADJJust[:STATe].....	260
[:SOURce<hw>]:CORRection:CSET:DATA:FREQuency.....	238
[:SOURce<hw>]:CORRection:CSET:DATA:FREQuency:POINts?.....	239
[:SOURce<hw>]:CORRection:CSET:DATA:POWer.....	239
[:SOURce<hw>]:CORRection:CSET:DATA:POWer:POINts?.....	239
[:SOURce<hw>]:CORRection:CSET:DATA[:SENSor<ch>]:POWer]:SONCe.....	240
[:SOURce<hw>]:CORRection:CSET[:SELeCt].....	244
[:SOURce<hw>]:CORRection:DEXChange:AFILe:CATALog?.....	240
[:SOURce<hw>]:CORRection:DEXChange:AFILe:EXTension.....	241
[:SOURce<hw>]:CORRection:DEXChange:AFILe:SELeCt.....	241
[:SOURce<hw>]:CORRection:DEXChange:AFILe:SEParator:COLumn.....	242
[:SOURce<hw>]:CORRection:DEXChange:AFILe:SEParator:DECimal.....	242
[:SOURce<hw>]:CORRection:DEXChange:EXECute.....	243
[:SOURce<hw>]:CORRection:DEXChange:MODE.....	243
[:SOURce<hw>]:CORRection:DEXChange:SELeCt.....	244
[:SOURce<hw>]:CORRection:VALue?.....	245
[:SOURce<hw>]:CORRection:ZERoing:STATe.....	245
[:SOURce<hw>]:CORRection[:STATe].....	245
[:SOURce<hw>]:PULM:DELay.....	255
[:SOURce<hw>]:PULM:DOUBle:DELay.....	256
[:SOURce<hw>]:PULM:DOUBle:WIDTh.....	256
[:SOURce<hw>]:PULM:MODE.....	256
[:SOURce<hw>]:PULM:PERiod.....	256
[:SOURce<hw>]:PULM:POLarity.....	257
[:SOURce<hw>]:PULM:SOURce.....	257
[:SOURce<hw>]:PULM:STATe.....	257
[:SOURce<hw>]:PULM:TRIGger:EXTernal:GATE:POLarity.....	258
[:SOURce<hw>]:PULM:TRIGger:EXTernal:IMPedance.....	258
[:SOURce<hw>]:PULM:TRIGger:EXTernal:SLOPe.....	258
[:SOURce<hw>]:PULM:TRIGger:MODE.....	258
[:SOURce<hw>]:PULM:WIDTh.....	259
*CLS.....	200
*ESE.....	200
*ESR?.....	200
*IDN?.....	200
*IST?.....	200
*OPC.....	201

*OPT?.....	201
*PRE.....	201
*PSC.....	201
*RCL.....	202
*RST.....	202
*SAV.....	202
*SRE.....	202
*STB?.....	202
*TRG.....	203
*TST?.....	203
*WAI.....	203

## 12 Maintenance

The instrument does not need periodic maintenance. Only cleaning the instrument is essential.

Follow the instructions in the service manual and the safety instructions when exchanging modules or ordering spare parts. The order number for spare parts is included in the service manual. The service manual includes further information particularly on troubleshooting, repair, exchange of modules (including battery exchange, adjustment of the OCXO oscillator) and alignment.

The address of our support center and a list of all Rohde & Schwarz service centers can be found at the beginning of this manual.

### 12.1 Cleaning

---

**⚠ WARNING****Risk of electric shock**

If moisture enters the casing, for example if you clean the instrument using a moist cloth, contact with the instrument can lead to electric shock. Before cleaning the instrument other than with a dry cloth, make sure that the instrument is switched off and disconnected from all power supplies.

---

**NOTICE****Instrument damage caused by cleaning agents**

Cleaning agents contain substances such as solvents (thinners, acetone, etc.), acids, bases, or other substances. Solvents can damage the front panel labeling, plastic parts, or screens, for example.

Never use cleaning agents to clean the outside of the instrument. Use a soft, dry, lint-free dust cloth instead.

---

**NOTICE****Risk of instrument damage due to obstructed fans**

If the instrument is operated in dusty areas, the fans become obstructed by dust or other particles over time. Check and clean the fans regularly to ensure that they always operate properly. If the instrument is run with obstructed fans for a longer period, the instrument overheats, which can disturb the operation and even cause damage.

1. Clean the outside of the instrument using a soft, dry, lint-free dust cloth.

2. Check and clean the fans regularly to ensure that they always operate properly.
3. Clean the touchscreen as follows:
  - a) Apply a small amount of standard screen cleaner to a soft cloth.
  - b) Wipe the screen gently with the moist, but not wet, cloth.
  - c) If necessary, remove any excess moisture with a dry, soft cloth.

## 12.2 Storing and Packing

The storage temperature range of the instrument is given in the data sheet. If the instrument is to be stored for a longer period of time, it must be protected against dust.

Repack the instrument as it was originally packed when transporting or shipping. The two protective foam plastic parts prevent the control elements and connectors from being damaged. The antistatic packing foil avoids any undesired electrostatic charging to occur.

If you do not use the original packaging, use a sturdy cardboard box of suitable size and provide for sufficient padding to prevent the instrument from slipping inside the package. Wrap antistatic packing foil around the instrument to protect it from electrostatic charging.

## 13 Error Messages and Troubleshooting

This chapter describes the error messages of the R&S SGS. The error messages are output in the "Info" line on the screen and entered in the error/event queue of the status reporting system.

A great variety of different messages such as status messages, error messages, warnings or information are displayed in the header field of the screen. Some error messages require that the error must be eliminated before correct instrument operation can be ensured. The "Info" window with a list of current messages and a detailed description of each message can be opened with the "Info" button (see also [Chapter 6.2.1, "Info Dialog"](#), on page 62).

### 13.1 Status Information

The status messages are displayed in the Info line of the R&S SGMA-GUI main panel. The status information gives the user an overview of the main operating states and settings of the instrument. The states are indicated for information only and do not necessitate any action by the user.

#### Status Information displayed in the Info line

##### **AttFixed**

Attenuator fixed mode is active.

The uninterrupted level settings are made in a fixed range without attenuator switching. The variation range is set automatically when this mode is activated. The range is displayed with the parameter "SGMA-GUI > Instrument Name > Level > Attenuator Fixed Range".

### 13.2 Error Messages

Messages indicate errors in the instrument. They are displayed in the info line in different colors depending on their importance and display duration. Errors (e.g. no calibration data) are displayed in red, information (e.g. file not found) and warnings in black. Warnings indicate less significant errors (e.g. the instrument operates outside specified data).

See also [Chapter 6.2.1, "Info Dialog"](#), on page 62 and [Chapter 6.2.2, "Understanding the Messages in the Info Bar"](#), on page 63.

#### 13.2.1 Volatile messages

Volatile messages report automatic settings in the instrument (e.g. switching off of incompatible types of modulation) or on illegal entries that are not accepted by the

instrument (e.g. range violations). They are displayed in the info line on a yellow background. They are displayed on top of status information or permanent messages.

Volatile messages do not normally demand user actions and disappear automatically after a brief period of time. They are stored in the history, however.

SCPI command: `:SYSTem:ERRor:ALL?` and `:SYSTem:ERRor[:NEXT]?`.

### 13.2.2 Permanent messages

Permanent messages are displayed if an error occurs that impairs further instrument operation, e.g. a hardware fault. The error signaled by a permanent message must be eliminated before correct instrument operation can be ensured.

The message is displayed until the error is eliminated. It covers the status display in the info line. After error elimination, the message automatically disappears and is also recorded in the history.

SCPI command: `:SYSTem:SERRor?`

## 13.3 SCPI-Error Messages

The SCPI error messages are the same in all SCPI instruments. Detailed information and an overview of all error messages as defined in SCPI standard can be found in the corresponding documentation.

The errors are assigned negative numbers. The error text being entered into the error/event queue or being displayed is printed in bold face on the left together with the error code. Below the error text, there is an explanation as to the respective error.

## 13.4 Device-Specific Error Messages

The following table contains all error messages specific for the instrument in alphabetical order, as well as an explanation of the error situation. The positive error codes mark the errors specific of the instrument.

The device-specific error messages set bit 3 in the ESR register.



The index provides a list of the error messages sorted according to their error codes.

---

Error Code	Error	Description	Remedy
180	Adjustment failed	Adjustment could not be executed	The adjustment data have to be generated first by an internal or external adjustment or to be loaded into the device.
182	Adjustment data missing	Adjustment data are missing.	The adjustment data have to be generated first by an internal or external adjustment or to be loaded into the instrument.
183	Adjustment data invalid	Adjustment data are invalid and must be restored.	The adjustment data have to be generated again by an internal or external adjustment or to be loaded into the instrument.
200	Cannot access hardware	The data transmission to a module was unsuccessful.	The module is not installed, not properly installed or missing.
201	Hardware revision out of date	A later version of certain parts of the instrument is necessary to execute the function selected.	The driver does not support the installed version of a module.
202	Cannot access the EEPROM	A error occurs when writing or reading a EEPROM.	The EEPROM might be defect and has to be replaced.
203	Invalid EEPROM data		
204	Driver initialization failed	Initialization of a driver fails when booting the instrument firmware.	The driver is not compatible with the hardware or software configuration of the instrument.
241	No current list	There is no list selected.	To execute the required operation, a list has to be selected in the related dialog. If no list is available, a new list must be created.
242	Unknown list type specified	The list type selected is not valid for the required operation.  For instance, the file extension for mapping files is *.map. It is not possible to enter another file extension when selecting a list.	Check the selected list type.
460	Cannot open file	The selected file can not be opened.	Check the path and file name.
461	Cannot write file	The file can not be written.	Check if the file is read-only.
462	Cannot read file	The file can not be read.	Check if the file contents are compatible with the file type.
463	Filename missing	The required operation cannot be executed because the file name is not specified.	A file name has to be entered when creating a new list.
464	Invalid filename extension	The file extension is not valid for the required operation.	Check the file extension.  For instance, the file extension for the mapping files is *.map. It is not possible to enter another file extension when storing a list.

Error Code	Error	Description	Remedy
465	File contains invalid data	The selected file contains data that is not valid for the file type.	Check the file extension. The file extension determines the data that is valid for this file type. If the file extension is changed the lists are no longer recognized and the data are therefore invalid.
468	Cannot find directory	Required folder cannot be found.	Check drive and path.
469	No files found	Folder is empty	

# Annex

## A Remote Control Basics

This chapter provides basic information on operating an instrument via remote control.

### A.1 Messages

The messages transferred on the data lines are divided into the following categories:

- **Interface messages**  
Interface messages are transmitted to the instrument on the data lines, with the attention line being active (LOW). They are used to communicate between the controller and the instrument. Interface messages can only be sent by instruments that have GPIB bus functionality. For details see the sections for the required interface.
- **Instrument messages**  
Instrument messages are employed in the same way for all interfaces, if not indicated otherwise in the description. Structure and syntax of the instrument messages are described in [Chapter A.3, "SCPI Command Structure"](#), on page 292. A detailed description of all messages available for the instrument is provided in the chapter "Remote Control Commands".  
There are different types of instrument messages, depending on the direction they are sent:
  - Commands
  - Instrument responses

#### Commands

Commands (program messages) are messages the controller sends to the instrument. They operate the instrument functions and request information. The commands are subdivided according to two criteria:

- According to the effect they have on the instrument:
  - **Setting commands** cause instrument settings such as a reset of the instrument or setting the frequency.
  - **Queries** cause data to be provided for remote control, e.g. for identification of the instrument or polling a parameter value. Queries are formed by directly appending a question mark to the command header.
- According to their definition in standards:
  - **Common commands**: their function and syntax are precisely defined in standard IEEE 488.2. They are employed identically on all instruments (if implemented). They refer to functions such as management of the standardized status registers, reset and self-test.
  - **Instrument control commands** refer to functions depending on the features of the instrument such as frequency settings. Many of these commands have also been standardized by the SCPI committee. These commands are marked as

"SCPI confirmed" in the command reference chapters. Commands without this SCPI label are device-specific; however, their syntax follows SCPI rules as permitted by the standard.

### Instrument responses

Instrument responses (response messages and service requests) are messages the instrument sends to the controller after a query. They can contain measurement results, instrument settings and information on the instrument status.

## A.2 LAN Interface Messages

In the LAN connection, the interface messages are called low-level control messages. These messages can be used to emulate interface messages of the GPIB bus.

Command	Long term	Effect on the instrument
&ABO	Abort	Aborts processing of the commands just received.
&DCL	Device Clear	Aborts processing of the commands just received and sets the command processing software to a defined initial state. Does not change the instrument setting.
&GTL	Go to Local	Transition to the "local" state (manual control). (The instrument automatically returns to remote state when a remote command is sent UNLESS &NREN was sent before.)
&GTR	Go to Remote	Enables automatic transition from local state to remote state by a subsequent remote command (after &NREN was sent).
&GET	Group Execute Trigger	Triggers a previously active instrument function (e.g. a sweep). The effect of the command is the same as with that of a pulse at the external trigger signal input.
&LLO	Local Lockout	Disables transition from remote control to manual control by means of the front panel keys.
&NREN	Not Remote Enable	Disables automatic transition from local state to remote state by a subsequent remote command. (To re-activate automatic transition use &GTR.)
&POL	Serial Poll	Starts a serial poll.

## A.3 SCPI Command Structure

SCPI commands consist of a header and, in most cases, one or more parameters. The header and the parameters are separated by a "white space" (ASCII code 0 to 9, 11 to 32 decimal, e.g. blank). The headers may consist of several mnemonics (keywords). Queries are formed by appending a question mark directly to the header.

The commands can be either device-specific or device-independent (common commands). Common and device-specific commands differ in their syntax.

### A.3.1 Syntax for Common Commands

Common (= device-independent) commands consist of a header preceded by an asterisk (\*), and possibly one or more parameters.

**Table A-1: Examples of common commands**

*RST	RESET	Resets the instrument.
*ESE	EVENT STATUS ENABLE	Sets the bits of the event status enable registers.
*ESR?	EVENT STATUS QUERY	Queries the contents of the event status register.
*IDN?	IDENTIFICATION QUERY	Queries the instrument identification string.

### A.3.2 Syntax for Device-Specific Commands



Not all commands used in the following examples are necessarily implemented in the instrument. For demonstration purposes only, assume the existence of the following commands for this section:

- DISPLAY[:WINDow<1...4>]:MAXimize <Boolean>
- FORMat:READings:DATA <type>[,<length>]
- HCOpy:DEvice:COLor <Boolean>
- HCOpy:DEvice:CMAP:COLor:RGB <red>,<green>,<blue>
- HCOpy[:IMMediate]
- HCOpy:ITEM:ALL
- HCOpy:ITEM:LABel <string>
- HCOpy:PAGE:DIMensions:QUADrant [<N>]
- HCOpy:PAGE:ORientation LANDscape | PORTrait
- HCOpy:PAGE:SCALE <numeric value>
- MMEMory:COpy <file\_source>,<file\_destination>
- SENSE:BANDwidth|BWIDth[:RESolution] <numeric\_value>
- SENSE:FREQuency:STOP <numeric value>
- SENSE:LIST:FREQuency <numeric\_value>{,<numeric\_value>}

- [Long and short form](#)..... 294
- [Numeric Suffixes](#)..... 294
- [Optional Mnemonics](#)..... 294

### A.3.2.1 Long and short form

The mnemonics feature a long form and a short form. The short form is marked by upper case letters, the long form corresponds to the complete word. Either the short form or the long form can be entered; other abbreviations are not permitted.

**Example:**

HCOPY:DEVIce:COLor ON is equivalent to HCOP:DEV:COL ON.



#### Case-insensitivity

Upper case and lower case notation only serves to distinguish the two forms in the manual, the instrument itself is case-insensitive.

---

### A.3.2.2 Numeric Suffixes

If a command can be applied to multiple instances of an object, e.g. specific channels or sources, the required instances can be specified by a suffix added to the command. Numeric suffixes are indicated by angular brackets (<1...4>, <n>, <i>) and are replaced by a single value in the command. Entries without a suffix are interpreted as having the suffix 1.

**Example:**

Definition: HCOpy:PAGE:DIMenSions:QUADrant [<N>]

Command: HCOP:PAGE:DIM:QUAD2

This command refers to the quadrant 2.



#### Different numbering in remote control

For remote control, the suffix may differ from the number of the corresponding selection used in manual operation. SCPI prescribes that suffix counting starts with 1. Suffix 1 is the default state and used when no specific suffix is specified.

Some standards define a fixed numbering, starting with 0. If the numbering differs in manual operation and remote control, it is indicated for the corresponding command.

---

### A.3.2.3 Optional Mnemonics

Some command systems permit certain mnemonics to be inserted into the header or omitted. These mnemonics are marked by square brackets in the description. The instrument must recognize the long command to comply with the SCPI standard. Some commands are considerably shortened by these optional mnemonics.

**Example:**

Definition: HCOpy[:IMMediate]

Command: HCOP:IMM is equivalent to HCOP



### Optional mnemonics with numeric suffixes

Do not omit an optional mnemonic if it includes a numeric suffix that is relevant for the effect of the command.

#### Example:

Definition: `DISPlay[:WINDow<1...4>]:MAXimize <Boolean>`

Command: `DISP:MAX ON` refers to window 1.

In order to refer to a window other than 1, you must include the optional `WINDow` parameter with the suffix for the required window.

`DISP:WIND2:MAX ON` refers to window 2.

## A.3.3 SCPI Parameters

Many commands are supplemented by a parameter or a list of parameters. The parameters must be separated from the header by a "white space" (ASCII code 0 to 9, 11 to 32 decimal, e.g. blank).

The parameters required for each command and the allowed range of values are specified in the command description.

Allowed parameters are:

- [Numeric Values](#)..... 295
- [Special Numeric Values](#)..... 296
- [Boolean Parameters](#)..... 297
- [Text Parameters](#)..... 297
- [Character Strings](#)..... 297
- [Block Data](#)..... 297

### A.3.3.1 Numeric Values

Numeric values can be entered in any form, i.e. with sign, decimal point and exponent. Values exceeding the resolution of the instrument are rounded up or down. The mantissa may comprise up to 255 characters, the exponent must lie inside the value range -32000 to 32000. The exponent is introduced by an "E" or "e". Entry of the exponent alone is not allowed.

#### Example:

`SENS:FREQ:STOP 1500000 = SENS:FREQ:STOP 1.5E6`

#### Units

For physical quantities, the unit can be entered. If the unit is missing, the basic unit is used. Allowed unit prefixes are:

- G (giga)
- MA (mega), MOHM, MHZ
- K (kilo)

- M (milli)
- U (micro)
- N (nano)

**Example:**

```
SENSe:FREQ:STOP 1.5GHz = SENSe:FREQ:STOP 1.5E9
```

Some settings allow relative values to be stated in percent. According to SCPI, this unit is represented by the `PCT` string.

**Example:**

```
HCOP:PAGE:SCAL 90PCT
```

### A.3.3.2 Special Numeric Values

The following mnemonics are special numeric values. In the response to a query, the numeric value is provided.

- **MIN and MAX:** denote the minimum and maximum value.
- **DEF:** denotes a preset value which has been stored in the EPROM. This value conforms to the default setting, as it is called by the `*RST` command.
- **UP and DOWN:** increases or reduces the numeric value by one step. The step width can be specified via an allocated step command for each parameter which can be set via `UP` and `DOWN`.
- **INF and NINF:** INFinity and negative INFinity (NINF) represent the numeric values  $9.9E37$  or  $-9.9E37$ , respectively. `INF` and `NINF` are only sent as instrument responses.
- **NAN:** Not A Number (NAN) represents the value  $9.91E37$ . `NAN` is only sent as a instrument response. This value is not defined. Possible causes are the division of zero by zero, the subtraction of infinite from infinite and the representation of missing values.

**Example:**

Setting command: `SENSe:LIST:FREQ MAXimum`

Query: `SENS:LIST:FREQ?`

Response: `3.5E9`



#### Queries for special numeric values

The numeric values associated to `MAXimum`/`MINimum`/`DEFault` can be queried by adding the corresponding mnemonic after the quotation mark.

Example: `SENSe:LIST:FREQ? MAXimum`

Returns the maximum numeric value as a result.

### A.3.3.3 Boolean Parameters

Boolean parameters represent two states. The "ON" state (logically true) is represented by "ON" or a numeric value 1. The "OFF" state (logically untrue) is represented by "OFF" or the numeric value 0. The numeric values are provided as the response for a query.

**Example:**

Setting command: `HCOPY:DEV:COL ON`

Query: `HCOPY:DEV:COL?`

Response: 1

### A.3.3.4 Text Parameters

Text parameters observe the syntactic rules for mnemonics, i.e. they can be entered using a short or long form. Like any parameter, they have to be separated from the header by a white space. In the response to a query, the short form of the text is provided.

**Example:**

Setting command: `HCOPY:PAGE:ORIENTATION LANDscape`

Query: `HCOPY:PAGE:ORI?`

Response: LAND

### A.3.3.5 Character Strings

Strings must always be entered in quotation marks (' or ").

**Example:**

`HCOPY:ITEM:LABEL "Test1"`

`HCOPY:ITEM:LABEL 'Test1'`

### A.3.3.6 Block Data

Block data is a format which is suitable for the transmission of large amounts of data. For example, a command using a block data parameter has the following structure:

```
FORMat:READings:DATA #45168xxxxxxxx
```

The ASCII character # introduces the data block. The next number indicates how many of the following digits describe the length of the data block. In the example the 4 following digits indicate the length to be 5168 bytes. The data bytes follow. During the transmission of these data bytes all end or other control signs are ignored until all bytes are transmitted.

#0 specifies a data block of indefinite length. The use of the indefinite format requires a `NL^END` message to terminate the data block. This format is useful when the length of

the transmission is not known or if speed or other considerations prevent segmentation of the data into blocks of definite length.

### A.3.4 Overview of Syntax Elements

The following tables provide an overview of the syntax elements and special characters.

**Table A-2: Syntax elements**

:	The colon separates the mnemonics of a command.
;	The semicolon separates two commands of a command line. It does not alter the path.
,	The comma separates several parameters of a command.
?	The question mark forms a query.
*	The asterisk marks a common command.
' '	Quotation marks introduce a string and terminate it (both single and double quotation marks are possible).
#	The hash symbol introduces binary, octal, hexadecimal and block data. <ul style="list-style-type: none"> <li>• Binary: #B10110</li> <li>• Octal: #O7612</li> <li>• Hexa: #HF3A7</li> <li>• Block: #21312</li> </ul>
	A "white space" (ASCII-Code 0 to 9, 11 to 32 decimal, e.g. blank) separates the header from the parameters.

Table A-3: Special characters

	<p><b>Parameters</b></p> <p>A vertical stroke in parameter definitions indicates alternative possibilities in the sense of "or". The effect of the command differs, depending on which parameter is used.</p> <p>Example:</p> <p>Definition: <code>HCOPY:PAGE:ORIENTATION LANDscape   PORtrait</code></p> <p>Command <code>HCOPY:PAGE:ORI LAND</code> specifies landscape orientation</p> <p>Command <code>HCOPY:PAGE:ORI PORT</code> specifies portrait orientation</p> <p><b>Mnemonics</b></p> <p>A selection of mnemonics with an identical effect exists for several commands. These mnemonics are indicated in the same line; they are separated by a vertical stroke. Only one of these mnemonics needs to be included in the header of the command. The effect of the command is independent of which of the mnemonics is used.</p> <p>Example:</p> <p>Definition: <code>SENSE:BANDwidth BWIDTH[:RESolution] &lt;numeric_value&gt;</code></p> <p>The two following commands with identical meaning can be created:</p> <p><code>SENS:BAND:RES 1</code></p> <p><code>SENS:BWID:RES 1</code></p>
[]	<p>Mnemonics in square brackets are optional and may be inserted into the header or omitted.</p> <p>Example: <code>HCOPY[:IMMEDIATE]</code></p> <p><code>HCOPY:IMM</code> is equivalent to <code>HCOPY</code></p>
{ }	<p>Parameters in curly brackets are optional and can be inserted once or several times, or omitted.</p> <p>Example: <code>SENSE:LIST:FREQUENCY &lt;numeric_value&gt;{,&lt;numeric_value&gt;}</code></p> <p>The following are valid commands:</p> <p><code>SENS:LIST:FREQ 10</code></p> <p><code>SENS:LIST:FREQ 10,20</code></p> <p><code>SENS:LIST:FREQ 10,20,30,40</code></p>

### A.3.5 Structure of a Command Line

A command line may consist of one or several commands. It is terminated by one of the following:

- <New Line>
- <New Line> with EOI
- EOI together with the last data byte

Several commands in a command line must be separated by a semicolon ";".

**Example:**

```
MMEM:COPY "Test1","MeasurementXY";:HCOPY:ITEM ALL
```

This command line contains two commands. The first command belongs to the MMEM system, the second command belongs to the HCOPY system. If the next command belongs to a different command system, the semicolon is followed by a colon.

**Example:**

```
HCOP:ITEM ALL;;HCOP:IMM
```

This command line contains two commands. Both commands are part of the HCOP command system, i.e. they have one level in common.

If the successive commands belong to the same system, having one or several levels in common, the command line can be abbreviated. When abbreviating the command line, the second command begins with the level below HCOP. The colon after the semi-colon is omitted. The abbreviated form of the command line reads as follows:

```
HCOP:ITEM ALL;IMM
```

**Example:**

```
HCOP:ITEM ALL
```

```
HCOP:IMM
```

A new command line always begins with the complete path.

### A.3.6 Responses to Queries

A query is defined for each setting command unless explicitly specified otherwise. It is formed by adding a question mark to the associated setting command. According to SCPI, the responses to queries are partly subject to stricter rules than in standard IEEE 488.2.

- The requested parameter is transmitted without a header.  
**Example:** HCOP:PAGE:ORI?, **Response:** LAND
- Maximum values, minimum values and all other quantities that are requested via a special text parameter are returned as numeric values.  
**Example:** SENSE:FREQUENCY:STOP? MAX, **Response:** 3.5E9
- Numeric values are output without a unit. Physical quantities are referred to the basic units or to the units set using the Unit command. The response 3.5E9 in the previous example stands for 3.5 GHz.
- Truth values (Boolean values) are returned as 0 (for OFF) and 1 (for ON).  
**Example:**  
Setting command: HCOPI:DEV:COL ON  
Query: HCOPI:DEV:COL?  
Response: 1
- Text (character data) is returned in a short form.  
**Example:**  
Setting command: HCOPI:PAGE:ORIENTATION LANDscape  
Query: HCOP:PAGE:ORI?  
Response: LAND
- Invalid numerical results  
In some cases, particularly when a result consists of multiple numeric values, invalid values are returned as 9.91E37 (not a number).

## A.4 Command Sequence and Synchronization

IEEE 488.2 defines a distinction between overlapped and sequential commands:

- A sequential command is one which finishes executing before the next command starts executing. Commands that are processed quickly are usually implemented as sequential commands. Sequential commands are not implemented in the instrument, however the execution time of most commands is so short that they act as sequential commands when sent in different command lines.
- An overlapping command is one which does not automatically finish executing before the next command starts executing. Usually, overlapping commands take longer to process and allow the program to do other tasks while being executed. If overlapping commands do have to be executed in a defined order, e.g. in order to avoid wrong measurement results, they must be serviced sequentially. This is called synchronization between the controller and the instrument.

Setting commands within one command line, even though they may be implemented as sequential commands, are not necessarily serviced in the order in which they have been received. In order to make sure that commands are actually carried out in a certain order, each command must be sent in a separate command line.



As a general rule, send commands and queries in different program messages.

### A.4.1 Preventing Overlapping Execution

To prevent an overlapping execution of commands, one of the commands `*OPC`, `*OPC?` or `*WAI` can be used. All three commands cause a certain action only to be carried out after the hardware has been set. The controller can be forced to wait for the corresponding action to occur.

**Table A-4: Synchronization using `*OPC`, `*OPC?` and `*WAI`**

Com-mand	Action	Programming the controller
<code>*OPC</code>	Sets the Operation Complete bit in the ESR after all previous commands have been executed.	<ul style="list-style-type: none"> <li>• Setting bit 0 in the ESE</li> <li>• Setting bit 5 in the SRE</li> <li>• Waiting for service request (SRQ)</li> </ul>
<code>*OPC?</code>	Stops command processing until 1 is returned. This occurs when all pending operations are completed.	Send <code>*OPC?</code> directly after the command whose processing must be terminated before other commands can be executed.
<code>*WAI</code>	Stops further command processing until all commands sent before <code>*WAI</code> have been executed.	Send <code>*WAI</code> directly after the command whose processing must be terminated before other commands are executed.

Command synchronization using `*WAI` or `*OPC?` is a good choice if the overlapped command takes only little time to process. The two synchronization commands simply block overlapped execution of the command. Append the synchronization command to the overlapping command, for example:

SINGLE; \*OPC?

For time consuming overlapped commands, you can allow the controller or the instrument to do other useful work while waiting for command execution. Use one of the following methods:

#### **\*OPC with a service request**

1. Set the OPC mask bit (bit no. 0) in the ESE: \*ESE 1
2. Set bit no. 5 in the SRE: \*SRE 32 to enable ESB service request.
3. Send the overlapped command with \*OPC .
4. Wait for a service request.

The service request indicates that the overlapped command has finished.

#### **\*OPC? with a service request**

1. Set bit no. 4 in the SRE: \*SRE 16 to enable MAV service request.
2. Send the overlapped command with \*OPC?.
3. Wait for a service request.

The service request indicates that the overlapped command has finished.

#### **Event status register (ESE)**

1. Set the OPC mask bit (bit no. 0) in the ESE: \*ESE 1
2. Send the overlapped command without \*OPC, \*OPC? or \*WAI.
3. Poll the operation complete state periodically (with a timer) using the sequence: \*OPC; \*ESR?

A return value (LSB) of 1 indicates that the overlapped command has finished.

## **A.5 Status Reporting System**

The status reporting system stores all information on the current operating state of the instrument, and on errors which have occurred. This information is stored in the status registers and in the error queue.

You can query both with the commands of the [STATus Subsystem](#).

### **A.5.1 Hierarchy of the Status Registers**

The [Figure A-1](#) shows the hierarchical structure of information in the status registers (ascending from left to right).

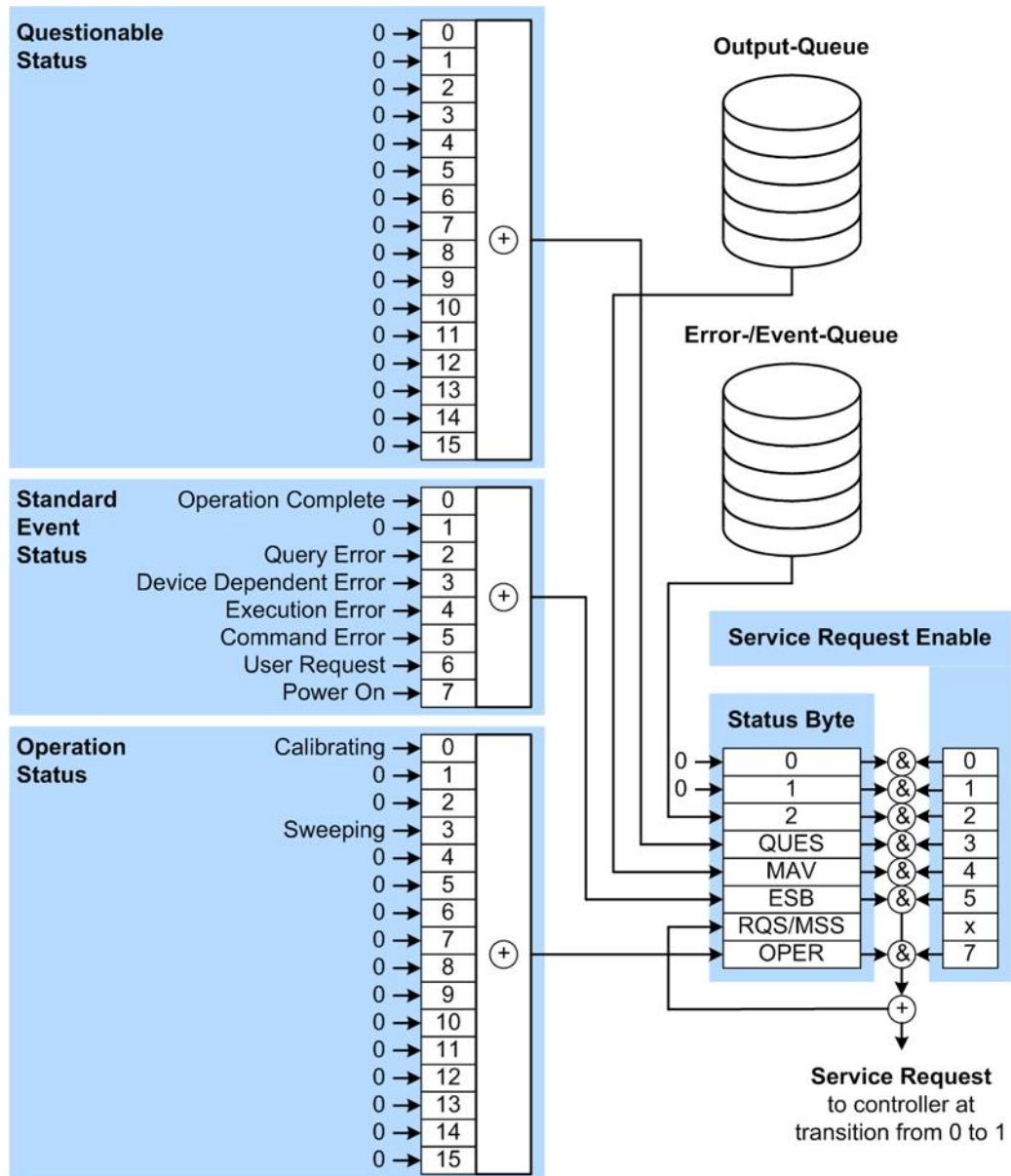

Figure A-1: Graphical overview of the status registers hierarchy

- OPER = Operation Status Summary Bit
- RQS/MSS = Service Request Generation
- ESB = Standard Event Status Summary Bit
- MAV = Message Available in Output Queue
- QUES = Questionable Status Summary Bit
- 2 = Error- /Event-Queue
- 1, 0 = not used

**Note:** This legend explains the abbreviations to the Status Byte Register.

The R&S SGS uses the following status registers:

- **Status Byte (STB)** and **Service Request Enable (SRE)**, see [Chapter A.5.3, "Status Byte \(STB\) and Service Request Enable Register \(SRE\)"](#), on page 306.

- **Standard Event Status**, i.e. the Event status Register (ESR) and the Event Status Enable (ESE), see [Chapter A.5.4, "Event Status Register \(ESR\) and Event Status Enable Register \(ESE\)"](#), on page 307.
- **Questionable Status and Operation Status**, the (SCPI status registers, see [Chapter A.5.2, "Structure of a SCPI Status Register"](#), on page 304, [Chapter A.5.5, "Questionable Status Register \(STATus:QUEStionable\)"](#), on page 307 and [Chapter A.5.6, "Operation Status Register \(STATus:OPERation\)"](#), on page 308.
- **Output-Queue**  
The output queue contains the messages the instrument returns to the controller. It is not part of the status reporting system but determines the value of the MAV bit in the STB and thus is represented in the overview.
- **Error- /Event-Queue**  
The error-/event-queue contains all errors and events that have occurred in the past. When reading the queue, the instrument starts with the first occurred error/ event.

All status registers have the same internal structure.



**SRE, ESE**

The service request enable register SRE can be used as ENABLE part of the STB if the STB is structured according to SCPI. By analogy, the ESE can be used as the ENABLE part of the ESR.

**A.5.2 Structure of a SCPI Status Register**

Each standard SCPI register consists of 5 parts. Each part has a width of 16 bits and has different functions. The individual bits are independent of each other, i.e. each hardware status is assigned a bit number which is valid for all five parts. Bit 15 (the most significant bit) is set to zero for all parts. Thus the contents of the register parts can be processed by the controller as positive integers.

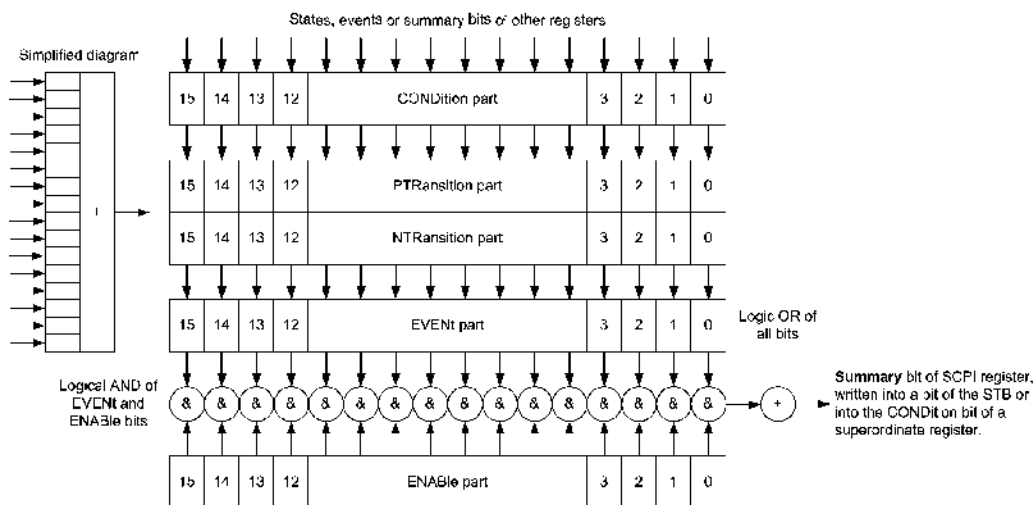

Figure A-2: The status-register model

### Description of the five status register parts

The five parts of a SCPI register have different properties and functions:

- **CONDition**

The `CONDition` part is written into directly by the hardware or the sum bit of the next lower register. Its contents reflect the current instrument status. This register part can only be read, but not written into or cleared. Its contents are not affected by reading.

- **PTRansition / NTRansition**

The two transition register parts define which state transition of the `CONDition` part (none, 0 to 1, 1 to 0 or both) is stored in the `EVENT` part.

The **Positive-TRansition** part acts as a transition filter. When a bit of the `CONDition` part is changed from 0 to 1, the associated `PTR` bit decides whether the `EVENT` bit is set to 1.

- `PTR` bit =1: the `EVENT` bit is set.
- `PTR` bit =0: the `EVENT` bit is not set.

This part can be written into and read as required. Its contents are not affected by reading.

The **Negative-TRansition** part also acts as a transition filter. When a bit of the `CONDition` part is changed from 1 to 0, the associated `NTR` bit decides whether the `EVENT` bit is set to 1.

- `NTR` bit =1: the `EVENT` bit is set.
- `NTR` bit =0: the `EVENT` bit is not set.

This part can be written into and read as required. Its contents are not affected by reading.

- **EVENT**

The `EVENT` part indicates whether an event has occurred since the last reading, it is the "memory" of the condition part. It only indicates events passed on by the transition filters. It is permanently updated by the instrument. This part can only be read by the user. Reading the register clears it. This part is often equated with the entire register.

- **ENABLE**

The `ENABLE` part determines whether the associated `EVENT` bit contributes to the sum bit (see below). Each bit of the `EVENT` part is "ANDed" with the associated `ENABLE` bit (symbol '&'). The results of all logical operations of this part are passed on to the sum bit via an "OR" function (symbol '+').

`ENABLE` bit = 0: the associated `EVENT` bit does not contribute to the sum bit

`ENABLE` bit = 1: if the associated `EVENT` bit is "1", the sum bit is set to "1" as well.

This part can be written into and read by the user as required. Its contents are not affected by reading.

### Sum bit

The sum bit is obtained from the `EVENT` and `ENABLE` part for each register. The result is then entered into a bit of the `CONDition` part of the higher-order register.

The instrument automatically generates the sum bit for each register. Thus an event can lead to a service request throughout all levels of the hierarchy.

### A.5.3 Status Byte (STB) and Service Request Enable Register (SRE)

The `STatus Byte` (STB) is already defined in IEEE 488.2. It provides a rough overview of the instrument status by collecting the pieces of information of the lower registers. A special feature is that bit 6 acts as the sum bit of the remaining bits of the status byte.

The STB is read using the command `*STB?` or a serial poll.

The `STatus Byte` (STB) is linked to the `Service Request Enable` (SRE) register. Each bit of the STB is assigned a bit in the SRE. Bit 6 of the SRE is ignored. If a bit is set in the SRE and the associated bit in the STB changes from 0 to 1, a service request (SRQ) is generated. The SRE can be set using the command `*SRE` and read using the command `*SRE?`.

**Table A-5: Meaning of the bits used in the status byte**

Bit No.	Meaning
0...1	Not used
2	Error Queue not empty The bit is set when an entry is made in the error queue. If this bit is enabled by the SRE, each entry of the error queue generates a service request. Thus an error can be recognized and specified in greater detail by polling the error queue. The poll provides an informative error message. This procedure is to be recommended since it considerably reduces the problems involved with remote control.
3	QUESTionable status register summary bit The bit is set if an <code>EVENT</code> bit is set in the <code>QUESTionable</code> status register and the associated <code>ENABLE</code> bit is set to 1. A set bit indicates a questionable instrument status, which can be specified in greater detail by querying the <code>STATus:QUESTionable</code> status register.
4	MAV bit (message available) The bit is set if a message is available in the output queue which can be read. This bit can be used to enable data to be automatically read from the instrument to the controller.
5	ESB bit Sum bit of the event status register. It is set if one of the bits in the event status register is set and enabled in the event status enable register. Setting of this bit indicates a serious error which can be specified in greater detail by polling the event status register.
6	MSS bit (master status summary bit) The bit is set if the instrument triggers a service request. This is the case if one of the other bits of this registers is set together with its mask bit in the service request enable register SRE.
7	<code>STATus:OPERation</code> status register summary bit The bit is set if an <code>EVENT</code> bit is set in the <code>OPERation</code> status register and the associated <code>ENABLE</code> bit is set to 1. A set bit indicates that the instrument is just performing an action. The type of action can be determined by querying the <code>STATus:OPERation</code> status register.

### A.5.4 Event Status Register (ESR) and Event Status Enable Register (ESE)

The ESR is defined in IEEE 488.2. It can be compared with the `EVENT` part of a SCPI register. The event status register can be read out using command `*ESR?`.

The ESE corresponds to the `ENABLE` part of a SCPI register. If a bit is set in the ESE and the associated bit in the ESR changes from 0 to 1, the ESB bit in the STB is set. The ESE register can be set using the command `*ESE` and read using the command `*ESE?`.

**Table A-6: Meaning of the bits used in the event status register**

Bit No.	Meaning
0	Operation Complete This bit is set on receipt of the command <code>*OPC</code> exactly when all previous commands have been executed.
1	Not used
2	Query Error This bit is set if either the controller wants to read data from the instrument without having sent a query, or if it does not fetch requested data and sends new instructions to the instrument instead. The cause is often a query which is faulty and hence cannot be executed.
3	Device-dependent Error This bit is set if a device-dependent error occurs. An error message with a number between -300 and -399 or a positive error number, which denotes the error in greater detail, is entered into the error queue.
4	Execution Error This bit is set if a received command is syntactically correct but cannot be performed for other reasons. An error message with a number between -200 and -300, which denotes the error in greater detail, is entered into the error queue.
5	Command Error This bit is set if a command is received, which is undefined or syntactically incorrect. An error message with a number between -100 and -200, which denotes the error in greater detail, is entered into the error queue.
6	User Request This bit is set when the instrument is switched over to manual control.
7	Power On (supply voltage on) This bit is set on switching on the instrument.

### A.5.5 Questionable Status Register (STATus:QUESTIONable)

This register contains information on questionable instrument states. Such states may occur when the instrument is not operated in compliance with its specifications.

To read the register, use the query commands `STAT:QUEST:COND?` or `STAT:QUEST[:EVEN]?`.

*Table A-7: Meaning of the bits used in the questionable status register*

Bit No.	Meaning
0–15	Not used

## A.5.6 Operation Status Register (STATus:OPERation)

This condition part contains information on the actions currently being performed by the instrument, while the event part contains information on the actions performed by the instrument since the last readout of the register.

To read the register, use the query commands `STAT:OPER:COND?` or `STAT:OPER[:EVEN]?`.

*Table A-8: Meaning of the bits used in the operation status register*

Bit No.	Meaning
0	Calibrating The bit is set during the calibration phase.
1–2	Not used
3	Sweeping This bit is set during a sweep in automatic or single mode.
4–15	Not used

## A.5.7 Application of the Status Reporting System

The purpose of the status reporting system is to monitor the status of one or several devices in a measuring system. To do this and react appropriately, the controller must receive and evaluate the information of all devices. The following standard methods are used:

- **Service request** (SRQ) initiated by the instrument
- **Serial poll** of all devices in the bus system, initiated by the controller to find out who sent an SRQ and why
- Query of a **specific instrument status** by commands
- Query of the **error queue**

### A.5.7.1 Service Request

Under certain circumstances, the instrument can send a service request (SRQ) to the controller. Usually this service request initiates an interrupt at the controller, to which the control program can react appropriately. An SRQ is always initiated if one or several of bits 2, 4 or 5 of the status byte are set and enabled in the SRE. Each of these bits combines the information of the error queue or the output buffer. To use the possibilities of the service request effectively, all bits should be set to "1" in the enable registers SRE and ESE.

**Example:**

Use command `*OPC` to generate an SRQ .

`*ESE 1` - set bit 0 of ESE (Operation Complete)

`*SRE 32` - set bit 5 of SRE (ESB).

After its settings have been completed, the instrument generates an SRQ.

The SRQ is the only possibility for the instrument to become active on its own. Each controller program should set the instrument such that a service request is initiated in the case of malfunction. The program should react appropriately to the service request.

### A.5.7.2 Serial Poll

In a serial poll, just as with command `*STB`, the status byte of an instrument is queried. However, the query is realized via interface messages and is thus clearly faster.

The serial poll method is defined in IEEE 488.1 and used to be the only standard possibility for different instruments to poll the status byte. The method also works for instruments which do not adhere to SCPI or IEEE 488.2.

The serial poll is mainly used to obtain a fast overview of the state of several instruments connected to the controller.

### A.5.7.3 Query of an instrument status

Each part of any status register can be read using queries. There are two types of commands:

- The common commands `*ESR?`, `*IDN?`, `*IST?`, `*STB?` query the higher-level registers.
- The commands of the `STATus` system query the SCPI registers (`STATus:QUEStionable...`)

The returned value is always a decimal number that represents the bit pattern of the queried register. This number is evaluated by the controller program.

Queries are usually used after an SRQ in order to obtain more detailed information on the cause of the SRQ.

### A.5.7.4 Error Queue

Each error state in the instrument leads to an entry in the error queue. The entries of the error queue are detailed plain text error messages that can be looked up in the Error Log or queried via remote control using `SYSTem:ERRor[:NEXT]?`. Each call of `SYSTem:ERRor[:NEXT]?` provides one entry from the error queue. If no error messages are stored there any more, the instrument responds with 0, "No error".

The error queue should be queried after every SRQ in the controller program as the entries describe the cause of an error more precisely than the status registers. Especially in the test phase of a controller program the error queue should be queried regu-

larly since faulty commands from the controller to the instrument are recorded there as well.

### A.5.8 Reset Values of the Status Reporting System

The following table contains the different commands and events causing the status reporting system to be reset. None of the commands, except of \*RST and SYSTem:PRESet affect the functional instrument settings. In particular, DCL does not change the instrument settings.

**Table A-9: Resetting the status reporting system**

Event	Switching on supply voltage Power-On-Status-Clear		DCL, SDC  (Device Clear, Selected Device Clear)	*RST or SYSTem: PRESet	STATus: PRESet	*CLS
	0	1				
Clear STB, ESR	-	Yes	-	-	-	Yes
Clear SRE, ESE	-	Yes	-	-	-	-
Clear PPE	-	Yes	-	-	-	-
Clear error queue	Yes	Yes	-	-	-	Yes
Clear output buffer	Yes	Yes	Yes	1)	1)	1)
Clear command processing and input buffer	Yes	Yes	Yes	-	-	-

1) The first command in a command line that immediately follows a <PROGRAM MESSAGE TERMINATOR> clears the output buffer.

## A.6 General Programming Recommendations

### Initial instrument status before changing settings

Manual operation is designed for maximum possible operating convenience. In contrast, the priority of remote control is the "predictability" of the instrument status. Thus, when a command attempts to define incompatible settings, the command is ignored and the instrument status remains unchanged, i.e. other settings are not automatically adapted. Therefore, control programs should always define an initial instrument status (e.g. using the \*RST command) and then implement the required settings.

### Command sequence

As a general rule, send commands and queries in different program messages. Otherwise, the result of the query may vary depending on which operation is performed first (see also Preventing Overlapping Execution).

**Reacting to malfunctions**

The service request is the only possibility for the instrument to become active on its own. Each controller program should instruct the instrument to initiate a service request in case of malfunction. The program should react appropriately to the service request.

**Error queues**

The error queue should be queried after every service request in the controller program as the entries describe the cause of an error more precisely than the status registers. Especially in the test phase of a controller program the error queue should be queried regularly since faulty commands from the controller to the instrument are recorded there as well.

## B Telnet program examples

The following program example shows a simple `TcpClient` class that is intended to explain on how to get started with programming of sockets.

The example sets up a socket communication to R&S SGS and opens a simple user interface, very similar to the telnet, which allows input of commands. To enable real automation, further development of the program is required.

### TcpClient.h

```
#include <string>
//defines structs for socket handling
#include <netinet/in.h>
using namespace std;
typedef struct sockaddr_in SockAddrStruct;
typedef struct hostent      HostInfoStruct;
class TcpClient
{
public:
    TcpClient();
    ~TcpClient();
    void connectToServer( string &hostname, int port );
    void disconnect( );
    void transmit( string &txString );
    void receive( string &rxString );
    string getCurrentHostName( ) const;
    int    getCurrentPort( ) const;
private:
    string      currentHostName;
    int        currentPort;
    int        currentSocketDescr;
    SockAddrStruct serverAddress;
    HostInfoStruct * currentHostInfo;
    bool       clientIsConnected;
    int        receiveBufferSize;
};
```

### TcpClient.cpp

```
#include <string>
//defines structs for socket handling
#include <netinet/in.h>
using namespace std;
typedef struct sockaddr_in SockAddrStruct;
typedef struct hostent      HostInfoStruct;
class TcpClient
{
public:
    TcpClient();
```

```

~TcpClient();
void connectToServer( string &hostname, int port );
void disconnect( );
void transmit( string &txString );
void receive( string &rxString );
string getCurrentHostName( ) const;
int    getCurrentPort( ) const;
private:
    string      currentHostName;
    int         currentPort;
    int         currentSocketDescr;
    SockAddrStruct  serverAddress;
    HostInfoStruct * currentHostInfo;
    bool        clientIsConnected;
    int         receiveBufferSize;
};

#include <netdb.h>
#include <netinet/in.h>
#include <unistd.h>
#include "TcpClient.h"
TcpClient::TcpClient()
: currentHostName( "" )
, currentPort( 0 )
, currentSocketDescr( 0 )
, serverAddress ( )
, currentHostInfo( NULL )
, clientIsConnected( false )
, receiveBufferSize( 1024 )
{
}
TcpClient::~TcpClient()
{
    currentHostInfo = NULL;
}

void TcpClient::connectToServer( string &hostname, int port )
{
    currentHostInfo = gethostbyname( hostname.c_str( ) );
    if( currentHostInfo == NULL )
    {
        currentHostName = "";
        currentPort      = 0;
        currentHostInfo  = NULL;
        clientIsConnected = false;
        printf("error connecting host\n" );
    }
    currentHostName = hostname;
    currentPort      = port;
    currentSocketDescr = socket(AF_INET, SOCK_STREAM, 0);

```

```

if( currentSocketDescr == 0 )
{
    currentHostName    = "";
    currentPort        = 0;
    currentHostInfo    = NULL;
    clientIsConnected = false;
    printf("can't create socket\n" );
}
serverAddress.sin_family = currentHostInfo->h_addrtype;
serverAddress.sin_port   = htons( currentPort );
memcpy( (char *) &serverAddress.sin_addr.s_addr,
currentHostInfo->h_addr_list[0], currentHostInfo->h_length );
if( connect( currentSocketDescr, ( struct sockaddr *) &serverAddress,
sizeof( serverAddress ) ) < 0 )
{
    throw string("can't connect server\n" );
}
clientIsConnected = true;
}
void TcpClient::disconnect( )
{
    if( clientIsConnected )
    {
        close( currentSocketDescr );
    }
    currentSocketDescr = 0;
    currentHostName    = "";
    currentPort        = 0;
    currentHostInfo    = NULL;
    clientIsConnected = false;
}
void TcpClient::transmit( string &txString )
{
    if( !clientIsConnected )
    {
        throw string("connection must be established before any data can be sent\n");
    }
    char * transmitBuffer = new char[txString.length() +1];
    memcpy( transmitBuffer, txString.c_str(), txString.length() );
    transmitBuffer[txString.length()] = '\n'; //newline is needed!
    if( send( currentSocketDescr, transmitBuffer, txString.length() + 1, 0 ) < 0 )
    {
        throw string("can't transmit data\n");
    }
    delete [] transmitBuffer;
}
void TcpClient::receive( string &rxString )
{
    if( !clientIsConnected )
    {

```

```

    throw string("connection must be established before any data can be received\n");
}
char * receiveBuffer = new char[receiveBufferSize];
memset( receiveBuffer, 0, receiveBufferSize );
bool receiving = true;
while( receiving )
{
    int receivedByteCount = recv( currentSocketDescr,
    receiveBuffer, receiveBufferSize, 0 );
    if( receivedByteCount < 0 )
    {
        throw string("error while receiving data\n");
    }
    rxString += string( receiveBuffer );
    receiving = ( receivedByteCount == receiveBufferSize );
}
delete [] receiveBuffer;
}
string TcpClient::getCurrentHostName( ) const
{
    return currentHostName;
}
int TcpClient::getCurrentPort( ) const
{
    return currentPort;
}

```

### TelnetClient.cpp

```

#include <iostream>
#include "TcpClient.h"
void printUsage()
{
    cout<<"usage: EthernetRawCommand <server-ip> [scpi-command]"<<endl;
}
int main( int argc, char *argv[] )
{
    int errorCode          = 0; //no error
    bool useSingleCommand = false;
    string singleCommand   = "";
    string hostname        = "";
    int port                = 5025;
    string input            = "";
    TcpClient client;
    switch( argc )
    {
        case 3:
            useSingleCommand = true;
            singleCommand     = argv[2];
        case 2:
    }
}

```

```

        hostname      = argv[1];
        break;
    default:
        printUsage();
        return(-1);
    }
    try
    {
        client.connectToServer( hostname, port );
        bool terminate = false;
        while( !terminate )
        {
            char buffer[1024];
            if( useSingleCommand )
            {
                input = singleCommand; //send string
            }
            else
            {
                cin.getline( buffer, 1024 );
                input = buffer;
                if( input == "end" )
                {
                    terminate = true;
                }
            }
            if( !terminate)
            {
                client.transmit( input ); //send string
                int qPos = input.find( "?", 0 );
                //receive string only when needed
                if( qPos > 0 )
                {
                    string rcStr = "";
                    client.receive( rcStr );
                    cout << rcStr << endl;
                }
            }
            if( useSingleCommand )
            {
                terminate = true;
            }
        }
    }catch( const string errorString )
    {
        cout<<errorString<<endl;
    }
    client.disconnect( );
    return errorCode;
}

```

# Index

## Symbols

*OPC .....	301
*OPC? .....	301
*RST .....	310
*WAI .....	301
/var directory .....	213
9.91E37	
Remote control .....	300
180 - Adjustment failed .....	289
182 - Adjustment data missing .....	289
183 - Adjustment data invalid .....	289
200 - Cannot access hardware .....	289
201 - Hardware revision out of date .....	289
202 - Cannot access the EEPROM .....	289
203 - Invalid EEPROM data .....	289
204 - Driver initialization failed .....	289
241 - No current list .....	289
242 - Unknown list type specified .....	289
460 - Cannot open file .....	289
461 - Cannot write file .....	289
462 - Cannot read file .....	289
463 - Filename missing .....	289
464 - Invalid filename extension .....	289
465 - File contains invalid data .....	290
468 - Cannot find directory .....	290
469 - No files found .....	290

## A

AC supply .....	19, 35
Accept	
Security settings .....	138
Active adjustment data .....	86
Adjust all .....	129
Adjust I/Q modulator .....	129
Adjust level .....	129
Adjust synthesis .....	129
Adjustment active .....	87
Adjustment frequency .....	87
Advanced configuration	
LXI .....	182
Aperture time	
Power sensors .....	112
Application cards .....	15
Application notes .....	15
Apply network settings .....	141
AttFixed .....	287
Auto once	
Power sensors .....	111
Power viewer .....	111
Average level	
Power viewer .....	109

## B

Baseband bypass mode .....	151
Block data .....	297
Boolean parameters .....	297
Brackets .....	298
Brochures .....	14

## C

Case-sensitivity	
SCPI .....	294
Change password .....	137
Cleaning .....	285
Clear status	
Remote .....	200
Colon .....	298
Column separator Import/Export - user correction data ....	97
Comma .....	298
Command sequence	
recommendation .....	310
Remote .....	203
Commands .....	291
Brackets .....	298
Colon .....	298
Comma .....	298
Command line structure .....	299
Common .....	291
Double dagger .....	298
Instrument control .....	291
Overlapping .....	301
Question mark .....	298
Quotation mark .....	298
SCPI confirmed .....	291
Sequential .....	301
Syntax elements .....	298
Vertical stroke .....	298
White space .....	298
Common commands	
Syntax .....	293
Computer name .....	140
Changing .....	158
CONDITION .....	305
Confirm password .....	137
Connector	
I .....	34
LAN .....	34
LO IN .....	34
LO OUT .....	34
PCIe .....	33
Q .....	34
REF IN .....	34
REF OUT .....	34
RF OUT .....	34
TRIG .....	35
USB .....	33
Connector mode .....	116, 118
Connectors .....	33
Crest factor .....	66, 121
Current frequency .....	129

## D

Data sheets .....	14
Decimal point import/export - user correction data .....	97
DEF .....	296
Default instrument settings .....	21
Default values	
Remote .....	202
Delete instrument settings .....	219
Delta phase .....	82

- Delta temperature ..... 130
- Destination import/export
  - User correction data ..... 98
- Detector sensitivity
  - ALC ..... 93
- Device identify ..... 58, 142
- Device-specific commands ..... 291
- DHCP ..... 26
- Displaying
  - All messages ..... 73
- Documentation overview ..... 13
- Double dagger ..... 298
- Double pulse delay
  - PULM ..... 116
- DOWN ..... 296
- E**
- Eco mode
  - Activating ..... 143
- Edit User Correction Data ..... 95
- Electrostatic discharge ..... 16
- EMI suppression ..... 17
- ENABLE ..... 305
- Enable registers
  - Remote ..... 201
- Error
  - Key ..... 32
- Error message
  - Query interrupted ..... 187
  - Resource locked ..... 187
- Error messages ..... 287
  - Adjustment data invalid (183) ..... 289
  - Adjustment data missing (182) ..... 289
  - Adjustment failed (180) ..... 289
  - Cannot access hardware (200) ..... 289
  - Cannot access the EEPROM (202) ..... 289
  - Cannot open file (460) ..... 289
  - Cannot read file (462) ..... 289
  - Cannot write file (461) ..... 289
  - Driver initialization failed (204) ..... 289
  - Driver invalid EEPROM data (203) ..... 289
  - File cannot find directory (468) ..... 290
  - File contains invalid data (465) ..... 290
  - Filename missing (463) ..... 289
  - Hardware revision out of date (201) ..... 289
  - Invalid filename extension (464) ..... 289
  - No current list (241) ..... 289
  - No files found (469) ..... 290
  - SCPI ..... 288
  - Unknown list type specified (242) ..... 289
- Error messages - display list ..... 268
- Error queue ..... 306
- Error queue query ..... 267, 268
- Error queues
  - recommendations ..... 311
- ESD ..... 16
- ESE (event status enable register) ..... 307
- ESR ..... 303
- ESR (event status register) ..... 307
- EVENT ..... 305
- Event status enable register (ESE) ..... 307
  - Remote ..... 200
- Event status register (ESR) ..... 307
  - Remote ..... 200
- Expiration date of option ..... 133
- Ext. trigger
  - Gate polarity ..... 117
  - Input slope ..... 117
- Extension import/export - user correction data ..... 97
- Extension mode
  - Higher frequency ..... 149
- External controller ..... 22
- External devices ..... 22
- External impedance
  - Pulse modulation ..... 114
- External reference
  - Connector ..... 32, 34
  - Input frequency ..... 85
- F**
- Factory preset ..... 143
- Factory recovery
  - See service manual ..... 160
- Fast settings ..... 173, 177
- File list ..... 216
- Fill table range ..... 99
- Fill with sensor list files ..... 99
- Filter
  - Power sensors ..... 110
- Filter length
  - Auto ..... 111
  - User-defiend ..... 111
- Firmware update
  - Select package ..... 138
  - Several instruments ..... 159
  - Update all ..... 138
- Firmware version ..... 133
- Floating licenses ..... 133
- Frequency
  - At the RF output ..... 81
  - Incl. RF offset ..... 66
  - Limit to 6GHz ..... 143
  - Offset ..... 81
  - Power sensors ..... 110
  - Without RF offset ..... 81
- Frequency range extension ..... 149
- Full range ..... 130
- Function check ..... 21
- G**
- Gain
  - impairment ..... 119
- Gain imbalance ..... 119
- Gate input polarity ..... 117
- Gateway ..... 141
- Getting started ..... 13
- GPIB ..... 162
  - Characteristics ..... 170
- H**
- Hardware
  - Requirements ..... 23
- Hardware options ..... 132
- Help ..... 13
- HiSLIP ..... 162
  - Protocol ..... 167
  - Resource string ..... 166
- History ..... 73, 74

Hostname ..... 140  
     Changing ..... 158  
     Default ..... 71  
 Hostname prefix ..... 57

**I**

I / Q

- Connectors ..... 34
- I offset ..... 120
- I/Q impairments ..... 118
- I/Q modulation ..... 66, 121, 147
  - Crest factor ..... 121
- I/Q wideband ..... 121

ID

- Key ..... 32

Identification

- Remote ..... 200

Imbalance ..... 122

Impairment ..... 118

Import/Export

- User correction data ..... 97, 98

INF ..... 296

Input

- Pulse polarity ..... 114

Input connector ..... 34

Input slope

- External trigger ..... 117

Input/Output connector ..... 35

Install FW ..... 159

Install SW-Option ..... 133

Installed assembly ..... 131

Installing

- Hardware ..... 23
- R&S SGMA-GUI ..... 23
- Requirements ..... 23
- Software ..... 23
- Uninstalling the old version ..... 23
- Update ..... 23

Instrument help ..... 13

Instrument messages ..... 291

Instrument Name ..... 66

Instrument security procedures ..... 14

Instrument settings

- Recall ..... 202, 219
- Save ..... 202, 221

Interface messages ..... 291, 292

Interfaces

- GPIO ..... 170
- USB ..... 168

Interrupt ..... 308

Invalid results

- Remote control ..... 300

IP address ..... 141, 166

- Changing ..... 26

IP Address ..... 66

IP address mode ..... 140

IP configuration

- LXI ..... 182

IST ..... 303

IST flag

- Remote ..... 200

**K**

Key
 

- ID ..... 32
- LAN ..... 32
- POWER ON ..... 31
- POWER ON/STANDBY ..... 31
- RF ON ..... 31

Keywords

- see Mnemonics ..... 292

**L**

LAN
 

- Configuration ..... 24
- Connector ..... 34
- Interface ..... 165
- IP address ..... 166
- Key ..... 32
- Reset ..... 180
- VXI protocol ..... 168

LAN configuration

- LXI ..... 181

LAN connection

- Reset address mode ..... 141

LED

- ERROR / WARNING ..... 32
- REF EXT ..... 32

Level

- RF output ..... 66, 88

Level limit ..... 90

Level offset ..... 66, 88

- Power sensors ..... 110
- State (power sensors) ..... 110

Level range

- RF output ..... 89

License for software option ..... 133

Linux ..... 22

LO

- Connector ..... 34
- Coupling source ..... 153

LO coupling

- Setup ..... 154

Load instrument settings ..... 202, 219

Loaded modules ..... 133

Local oscillator ..... 82

- Coupling source ..... 153
- Source ..... 83

Lost LAN connection to an instrument ..... 141

LXI

- Advanced configuration ..... 182
- configuration ..... 179
- IP configuration ..... 182
- LAN configuration ..... 181
- Ping ..... 183
- Remote trace (SCPI) ..... 184
- Reset (LCI) ..... 180

**M**

Maintenance
 

- Accept ..... 139
- Operation ..... 138

Malfunctions

- reacting ..... 311

MAX ..... 296

- Message ..... 62
  - Additional information ..... 73
  - All messages ..... 74
  - Brief ..... 73
  - Deleting ..... 73
  - Deleting all ..... 73
  - Deleting brief ..... 73
  - Displaying ..... 73
  - Error ..... 73
- Message level ..... 62
- Messages
  - Commands ..... 291
  - Instrument ..... 291
  - Instrument responses ..... 292
  - Interface ..... 291
- MIMO
  - Connector ..... 34
- MIN ..... 296
- Mnemonics ..... 292
  - Optional ..... 294
- Mode
  - PULM ..... 115
  - Pulse modulation ..... 115
  - RF level ..... 89
  - TRIG connector ..... 116, 118
  - User correction data ..... 97
- Mode IP address ..... 140
- Monitoring
  - Collisions ..... 187
  - Same remote channel ..... 187
- N**
- NAN ..... 296
- NAN (not a number)
  - Remote control ..... 300
- Network settings ..... 139
- New instrument
  - Scan ..... 69
  - Search ..... 69
- New password ..... 137
- NINF ..... 296
- Noise ratio
  - Power sensors ..... 111
- NRP power viewer
  - Settings ..... 107
  - Use S-Parameter ..... 112
- NRP sensor mapping
  - Connector ..... 104
  - Protocol ..... 104
  - Scan ..... 105
  - Sensor name ..... 104
  - Settings ..... 104
- NTRansition ..... 305
- Number of licenses ..... 133
- Numeric parameters ..... 295
- Numeric values
  - Special ..... 296
- O**
- Offset ..... 88, 122
  - Frequency ..... 81
- Old password ..... 136, 137
- Open source acknowledgment ..... 14
- Open source acknowledgments ..... 60, 133
- Operating system ..... 22
- Operation complete
  - Remote ..... 201
- Operation mode ..... 80
- Option
  - Hardware ..... 132
  - Software ..... 132
- Option key ..... 133
- Options
  - Identification (remote) ..... 201
- OSA ..... 14
- Output connector ..... 34
- Output frequency ..... 86
- Output queue ..... 303
- Overlapping commands ..... 301
  - Preventing ..... 301
- P**
- Packing ..... 286
- Parallel poll register enable
  - Remote ..... 201
- Parameters
  - Block data ..... 297
  - Boolean ..... 297
  - Numeric values ..... 295
  - SCPI ..... 295
  - Special numeric values ..... 296
  - String ..... 297
  - Text ..... 297
- PCIe
  - Connecting ..... 28
  - Connector ..... 33
- PCIe interface mode ..... 139
- PEP ..... 66
- Period
  - PULM ..... 115
- Phase coherence
  - Setup ..... 154
- Ping
  - LXI ..... 183
- Polarity
  - Pulse modulation ..... 114
- Power On
  - Key ..... 31
- Power sensors
  - Activation ..... 109
  - Aperture time ..... 112
  - Auto once ..... 111
  - Filter ..... 110
  - Filter length ..... 111
  - Frequency ..... 110
  - Level (average) ..... 109
  - Level (peak) ..... 109
  - Level offset ..... 110
  - Noise ratio ..... 111
  - Serial number ..... 109
  - Source ..... 110
  - State ..... 109
  - State (level offset) ..... 110
  - Timeout ..... 111
  - Unit ..... 109
  - Update ..... 107
  - Use default aperture time ..... 111
  - Zero ..... 109
- Power switch ..... 20, 35
- Power viewer
  - Auto once ..... 111

- PPE ..... 303
- Preset instrument settings ..... 21, 123
- Protection ..... 60, 134
- Protocol
  - VXI ..... 168
- Ptransition ..... 305
- PULM
  - Delay ..... 116
  - Double pulse width ..... 115
  - Mode ..... 115
  - Period ..... 115
- Pulse
  - Length ..... 115
  - Width ..... 115
- Pulse generator
  - Pulse delay ..... 116
  - Width ..... 115
- Pulse modulation
  - Double pulse delay ..... 116
  - Double pulse width ..... 115
  - Mode ..... 115
  - Period ..... 115
  - Repetition frequency ..... 115
- Q**
- Q offset ..... 120
- Quadrature offset ..... 120, 123
- Queries ..... 291, 300
  - Status ..... 309
- Question mark ..... 298, 300
- Questionable status register ..... 307, 308
- Quotation mark ..... 298
- R**
- Rack mounting ..... 19
- Readjust ..... 90
- Ready state ..... 20
- Recall instrument settings ..... 202, 219
- Recall intermediate ..... 202
- Recommendations
  - remote control programming ..... 310
- Reducing power consumption ..... 143
- REF
  - Connector ..... 34
- REF EXT
  - Key ..... 32
- REF/LO OUT connector ..... 154
- Reference frequency adjustment mode ..... 87
- Reference oscillator ..... 84
- Registers ..... 303
- Release notes ..... 14
- Remote control
  - Basics ..... 291
  - Connect ..... 162
  - Programming examples ..... 191
- Remote trace
  - LXI ..... 184
- Rename
  - File ..... 220
- Reset delta phase display ..... 82
- Reset instrument settings ..... 21
- Reset values
  - Remote ..... 202
- Resource string
  - VISA ..... 166
- Resource strings ..... 142
- Restart ..... 156
- Restart network ..... 140
- RF frequency ..... 81
- RF level ..... 87
  - Mode ..... 89
- RF ON
  - Key ..... 31
- RF OUT
  - Connector ..... 34
- RF output level ..... 66, 88
- S**
- S-Parameter
  - Activate corrections ..... 112
- Safety instructions ..... 14
- Save instrument settings ..... 202, 221
- Save intermediate ..... 202
- Scan
  - NRP sensor mapping ..... 105
- SCPI
  - Error messages ..... 288
  - Parameters ..... 295
  - Syntax ..... 293
  - Version ..... 163
- SCPI confirmed commands ..... 291
- SCPI disabled ..... 24
- SCPI remote trace
  - LXI ..... 184
- Searching a new instrument ..... 69
- Security password ..... 138, 139
- Security settings
  - Accept ..... 138
  - Change password ..... 137
  - Confirm password ..... 137
  - LAN connection ..... 137
  - New password ..... 137
  - Old password ..... 136, 137
  - Security password ..... 138, 139
  - USB device ..... 137
  - User name ..... 136
- Select ASCII destination
  - User correction data ..... 98
- Select ASCII source
  - User correction data ..... 98
- Self-test
  - Remote ..... 203
- Selftest ..... 145
- Sequential commands ..... 301
- Serial number
  - Power sensors ..... 109
- Service manual ..... 14
- Service request (SRQ) ..... 306, 308
- Service request enable register (SRE) ..... 306
  - Remote ..... 202
- Setting commands ..... 291
- Settings
  - NRP power viewer ..... 107
  - NRP sensor mapping ..... 104
- Shutting down ..... 20
- Socket ..... 162
- Software
  - Requirements ..... 23
  - VISA driver ..... 23
- Software options ..... 132

- Source  
  Local oscillator ..... 83  
  Power sensors ..... 110  
  Pulse modulation ..... 114  
  Reference oscillator ..... 67, 85
- Source import/export  
  User correction data ..... 98
- SRE ..... 303  
SRE (service request enable register) ..... 306  
SRQ (service request) ..... 306, 308  
Standby ..... 20, 156  
  Key ..... 31
- State  
  ALC ..... 93  
  I/Q modulation ..... 66, 121  
  Impairments ..... 122  
  Power sensors ..... 109  
  Pulse modulation ..... 114  
  User correction ..... 94
- Static IP address  
  Lost connection ..... 141
- Status  
  Queries ..... 309
- Status byte  
  Remote ..... 200, 202
- Status byte (STB) ..... 306
- Status messages  
  AttFixed ..... 287
- Status registers ..... 303  
  CONDition ..... 305  
  ENABLE ..... 305  
  EVENT ..... 305  
  model ..... 304  
  NTRansition ..... 305  
  parts ..... 304  
  PTRansition ..... 305
- Status reporting system ..... 302  
  Application ..... 308  
  Common commands ..... 199
- STB ..... 303
- Storing ..... 286
- String in remote commands ..... 297
- Subnet mask ..... 141
- Suffixes ..... 294
- Synchronization bandwidth ..... 85
- Syntax elements  
  SCPI ..... 298
- System directory ..... 213
- T**
- Telnet ..... 162
- Text paramters in remote commands ..... 297
- Timeout  
  Filter (power sensors) ..... 111
- TRIG connector  
  Signal ..... 116, 118
- Trigger  
  Connector ..... 35  
  Event (remote) ..... 203
- Trigger connector mode ..... 116, 118
- Trigger mode  
  Pulse modulation ..... 117
- U**
- UCOR  
  Fill with sensor ..... 100
- UP ..... 296
- Update package  
  Error ..... 160
- Updating R&S SGMA-GUI ..... 23
- USB  
  Connecting ..... 28  
  Connector ..... 33  
  Interfaces ..... 168
- USB device ..... 137
- USB install  
  See service manual ..... 160
- Use default aperture time  
  Power sensors ..... 111
- User correction  
  State ..... 94  
  Value ..... 94
- User correction data ..... 95  
  Mode ..... 97
- User manual ..... 13
- User name ..... 136
- V**
- Value  
  User correction ..... 94
- Vertical stroke ..... 298
- VISA ..... 162  
  HiSLIP string ..... 142  
  LAN string ..... 142  
  PCIe string ..... 142  
  Resource string ..... 166  
  Serial string ..... 142  
  USB string ..... 142
- VXI protocol ..... 168
- VXI-11 ..... 162
- W**
- Wait  
  Remote ..... 203
- Warnings ..... 287
- White papers ..... 15
- White space ..... 298
- Z**
- Zero  
  Power Sensors ..... 109
- Zeroconf (APIA) protocol ..... 26