

Mako G

G-507



- Sony IMX264 CMOS sensor
- Power over Ethernet
- 5.1 megapixel resolution
- Ultra-compact design

Description

GigE Vision camera with Sony IMX264 CMOS sensor, Pregius global shutter

Mako G-507B/G-507C is an industrial GigE camera with the Sony IMX264 CMOS sensor. Mako G cameras have an ultra-compact form factor and the same mounting positions as many analog cameras. All models include Power over Ethernet (PoE), three opto-isolated outputs, and a 64 MByte image buffer. The image quality profits from the precisely aligned sensor.

Options:

- Various optical filter and lens mount options
- White medical housing

See the [Modular Concept](#) for lens mount, optical filter, and case design options.

Specifications

Mako G	G-507
Interface	IEEE 802.3 1000BASE-T, IEEE 802.3af (PoE)
Resolution	2464 (H) × 2056 (V)
Sensor	Sony IMX264
Sensor type	CMOS
Cell size	3.45 μm x 3.45 μm
Lens mount	C-Mount
Max frame rate at full resolution	23.7 fps
ADC	12 bit
Image buffer (RAM)	64 MByte
Output	

Mako G	G-507
Bit depth	12 bit
Mono modes	Mono8, Mono12, Mono12Packed
Color modes YUV	YUV411Packed, YUV422Packed, YUV444Packed
Color modes RGB	RGB8Packed, BGR8Packed
Raw modes	BayerRG8, BayerRG12, BayerRG12Packed
General purpose inputs/outputs (GPIOs)	
Opto-isolated I/Os	1 input, 3 outputs
Operating conditions/dimensions	
Operating temperature	+5 °C to +45 °C housing temperature
Power requirements (DC)	12 to 24 VDC; PoE
Power consumption (@12 V)	2.4 W @ 12 VDC; 2.8 W PoE
Mass	80 g
Body dimensions (L × W × H in mm)	60.5 × 29 × 29 (including connectors)
Regulations	CE, RoHS, REACH, WEEE, FCC, ICES

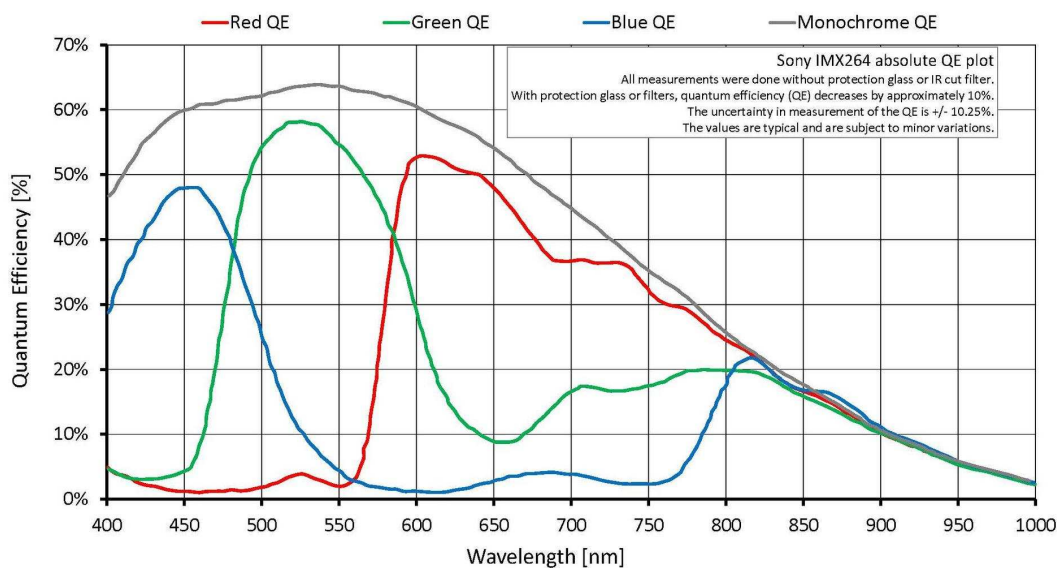

Features

Image optimization features:

- Auto gain (manual gain control: 0 to 40 dB; 0.1 dB increments)
- Auto exposure (52 μ s to 85.9 s; 19.5 μ s increments)
- Auto white balance (color models only)
- Binning



- Color transformation, hue, saturation (color models only)
- Decimation
- Gamma correction
- Look-up table (LUT) (1)
- Region of interest (ROI), separate ROI for auto features

Camera control features:

- Event channel
- Image chunk data
- Storable user sets
- StreamBytesPerSecond (easy bandwidth control)
- Stream hold
- Sync out modes: Trigger ready, input, exposing, readout, imaging, strobe, GPO
- Temperature monitoring (main board)

Technical drawing

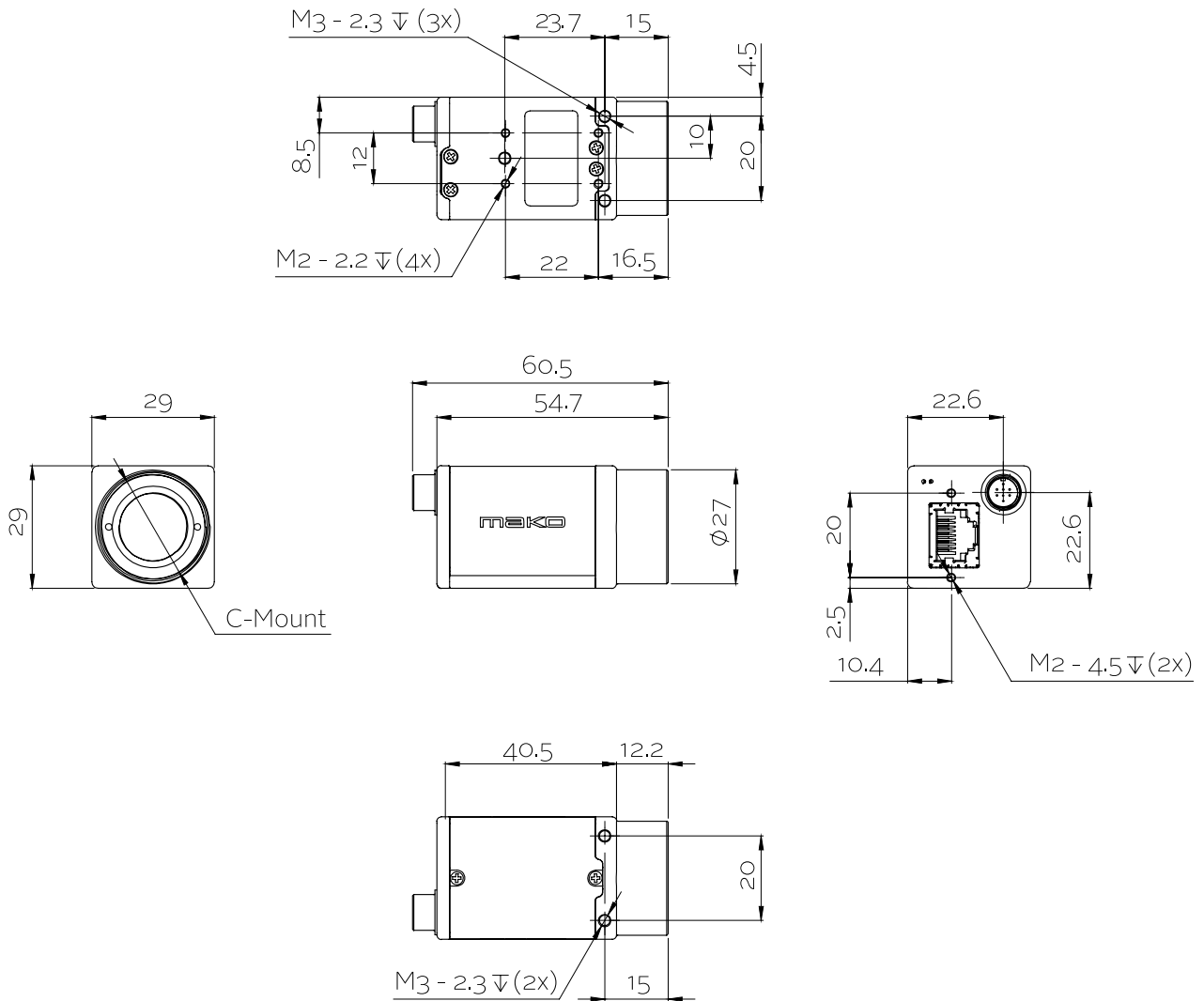



Applications

Mako G-507B/G-507C is suitable for a wide range of applications including:

- Robotics
- Quality control
- Inspection, surveillance
- Industrial imaging
- Machine vision
- Logistics